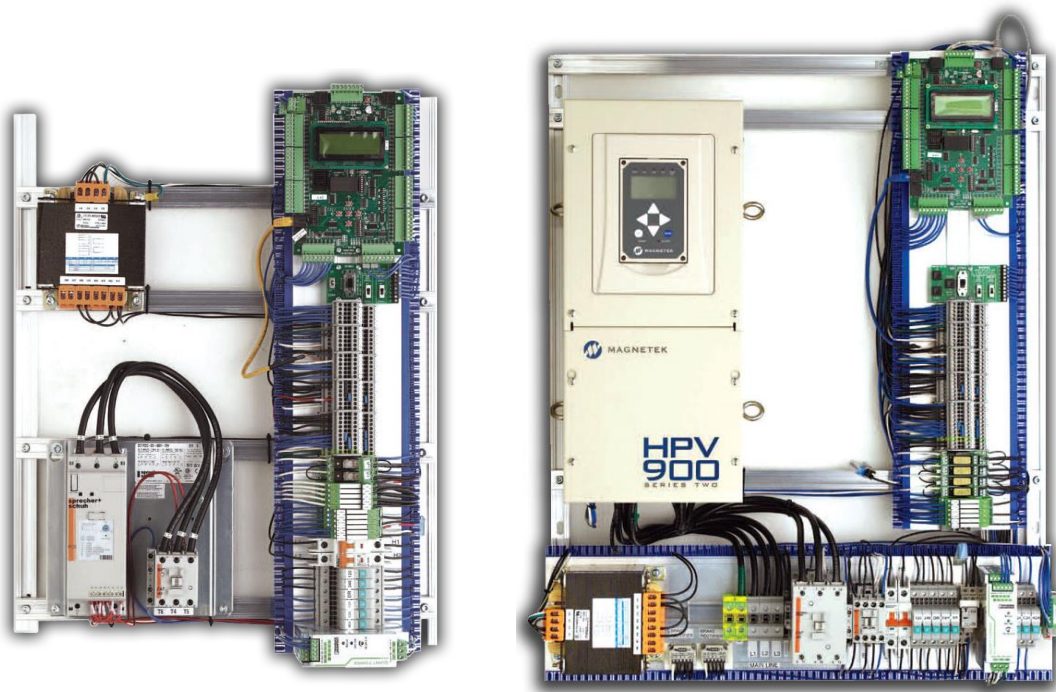




# SMARTRISE

## EQUIPMENT INSTALLATION MANUAL

Hydraulic Controllers  
AC Traction Controllers



Version 3.20

*This manual contains information for software version 3*



# SMARTRISE UNIVERSITY

Smartrise Engineering offers several options for customer training:

- 30 Minute phone introductory training for new customers
- 4 or 8 hour personal training classes at customer's office or jobsite
- 4 hour regional training classes held throughout the U.S.A. & Canada
- Online training videos to supplement regional training courses

To accommodate the busy work schedules of our customers all regional training classes are 4–hours each and are held in one day from 8am to 5pm.

Training classes can also be performed at the customer's site in place of the universal 4 or 8-hour training.

Smartrise Training is recognized by the NAEC for CET credits for up to 8 hours.

For more information, contact the main office at (916) 457-5129 or send an email to: [Training@smartrise.us](mailto:Training@smartrise.us)

# WARRANTY

---

Products sold by Smartrise Engineering (Smartrise) are warranted to be free from defects in workmanship and material for a period of fifteen (15) months from the date of shipment. Any products defective in workmanship or material shall, at the discretion of Smartrise, be repaired or replaced at no charge to the Buyer. Determination as to whether a product is defective and eligible for an authorized return rests with Smartrise. The obligation of Smartrise shall be limited solely to that of repairing or replacing of defective products returned to Smartrise by the Buyer. It is the obligation of the Buyer to return defective products to Smartrise with all parts and documentation. A return merchandise authorization (RMA) number must be obtained from Smartrise prior to returning products.

Smartrise makes no warranty as to the fitness of its products for any application not specified in writing by Smartrise. Use of Smartrise products in any unauthorized manner will void this warranty and may cause damage to the product and/or injury.

This warranty is exclusive and in lieu of all other warranties, expressed or implied, including, but not limited to, any warranty of merchantability or of fitness for a particular purpose and therefore, the Buyer hereby waives any and all claims.

# LIMITATIONS OF LIABILITY

---

In no event shall Smartrise Engineering be liable for loss of profit, indirect, consequential, or incidental damages whether arising out of warranty, breach of contract or tort. Failure to understand the elevator control system could result in damage to the system and possibly even danger to the passengers. Only properly trained and qualified personnel should attempt to work on the system.

# CODE COMPLIANCE

---

Smartrise controllers are certified by ASME A17/CSA B44 and the State of California. Depending on the jurisdiction where the controller is operating, it will be configured per the specific local code requirements as specified by the buyer.

# PERSONAL SAFETY: PERSONAL INJURY AND/OR DEATH MAY OCCUR

---

Smartrise Engineering controllers should only be installed by qualified, licensed, trained elevator personnel familiar with the operation of microprocessor-based elevator controls. All safety devices, known as electronic protective devices (limits, governors, hoistway locks, car gate, etc.) shall be tested to be fully functional prior to attempting to run the elevator. Never operate the system with any safety device rendered inoperative in any way. The User is responsible for compliance with the current National Electrical Code with respect to the overall installation of the equipment, and proper sizing of electrical conductors connected to the controls. The User is responsible for understanding and applying all current Local, State, Provincial, and Federal Codes which govern practices such as controller placement, applicability, wiring protection, disconnections, over current protection, and grounding procedures. To prevent the risk of personal shock, all equipment should be securely grounded to earth ground as outlined in the National Electrical Code. Failure to obtain an actual earth ground source may result in electrical shock to personnel.

## EQUIPMENT SAFETY

---

All equipment chassis should be securely grounded to earth ground as outlined in the National Electrical Code. Improper grounding is the most common cause of electrical component failures and electrically noise-induced problems. All component replacement must be done with the main line power off. Unauthorized modifications to circuits or components should not be attempted without Smartrise Engineering authorization to ensure all safety features are maintained. Care should be taken when using test leads and jumpers to avoid applying high voltage or ground to low voltage microprocessor circuits.



# CONTROLLER GROUNDING REQUIREMENTS

---

**NOTE – For the controller to function properly it is very important to provide proper building ground connections to the controller.**

- ❖ Examples of a proper building-to-controller ground connection is to attach the ground cable to:
  - The street side of the incoming water main.
  - To a grounding rod that has been driven into the pit flooring.
- ❖ The controller has a common ground bus terminal connection.



- ❖ All grounds need to land at this common point including building, motor, transformer, and filter grounds. This prevents ground loops, and will limit the impedance between the grounds and noise will be channeled back to building ground.

Providing a proper ground is mandatory and will improve the performance of the controller.

# TABLE OF CONTENTS

CONTROLLER GROUNDING REQUIREMENTS.....	4
GENERAL INFORMATION .....	9
Bypass Term Limits .....	19
HYDRO INSTALLATION .....	21
Main Power Setup.....	22
Motor Wiring – 3/9 Lead Motor Wiring.....	23
Motor Wiring – 6/12 Lead Motor Wiring.....	24
Valve Wiring.....	25
Soft Start setup – Sprecher + Schuh .....	26
Soft Start setup – Siemens .....	30
AC TRACTION INSTALLATION .....	36
Main Power Setup.....	37
Motor & Brake Wiring.....	38
Encoder Wiring (Instructions per Manufacturer Drive Type) .....	39
MAGNETEK HPV900-S2 DRIVE .....	44
INDUCTION MOTOR SETUP.....	44
PERMANENT MAGNET SETUP.....	49
KEB DRIVE.....	56
INDUCTION MOTOR SETUP.....	56
PM MOTOR SETUP .....	65
Brake Board Adjusting & Replacing Procedure.....	75
Brake Board Replacement .....	76
Brake Board Adjustment.....	77
Procedure On Swapping The Cedes Interface Board.....	81
STEEL TAPE LANDING SYSTEM .....	83
IP8300 SELECTOR, TAPE AND MAGNETS .....	84
DOOR ZONE MAGNET INSTALLATION – TAPE.....	87
TRACTION DZ1/DZ2 MAGNET PLACEMENT – ALL LANDINGS.....	88
HYDRO DZ1/DZ2 MAGNET PLACEMENT – TOP TERMINAL LANDING.....	89
HYDRO DZ1/DZ2 MAGNET PLACEMENT – INTERMEDIATE LANDINGS.....	90
HYDRO DZ1/DZ2 MAGNET PLACEMENT – BOTTOM TERMINAL LANDING.....	91
UT1/DT1 MAGNET DESCRIPTION – TAPE.....	92

UT1/DT1 MAGNET ALIGNMENT – TAPE .....	93
UET/DET MAGNET PLACEMENT – TAPE.....	94
HOISTWAY SWITCH POSITIONING TABLE – NTS .....	95
CEDES APS System .....	96
EMERGENCY TAPE BREAK SWITCH (OPTIONAL) .....	110
TAPELESS LANDING SYSTEM .....	118
GOVERNOR ENCODER LANDING SYSTEM INSTALLATION.....	122
UET/DET MAGNET PLACEMENT – RAIL.....	130
NTS MAGNET PLACEMENT – RAIL.....	131
SLIDE DISTANCE DETERMINATION PROCEDURE FOR ETS MAGNET PLACEMENT .....	132
MANUAL ETS and FINAL LIMIT SWITCHES .....	139
FINAL SWITCH PLACEMENT - TAPE .....	140
FINAL SWITCH PLACEMENT – RAIL .....	141
SMOKE SENSORS, SHUNT, & LOAD WEIGHING .....	142
Smoke Sensor Setup .....	143
SMOKE SENSOR SETUP ILLUSTRATION – LOWER LEVEL MACHINE ROOM.....	147
Shunt Operation.....	148
Load Weighing .....	149
EMERGENCY POWER & SAFETY STRING .....	150
Emergency Power .....	151
SAFETY STRING DESCRIPTION .....	152
SAFETY STRING TROUBLESHOOTING .....	152
DOOR OPERATOR GENERAL.....	153
INSTALLATION.....	153
MOVFR DOOR OPERATOR.....	154
MOVFR DOOR OPERATOR – G.A.L. CERTIFIED PHE.....	155
IPC DOOR OPERATOR CONTROL MODEL D3000.....	156
Adjusting Door Dwell Times.....	161
Battery Lowering Device .....	162
Smartrise Battery Lowering Device – “BLD” .....	163
Reynolds & Reynolds Battery Lowering Device – “BLD” .....	168
BLD / MOVFR Door Operator Voltage Issues.....	170
Learning the Hoistway .....	171
Adjusting Car Speeds .....	175
Car Speed Profiles Overview.....	176

Adjusting Floor Levels .....	180
Adjustment Too High/Too Low method .....	181
Adjusting up/down Stop Points method.....	183
Testing Procedures for Hydro Controllers .....	186
Emergency Power Testing.....	187
Normal Limit Testing Setup.....	188
Normal / NTS Stopping test .....	189
ETS Slowdown Test .....	190
Normal/Directional limits Test.....	191
Re-leveling with In-Car Stop switch (Hydraulic System): .....	191
Redundancy test .....	192
Battery Lowering Test .....	192
Buffer Test (IP8300 Landing System) .....	193
Buffer Test (CEDES APS Landing System) .....	194
Stop Ring Test – Low Speed .....	195
Low Oil / Low Pressure Test .....	196
Leveling Speed Test (v2.35e or newer only) .....	196
Leveling Zone Test.....	197
Pressure Test (Hydraulic System): .....	198
Hydro Rupture setup.....	198
Testing Procedures for Traction Controllers.....	199
Normal Limit Testing Setup.....	200
Normal / NTS Stopping test .....	201
ETS Slowdown Test .....	202
NORMAL/DIRECTIONAL LIMITS.....	203
REDUNDANCY TEST .....	204
MANUAL BRAKE RELEASE TEST .....	204
BATTERY LOWERING TEST .....	204
Buffer Test/counterweight test (IP8300 LANDING SYSTEM) .....	205
Buffer Test/counterweight test (CEDES APS Landing System) .....	206
PRESSURE TEST (HYDRAULIC SYSTEM): .....	208
RE-LEVELING WITH IN-CAR STOP SWITCH (HYDRAULIC SYSTEM): .....	208
STOP RING TEST – LOW SPEED .....	209
OVERSPEED AND GOVERNOR TEST – MAGNETEK DRIVE .....	210
EARTHQUAKE COUNTERWEIGHT TEST .....	211

LEVELING ZONE TEST .....	212
UNINTENDED MOVEMENT .....	212
RACK AND PINION DROP TEST .....	213
Loss of Traction Test (2010 code compliance only).....	215
OTHER ADJUSTMENTS .....	217
ACCESS TOP/BOTTOM LIMITS:.....	217
POSITION INDICATOR VIA CE: .....	217
RESYNCHING - HYDROS.....	217
SIMPLEX PARKING SETUP.....	217
HYDRO RUPTURE SETUP .....	217
SMARTRISE MENU DEFINITIONS.....	218
FAULTS & ALARMS .....	226
Common Fault Clearing Procedures .....	229
ALARM DESCRIPTION INDEX.....	266
SRU INPUT / OUTPUT PROGRAMMING TUTORIAL.....	271
APPENDIX A – SMARTRISE BOARDS.....	274
APPENDIX B – MAKING CAT5 CABLES .....	276
APPENDIX C – REPLACING RELAYS .....	277
ADDENDUM I – REPLACING AND PROGRAMMING A DEFECTIVE SRU BOARD.....	280
ADDENDUM II – ENCODER WIRING TABLES .....	287
ADDENDUM III – TRACTION BRAKE PICK OPERATION .....	288
ADDENDUM IV – PARAMETER ADJUSTMENTS .....	289
ADDENDUM V – SECURITY.....	292
ADDENDUM VI – SCREEN LOCKOUT FEATURE.....	294
ADDENDUM VII – PI CONVERSION TABLE.....	295

# GENERAL INFORMATION

---

## THE JOB BINDER

The job binder is a 2.5” white binder that contains specific information about the job you are installing. The cover contains the job name and job number that is required for technical support with Smartrise Engineering. This binder should be kept at the jobsite at all times for future reference and troubleshooting.

## COMPONENTS

The following components are included in each job binder.

1. Software
  - a. The binder contains a 256meg USB flash drive that contains all the software, drawings and programs needed for each specific job.
2. Drawings or Prints
  - a. There are anywhere from 13 to 17 sheets of drawings that pertain to that specific controller. These prints include an index indicating the job specifics, tables that show correct dip switch settings, jumper settings for individual boards, and factory and field wiring diagrams and generic wiring references.
    - i. The solid lines on the prints show factory installed wiring.
    - ii. The dashed lines show installer wiring.
  - b. If the voltages or wiring for your job does not match the *Job Specification table* on the ‘Sheet 01: Getting Started’ page of the drawings, contact Smartrise Engineering for clarification **before** powering up.
3. Manual
  - a. The Equipment Installation Manual contains useful information for installation, testing, adjusting, troubleshooting, menu navigation and much more.

**For the most recent version of our installation manual go to [www.smartrise.us](http://www.smartrise.us), click on Support and download a pdf copy of our latest release.**
4. IO Sheets
  - a. All binders include an IO sheet that shows each board’s input & output programming. This is very useful when locating a specific IO for installation and/or troubleshooting and for recording changes in the SRU IOs.
5. Drive, Door Operator, and other operating manuals (optional)

## Common Installation Issues & Procedures

### CARTOP COMMUNICATION ISSUES

Make sure to connect the shield of the CN+/CN- shielded pair to reference (REF) on **both ends**. This communication cable part of the traveler located between the machine room and car top board. Make sure the CN+ & CN- wires are connected to the same terminals in the machine room as well as the cartop DIN rails.

**Special Note on 2-Board Systems** – Make sure the software on the COP SRU says “Prewire CT” and **NOT** “Prewire COP”. Prewire COP software **WILL NOT** communicate with the machine room SRU board.

### HALL BOARD COMMUNICATION TESTING

To test communication on any hall board turn on Dip Switch 8. The two green LEDs on the hall board blink indicating it is transmitting and receiving communication from the machine room. This is a test dip switch only. Do this one floor at a time when installing the hall boards; it will confirm that the wiring and board are good. Always do this before moving onto the next floor.

### JUMPING OUT UNUSED INPUTS

If the drawings show a normally closed contact for an Input your system does not require, apply a jumper from 24vdc to the specified Input terminal. All Smartrise boards **Receive 24vdc inputs ONLY** and provide **24vdc reference via programmed outputs**.

### Entering Car Calls

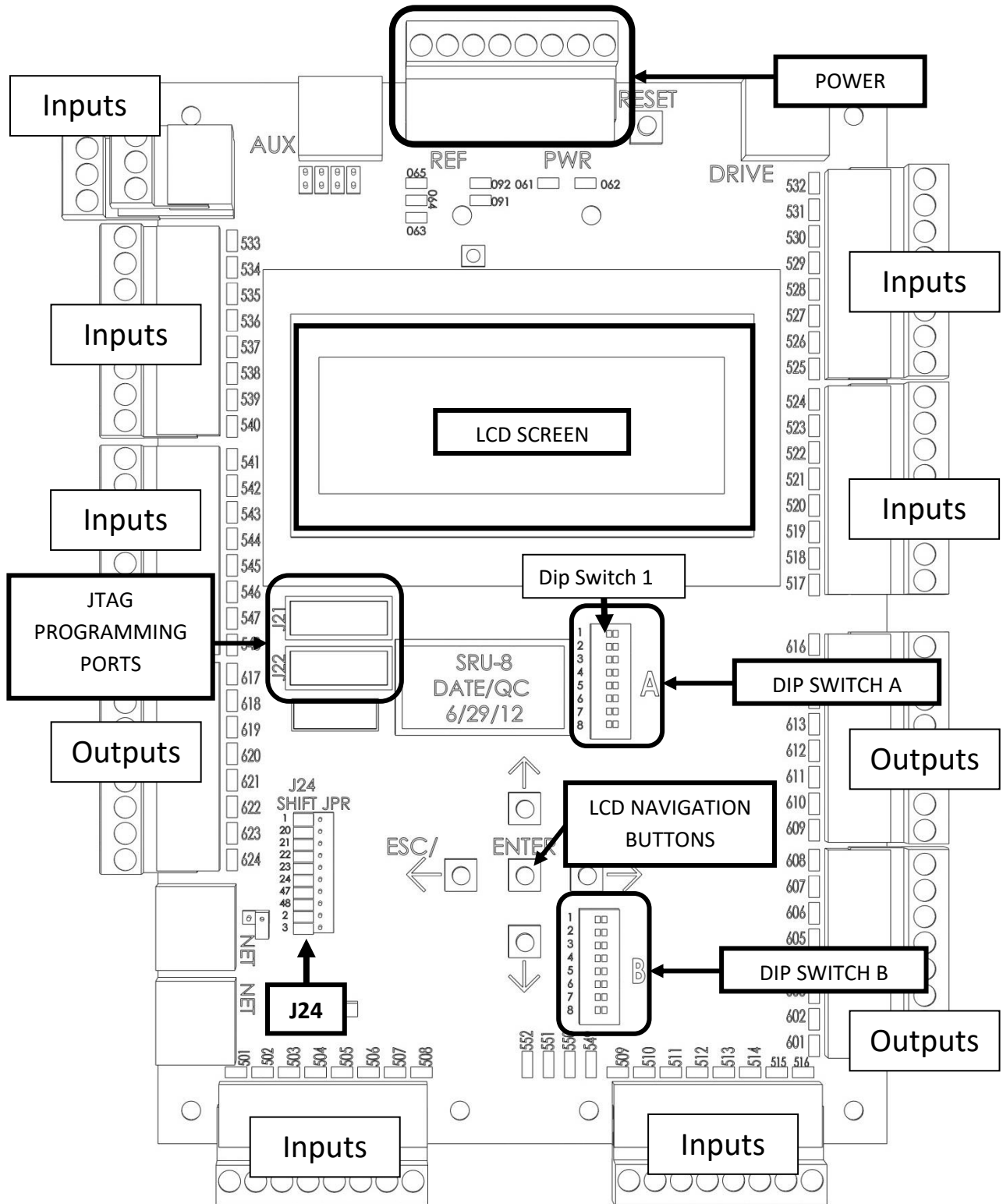
You can enter a car call from the Machine Room or Cartop SRU by going to **MAIN MENU | DEBUG | ENTER CAR CALLS** and using the Up/Down arrow keys to select a floor to go to. Press the Enter button to latch that floor.

***NOTE: There will be a noticeable delay between the time a call is latched and the time the car actually initiates the call. This is normal because the call is initiated through the software and not the physical car call button.***

**\*\*\* Note: Before getting started, take a few minutes learning to navigate the LCD reader of the Smartrise board. The board and the menu options are the same for all locations (MR, CT or COP) and all menu items are located in Appendix A – Smartrise Menu Definitions \*\*\***

# SRU BOARD REVISION 8 LAYOUT

## Revision 8 Board





## SRU LED Indicator Table

Each LED on the SRU board has a reference designator next to it. The table below explains the function of each LED.

<i>Reference Designator</i>	<i>LED Color</i>	<i>What It Means When LED is On</i>
501-552	Green	Power is present on the corresponding input terminal.
601-624	Yellow	Output terminal is turned on.
061 / 062	Green	External power is applied to the board.
063	Green	Software on CPU-B (J22) is running when flashing.
064	Green	Software on CPU-A (J21) is running when flashing.
065	Red	Software has detected a fault.
071	Red	Board is resetting.
091	Green	Safety hardware is functional when flashing.
092	Red	Safety hardware has detected a fault.

You will notice that the LEDs come in three colors: red, yellow, and green.

- ❖ Red indicates a problem. Either a fault has been detected or the board is resetting.
- ❖ Yellow is used to indicate an active output terminal.
- ❖ Green is used to show power on an input terminal, power to the board, and as a “heartbeat” to show the software is running on the two processors.
- ❖ The heartbeat is displayed by the CPU LEDs (063 and 064) which flash when the board is functioning.

## Inputs

The input terminals are labeled 501 through 548. Each terminal has a green LED next to it which indicates when there is power present on the input. Inputs are designed for DC current only. **Putting AC current on an input will damage it.**

## Outputs

The yellow LED indicates the output transistor is on and current can flow through the output terminal. The output terminal provides a reference (REF) signal which means it will always connect to the negative side of the load. The positive side of the load should be connected to a +24vDC power source.

**\*\* Never connect +24vDC directly to the output terminal. Without a load to limit the current, the output transistor may be damaged. \*\***

When the yellow LED is off, it means the output transistor is also off which means any load connected to it will not be actuated.

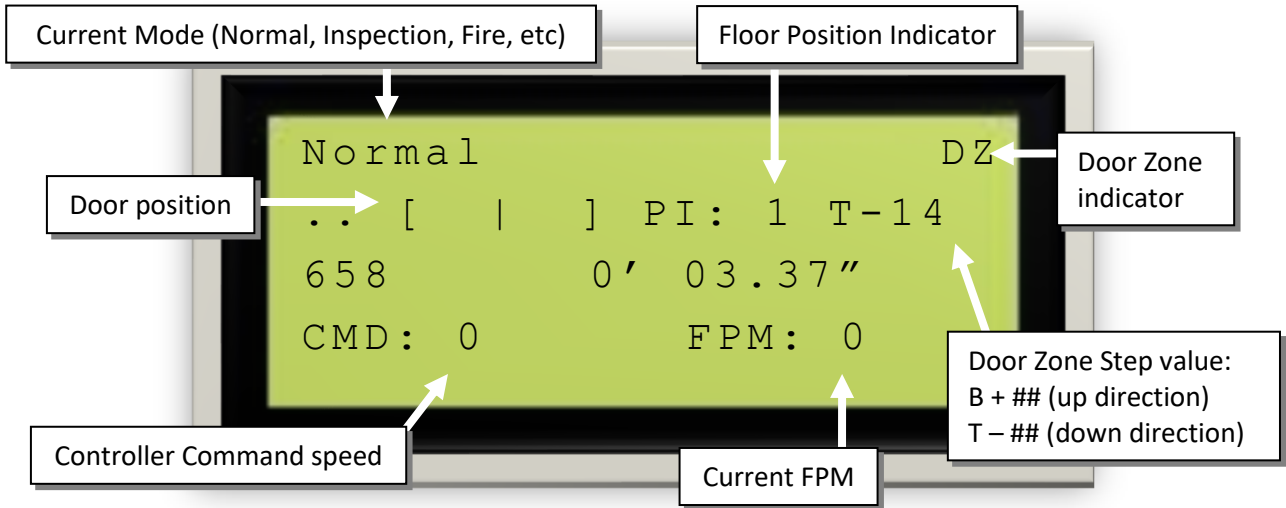
## DIP Switches and Jumpers (Rev 8 bds.)

The Revision 8 SRU board has two sets of DIP switches, each containing eight switches. The sets are labeled A and B and are located in the lower right area of the board. The table below explains their functions.

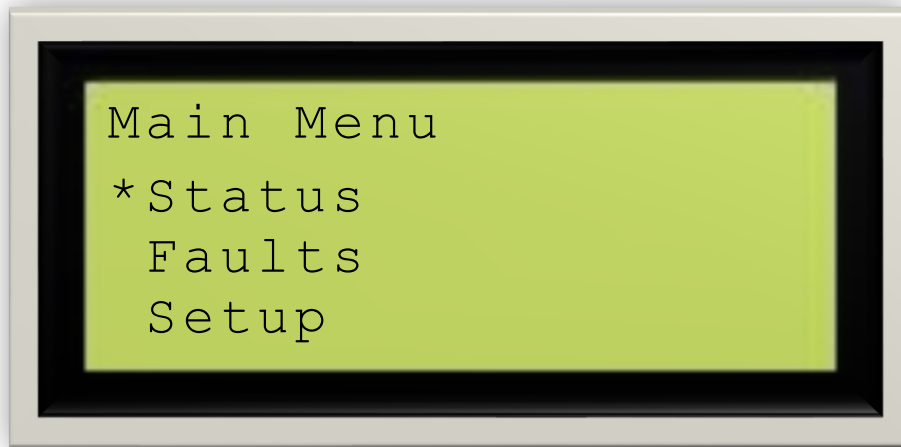
<b>DIP A Switch</b>	<b>Machine Room SRU Board</b>	<b>Car SRU Board</b>
1	CPU Stop Switch - Prevents car from running. When board is reset with switch on, it clears internal memory of latched faults and certain modes of operation (like Fire Service) that persist through a loss of power.	CPU Stop Switch Prevents car from running. Clears internal memory of latched faults and resets position count to 0 feet 0 inches.
2	Learn mode Puts car in Learn mode. Bypasses overspeed logic when on Inspection.	
3	Door Disable Turns off auto opening of car doors. Also prevents car from responding to hall calls.	
4		
5		
6	Pop-up blocker Prevents fault and alarm messages from automatically being displayed. You can still view them from the Active Faults screen.	Same as Machine Room SRU
7		
8	Preflight on Inspection Normally the preflight test is only performed when the car is in automatic mode. This switch forces the test to be performed even after an inspection run.	

# SMARTRISE SRU LCD SCREEN VIEWS

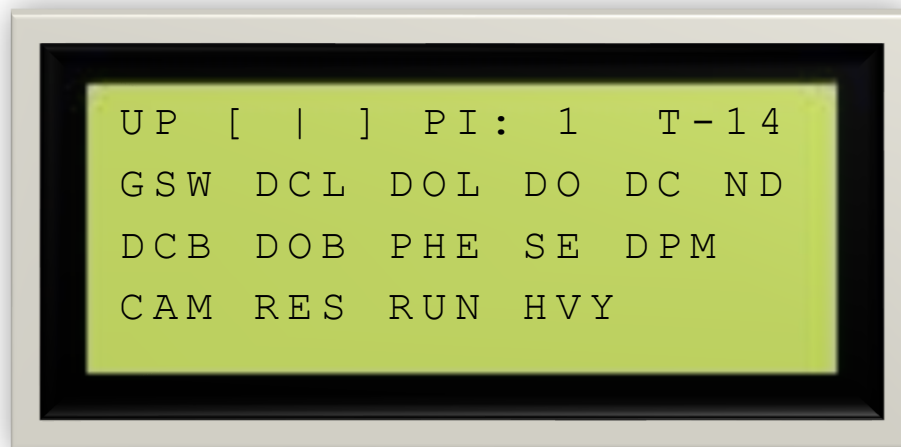
## Normal View Screen



## MAIN MENU SCREEN



## CAR DOOR DATA SCREEN (SEE NEXT PAGE)



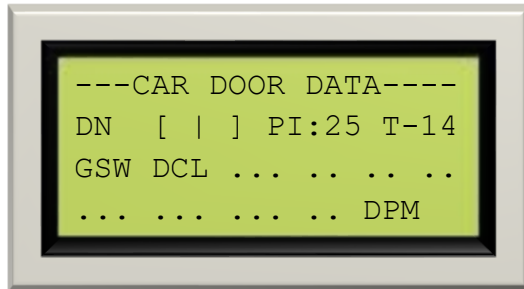
# Car Door Data Screen

These screens show the status of the door operator signals.

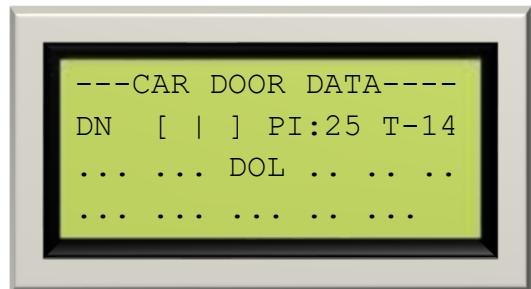
When the letters are visible the flag is being made.

Below are two examples of the car door status screen when Open and Closed:

Car Door Closed



Car Door Open



## --- CAR DOOR DATA ----

### FIRST LINE

1. UP / DN – Direction of travel
2. [ | ] – Door status
3. PI: – Position Indicator
4. T-# / B+# – Magnet steps (only in door zone)

### SECOND LINE

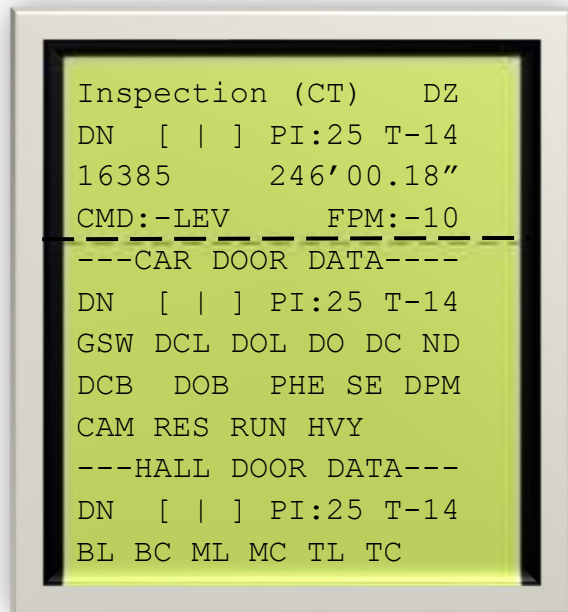
1. GSW – Gate Switch
2. DCL – Door Close Limit
3. DOL – Door Open Limit
4. DO – Door Open
5. DC – Door Close
6. ND – Nudge

### THIRD LINE

1. DCB – Door Close Button
2. DOB – Door Open Button
3. PHE – Photo Eye
4. SE – Safety Edge
5. DPM – Door Position Monitor

### FOURTH LINE

1. CAM – Door Cam
2. RES – Door Restrictor
3. RUN – Providing low current output to doors during travel
4. HVY – Used for heavy car/hall doors



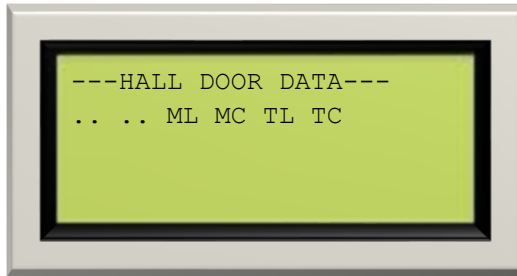
# Hall Door Data Screen

## --- HALL DOOR DATA ---

FIRST LINE – SAME AS CAR DOOR DATA

SECOND LINE

1. BL / BC – Bottom Hall Lock / Bottom Close Switch
2. ML / MC – Middle Hall Lock / Middle Close Switch
3. TL / TC – Top Hall Lock / Top Close Switch



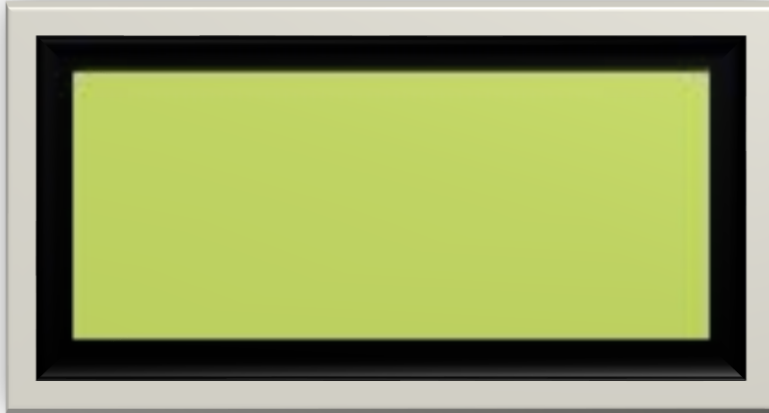
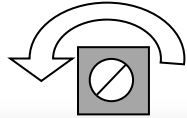
Bottom Hall Door Open –  
 BL / BC not flagging

### DOOR ICON MEANING

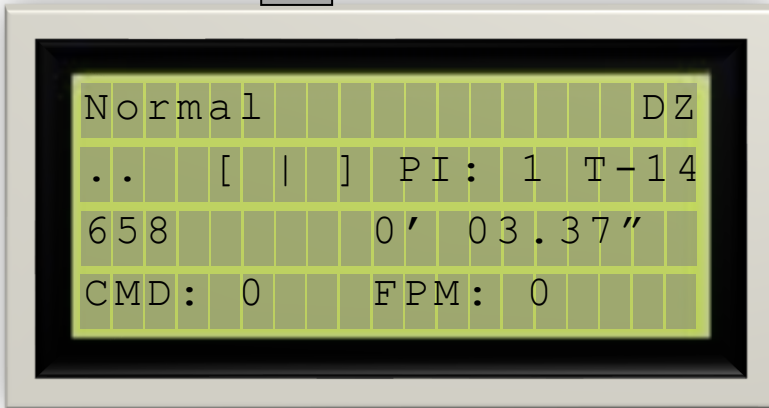
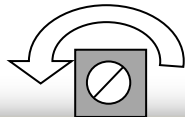
[   ]	Doors are fully closed
[ < > ]	Doors are opening
[     ]	Doors are fully open
[ > < ]	Doors are closing or nudging
[ <   > ]	Doors are opening but gate switch is still made
<     >	Doors are fully open but the Door Open output is still on
[     ]	Doors are ajar or not flagging properly – Unknown status

### Door Status Descriptions

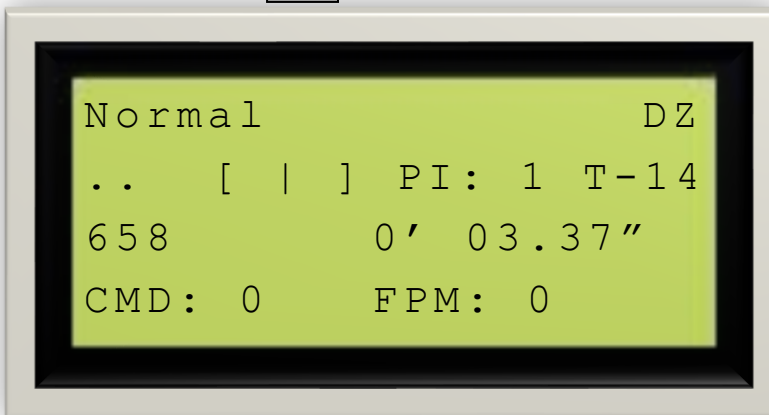
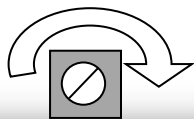
# Smarrise SRU LCD Screen Adjustment



If the LCD screen is blank but the LEDs on the SRU board are lit then adjust Potentiometer R249 (located above the LCD screen) counter-clockwise.



Keep turning Potentiometer R249 counter-clockwise until the display comes on. Caution: Turning Potentiometer R249 too far will cause dark boxes to appear around the letters and may burn out the LCD screen prematurely.



Turn Potentiometer R249 clockwise until the dark boxes disappear but you can still read the screen.

# GENERAL INSTALLATION

## IMPORTANT!

While Smartrise takes every measure to provide the customer with an out of box installation, sometimes incomplete information leads to default values being set on equipment and voltage settings. This is done to protect your equipment from overvoltage issues.

*[For example, the door operator for your job might operate on 240vac but Smartrise wasn't supplied with that information when the job was developed, therefore, the DR breaker (door operator voltage supply) will be set to 120vac for safety reasons.]*

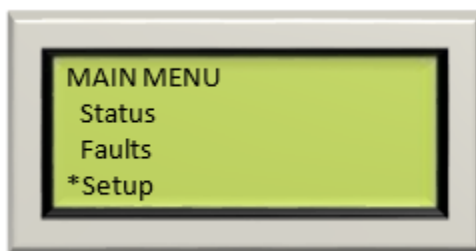
Please take a moment to verify that all required voltages for the existing equipment matches the voltages set by Smartrise PRIOR TO POWERING UP THE CONTROLLER. You can verify this with the drawings provided in your job binder.

## BYPASS TERM LIMITS

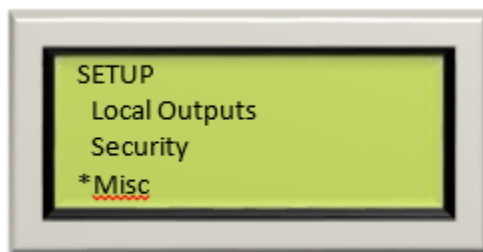
---

### (Check off box when complete)

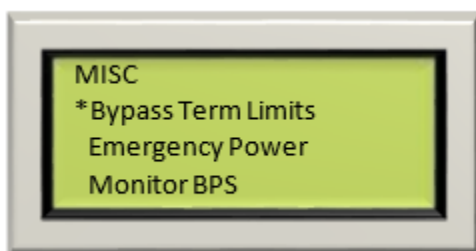
- Toggle the Inspection/Normal switch to the “INSP” position.
- Set **BYPASS TERM LIMITS** to **YES**:
- On the Smartrise Machine Room controller board, press the Left Arrow (ESC) button several times to get to the **MAIN SCREEN**.
- Press the Right Arrow to go to **MAIN MENU**. Use the Up / Down Arrow keys and move the asterix to **SETUP** and press the enter key.



- Use the Up / Down Arrow keys and move the asterix to **MISC** and press the enter key.

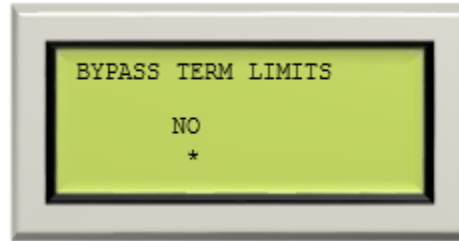


- BYPASS TERM LIMITS** should be the first item listed. If it's not, use the Up / Down Arrow keys and move the asterix to **BYPASS TERM LIMITS** and press the enter key.

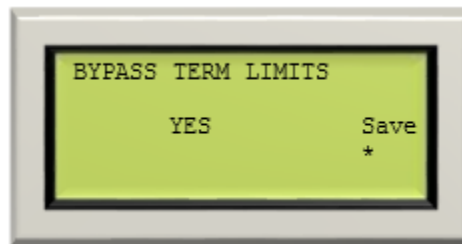




- Use the Up / Down Arrow keys to change the word “**NO**” to “**YES**”.



- Use the RIGHT Arrow key and move the asterix under the word “**SAVE**” and press enter.



- Hit the LEFT Arrow (ESC) button several times to get to the **MAIN SCREEN**.
- Verify the LCD displays “Construction” Mode on the **MAIN SCREEN**.

**Verify that the drive is not showing a fault on its display.**

# HYDRO INSTALLATION

## QUICK START MANUAL

Smartrise now sends a quick start manual inside the controller cabinet. These manuals allow the technician to get the controller running in Construction Mode. If the manual for the controller is missing it can be downloaded at:

<http://www.smartrise.us/support/>

# MAIN POWER SETUP

---

## Main Disconnect

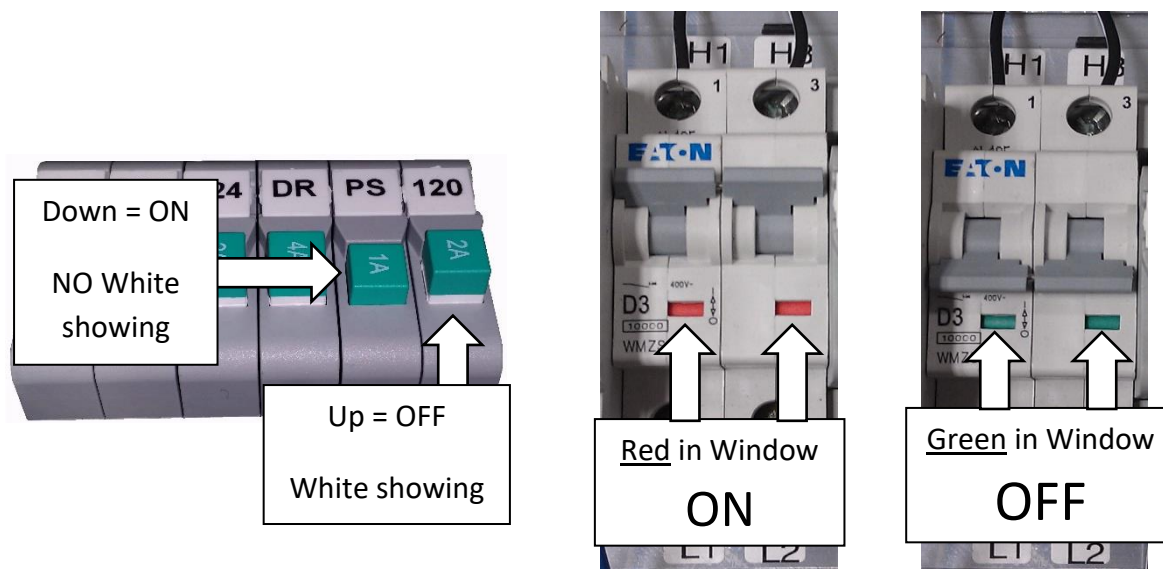
Verify that main disconnect is turned off prior to installing wiring on controller

## Push Button Breakers

Verify that all green push button breakers are in the up position (OFF).  
Do this for all 120vac, 240vac and 24vdc breakers.

## Controller Main L1/L2 Breaker

Verify that the L1/L2 breaker is in the OFF position (green shows in windows)



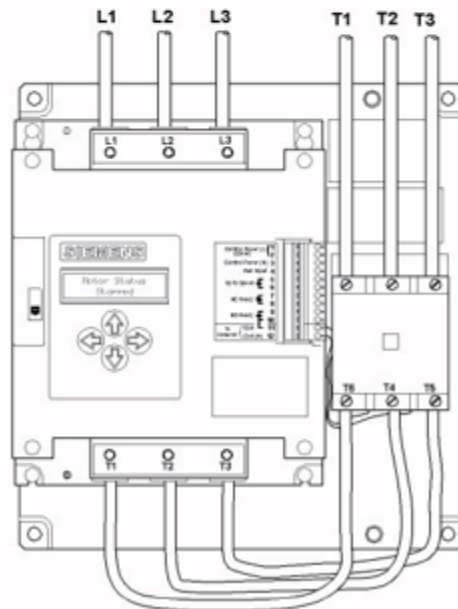
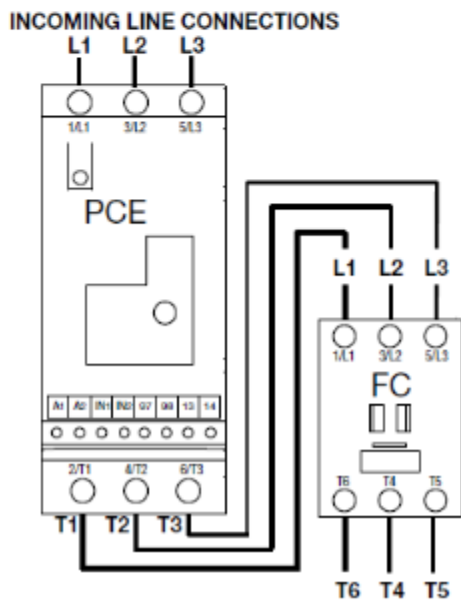
# MOTOR WIRING – 3/9 LEAD MOTOR WIRING

Connect motor leads to the terminals T1/T2/T3 on the fault contactor.

Terminals		T6	T4	T5	JUMP
3-Lead Motor	(208-575vac)	1	2	3	N/A
9-Lead Motor	Low Voltage (220-240vac)	1,6,7	2,4,8	3,5,9	N/A
	High Voltage (460-480vac)	1	2	3	4 & 7 5 & 8 6 & 9

**3-Lead Line Wiring -  
Sprecher & Schuh  
Dip #15 = ON**

**3-Lead Line Wiring -  
Siemens**



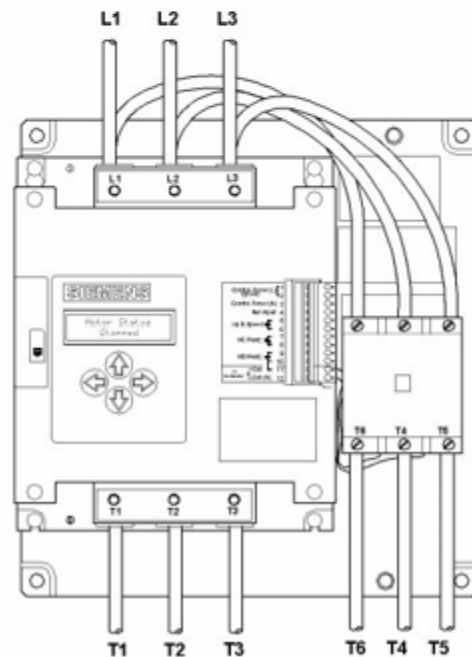
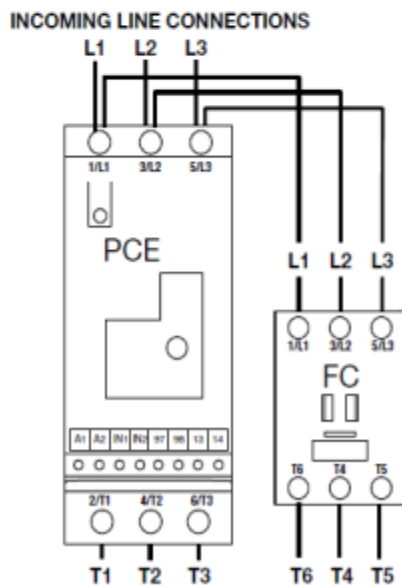
# MOTOR WIRING – 6/12 LEAD MOTOR WIRING

Connect motor leads to terminals T1/T2/T3 on the softstart and T6/T4/T5 on the fault contactor.

Terminals		T1	T2	T3	T4	T5	T6	JUMP
Single Voltage	(208-575vac)	1	2	3	4	5	6	N/A
Dual Voltage	Low (220-240vac)	1,7	2,8	3,9	10,4	11,5	12,6	N/A
	High (460-480vac)	1	2	3	10	11	12	4 & 7 5 & 8 6 & 9

**6-Lead Delta Wiring -  
Sprecher & Schuh  
Dip #15 = OFF**

**6-Lead Delta Wiring -  
Siemens**



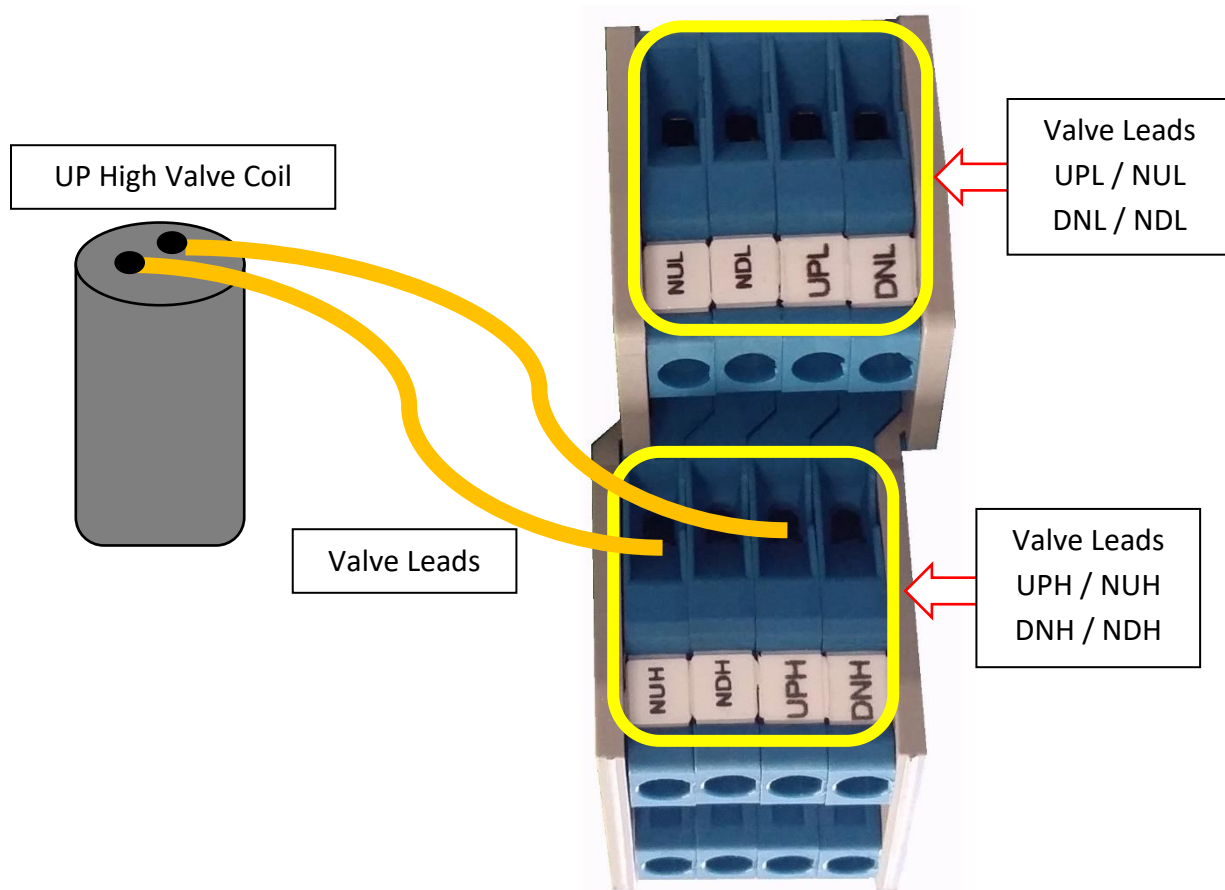
# VALVE WIRING

Wire the valve solenoids to the Machine Room DIN Rail terminals.

One lead of each valve solenoid goes to the “N” UP/DN (Neutral) DIN Rail terminals and the other lead goes to the corresponding High/Low UP/DN DIN rail terminals. See drawings for connection reference.

Refer to “*Sheet 4 – Drive and Motor*” for voltage requirements.

UPH	Up High valve coil	NUH	Neutral Up High
UPL	Up Low valve coil	NUL	Neutral Up Low
DNH	Down High valve coil	NDH	Neutral Down High
DNL	Down Low valve coil	NDL	Neutral Down Low



# SOFT START SETUP – SPRECHER + SCHUH

---

## SETUP

- Verify the motor line or delta configuration and ensure that DIP switch 15 on the Soft Starter reflects this configuration.
- If the Soft Start faults out upon initial up run command, check for a red-blinking LED on the Soft Start and count the number of times it illuminates sequentially before a brief pause.
  - The most likely cause is a line rotation issue which can be resolved by switching T1 & T2 motor leads or change DIP switch 9 on the soft starter to its alternate position (refer to “**Sprecher + Schuh PCE Soft Start Dip Switch Settings**”).
  - After changing the position of this switch, press the Reset Button adjacent to the DIP switch group.
- A noisy pump motor usually indicates a motor wiring issue. Check the pump motor wiring and make sure it’s connected per the manufacturers specifications.
- If problems persist, refer to the Sprecher + Schuh manual for all faults associated with the light.

## IMPORTANT!

**Smarrise controllers purchased through a packager will not have the softstart pre-installed. When installing a softstart not purchased from Smarrise, make sure ALL FACTORY JUMPERS are removed unless shown on the Smarrise drawings. Improper voltages caused by factory jumpers may damage the controller!**

# Troubleshooting

If the Smartrise controller indicates a “Drive Fault” and the softstart has the fault LED flashing, refer to the following table for troubleshooting:

<b>Sprecher + Schuh LED Fault Indication and Diagnostics</b>			
<b>Flashes</b>	<b>Fault Type</b>	<b>Possible Fault Explanations</b>	<b>Possible Solutions</b>
1	Overload	<ul style="list-style-type: none"> <li>Motor Overload condition present</li> <li>FLA dial adjustment not matched to motor</li> </ul>	<ul style="list-style-type: none"> <li>Check for motor overload condition</li> <li>Verify actual motor current does not exceed FLA</li> <li>Verify/Reset FLA Dial adjustment</li> <li>Program/modify Overload setting for load or duty cycle required</li> </ul>
2	Over Temperature	<ul style="list-style-type: none"> <li>Controller ventilation blocked</li> <li>Controller duty cycle exceeded</li> <li>Cooling fan not working</li> <li>Ambient temperature exceeded</li> <li>Failed control module</li> <li>Over-current condition with</li> <li>Overload disabled</li> </ul>	<ul style="list-style-type: none"> <li>Check for proper ventilation</li> <li>Verify duty cycle</li> <li>Connect or replace cooling fan</li> <li>Wait for controller to cool or provide external cooling</li> <li>Replace control module</li> </ul>
3	Phase Reversal	<ul style="list-style-type: none"> <li>Incoming supply voltage is not the expected sequence of either ABC or CBA</li> </ul>	<ul style="list-style-type: none"> <li>Check power wiring</li> <li>Change two of the incoming phases and verify that the motor is spinning in the correct direction. If the motor does not turn in the correct direction, change the incoming phases back to their original connections and change dip switch #9 to the desired Line Rotation sequence setting.</li> </ul>
4	Phase Loss/ Open Load	<ul style="list-style-type: none"> <li>Missing Supply Phase</li> <li>Missing or unable to detect motor connection</li> </ul>	<ul style="list-style-type: none"> <li>Check that the fault contactor is closing. If not, verify that the safety string is closed or jumped out.</li> <li>Check for open line (i.e. open fuse)</li> <li>Check for incorrect wiring to load</li> <li>Verify proper operation of the fault contactor</li> <li>Verify connection type to motor (LINE or DELTA)</li> <li>Ensure product is sized correctly for motor</li> </ul>
5	Phase Imbalance	<ul style="list-style-type: none"> <li>Unbalanced Phase Currents ( &gt; 65% differential)</li> <li>Incoming Line voltage problem</li> </ul>	<ul style="list-style-type: none"> <li>Check motor current in each phase to verify imbalance. Motor current imbalance can indicate potential motor problems</li> </ul>
6	Shorted SCR	<ul style="list-style-type: none"> <li>Shorted SCR</li> <li>Welded or latched Bypass contactor</li> </ul>	<ul style="list-style-type: none"> <li>Verify connection type (LINE or DELTA) and verify setting</li> <li>Perform continuity check across power poles (L1 – T1, L2 – T2, L3 – T3). Measurements should exceed 10 k ohms. For best results remove line and load motor connections.</li> <li>Cycle power to device and attempt to restart, if fault persists replace device</li> </ul>
7	Test	<ul style="list-style-type: none"> <li>Intended operation</li> </ul>	<ul style="list-style-type: none"> <li>Reset Fault</li> </ul>
12	Checksum	<ul style="list-style-type: none"> <li>Internal Software corruption</li> </ul>	<ul style="list-style-type: none"> <li>Replace Device</li> </ul>



- 1) If the pump is too noisy or the motor is running in the wrong direction, it can usually be fixed by swapping any two main lines.
- 2) If the car doesn't move verify that the valve relays are turning on when a direction is given (i.e. UPL and SM for Up direction, DNL for Down direction). If they are then check the wiring and voltages to the valves.
- 3) At this point the car should be able to run using Construction Mode. Use this mode to adjust your valves, install the traveler, tape, and the permanent safety string.
- 4) Adjust your valves as required to get proper starts, stops, and run speeds. There are two parameters that affect the pump motor during starts and stops.
  - a. **MAIN MENU | SETUP | TIMERS | UP TO SPEED DELAY**
    - i. This parameter allows the pump motor to run for a specified amount of time at the start of a run before opening the UP valves.
  - b. **MAIN MENU | SETUP | TIMERS | PUMP OFF DELAY**
    - i. This parameter allows the pump motor to continue running for a specified amount of time at the end of a run after closing the UP valves.

## Sprecher + Schuh PCE Soft Start Dip Switch Settings

The PCE elevator controller is programmed through dipswitches located on the front of the controller. **Default settings are indicated by the shaded areas.**

START TIME				
SETTING (SECONDS)	DIP SWITCH # 1	DIP SWITCH # 2	DIP SWITCH # 8	This defines the time the controller will ramp or limit current to the motor. The controller can determine when the motor is 'up-to-speed', therefore it may transition to bypass before this time expires. If the motor does not reach speed before the time expires, the controller will continue under SCR control and not close the bypass contactor.
2	OFF	OFF	OFF	
5	ON	OFF	OFF	
10	OFF	ON	OFF	
15	ON	ON	OFF	

START MODE		
MODE SETTING	DIP SWITCH # 3	In Current Limit mode, a set level of current is applied to the motor over the start time. In Soft Start mode, the device will ramp the torque from the initial level to 100% over the start time.
CURRENT LIMIT	OFF	
SOFT START	ON	

CURRENT LIMIT / INITIAL TORQUE LEVEL			This defines the time the controller will ramp or limit current to the motor. The controller can determine when the motor is 'up-to-speed', therefore it may transition to bypass before this time expires. If the motor does not reach speed before the time expires, the controller will continue under SCR control and not close the bypass contactor.
%FLA / %TORQUE	DIP SWITCH # 4	DIP SWITCH # 5	
<b>150% / 15%</b>	<b>OFF</b>	<b>OFF</b>	
<b>250% / 25%</b>	<b>ON</b>	<b>OFF</b>	
<b>350% / 35%</b>	<b>OFF</b>	<b>ON</b>	
<b>450% / 65%</b>	<b>ON</b>	<b>ON</b>	

SOFT START TIME			Soft Stop reduces the voltage applied to the motor over the programmed period of time. The soft stop is complete when the soft stop timer has expired or the current measured drops below 50% of the FLA setting.
SETTING (SECONDS)	DIP SWITCH # 6	DIP SWITCH # 7	
<b>OFF</b>	<b>OFF</b>	<b>OFF</b>	
<b>1 X START TIME</b>	<b>ON</b>	<b>OFF</b>	
<b>2 X START TIME</b>	<b>OFF</b>	<b>ON</b>	
<b>3 X START TIME</b>	<b>ON</b>	<b>ON</b>	

PHASE ROTATION			The allowable phase rotation of the motor is defined by this switch.
SETTING	DIP SWITCH # 9		
<b>ABC ROTATION</b>	<b>OFF</b>		
<b>CBA ROTATION</b>	<b>ON</b>		

PHASE IMBALANCE			The controller has the ability to monitor for imbalance between phase currents. This protection feature can be user disabled.
SETTING	DIP SWITCH # 10		
<b>ENABLED</b>	<b>OFF</b>		
<b>DISABLED</b>	<b>ON</b>		

OVERLOAD TRIP CLASS			The controller incorporates, as standard, electronic overload protection. This motor overload protection is accomplished electronically with the use of internal current transformers on each of the three phases. The controller's overload protection is programmable, providing the user with flexibility.
SETTING	DIP SWITCH # 11	DIP SWITCH # 12	
<b>OFF</b>	<b>OFF</b>	<b>OFF</b>	
<b>10</b>	<b>ON</b>	<b>OFF</b>	
<b>15</b>	<b>OFF</b>	<b>ON</b>	
<b>20</b>	<b>ON</b>	<b>ON</b>	

OVERLOAD RESET			In manual reset mode, the fault can only be reset by pushing the 'push to reset' button on the front of the controller. In auto reset mode, the unit will automatically reset when unit determines the motor has cooled to 75% of its thermal capacity.
SETTING	DIP SWITCH # 13		
<b>MANUAL</b>	<b>OFF</b>		
<b>AUTO</b>	<b>ON</b>		

AUX#1 SETTING			The operation defines the operation of the Auxiliary contacts. Normal mode means that the contact will change state immediately when a start/run command is given. Up-to-Speed mode means that the contact will change state only when the controller is in bypass. Aux#2 when added will operate opposite of this programming.
SETTING	DIP SWITCH # 14		
<b>NORMAL</b>	<b>OFF</b>		
<b>UP TO SPEED</b>	<b>ON</b>		

MOTOR CONNECTION TYPE			In DELTA connection mode, the device is designed to control a 6 or 12 lead motor. In LINE connection mode, the device is designed to control a 3 or 9 lead motor.
SETTING	DIP SWITCH # 15		
<b>DELTA</b>	<b>OFF</b>		
<b>LINE</b>	<b>ON</b>		

STOP DELAY			When the delay is programmed, the motor will continue to run for the programmed period of time after the run command is removed from the controller.
SETTING	DIP SWITCH # 16		
<b>0.0 SEC</b>	<b>OFF</b>		
<b>0.75 SEC</b>	<b>ON</b>		

# SOFT START SETUP – SIEMENS

---

## SETUP

- If the Soft Start displays a fault on the LCD screen, refer to the provided Siemens manual for troubleshooting.
- If the initial fault is for an “out of line rotation” condition, remedy this by swapping motor wires (T1 and T3 with power off) or change the “line rotation” (ABC to CBA or vice versa) found in the Parameter Menu of the Soft Start.
- A noisy pump motor usually indicates a motor wiring issue. Check the pump motor wiring and make sure it’s connected per the manufacturers specifications.
- Proceed to “Troubleshooting” section if necessary.

## IMPORTANT!

Smartrise controllers purchased through a packager will not have the softstart pre-installed. When installing a softstart not purchased from Smartrise, make sure **ALL FACTORY JUMPERS** are removed unless shown on the Smartrise drawings. Improper voltages caused by factory jumpers may damage the controller!

## Siemens LCD Troubleshooting Table

Symptom	LCD Indication	Problem	Solution
LCD not working	No characters displayed on the LCD screen.	Voltage too low or not present at Control Power terminals 1 and 3	Confirm that control voltage is 120VAC between terminals 1 and 3
		Defective Starter	If the voltage is greater than 85 VAC replace the starter
Motor will not start	Status Ready	Voltage too low or not present at Run Input terminal 4	Confirm that voltage of 120VAC is present between terminal 3 and Run Input terminal 4 If there is at least 80 VAC present, and the screen still displays "Ready", replace the starter.
	Control Voltage Powered Down	Voltage too low at Control Power Input.	If the voltage is less than 105 VAC, correct the voltage problem. If the voltage is greater than 105 VAC replace the starter.
	Control Voltage Brown Out	Voltage too low at Control Power Input.	If the voltage is less than 105 VAC correct the voltage problem. If the voltage is greater than 105 VAC replace the starter.
	Control Voltage Over Voltage	Voltage too high at Control Power Input.	If the voltage is greater than 140 VAC, correct the voltage problem If the voltage is less than 140 VAC and the starter is indicating this fault, check for distortion at the peaks of the waveform. Contact Technical support for further information.
	Fault EEPROM Memory	The Starter has detected a problem with the EEPROM Memory	Replace the starter.
	Fault ROM Memory	The Starter has detected a problem with the ROM Memory	Replace the starter.
	Fault Watchdog	The Starter has detected an internal fault.	Replace the starter.
	Wrong Rotation CBA set as ABC or Wrong Rotation ABC set as CBA	Incoming three phase is opposite of the Line Rotation Setting	<b>Disconnect Line Power:</b> Change two of the incoming phases and verify that the motor is spinning in the correct direction. If the motor does not turn in the correct direction, change the incoming phases back to their original connections and go to the Parameter menu to change the Line Rotation setting.
	Fault Motor Wiring	The motor is not correctly connected to the starter.	<b>Disconnect Line Power:</b> For In Delta Applications the following measurements should be less than 10 ohms: t1 to center leg, bottom of Fault Contactor t2 to right leg, bottom of Fault Contactor t3 to left leg, bottom of Fault Contactor  For In Line applications, the following measurements should be less than 10 ohms t1 to t2 -- t2 to t3 -- t3 to t1 -- Correct wiring if necessary

<b>Motor will not start (cont.)</b>		The Fault Contactor is not being energized	<p>Verify that the fault contactor is being energized after power up. You should hear it pull in then drop out upon power up.</p> <p>If not, measure the voltage from terminal 9 to terminal 12. This should be 110 VAC. Correct any wiring errors if necessary. Connect a voltmeter to terminals 9 and 12. Push the up and down arrows simultaneously and look for the voltage to appear briefly across these terminals.</p> <p>Correct any wiring errors if necessary. If the particular elevator's controls require the fault contactor be cycled with each run, the starter can be configured to check for motor wiring faults only when the motor run command is initiated. Consult technical support for further assistance.</p>
		Motor is wired correctly, starter still indicates Motor Wiring fault.	<p><b>Disconnect line power.</b></p> <p>With an ohmmeter, check for a shorted SCR by measuring the resistance of each phase from the line to load terminals. A shorted SCR typically has a resistance of less than 3000 Ohms. If all three S.C.R.s are acceptable, proceed with the next steps.</p> <p>Move the jumper wire from 9 to 10 on the terminal block.</p> <p>Re-energize equipment.</p> <p>Verify that the fault contactor is energized and remains in.</p> <p>Measure the voltages across the poles of the fault contactor.</p> <p>If all voltages are less than 5 VAC <b>Disconnect line power</b> the equipment and move the jumper wire back to terminal 9.</p> <p>If any of the poles have voltages higher than 5 VAC, contact technical support for further assistance.</p>
	<b>Fault Shorted SCR A or Fault Shorted SCR B or Fault Shorted SCR C</b>	The Starter has a shorted S.C.R. in the indicated phase	<p><b>Disconnect line power.</b> With an ohmmeter, check for a shorted SCR by measuring the resistance of each phase from the line to load terminals. A shorted SCR typically has a resistance of less than 3000 Ohms. If the S.C.R.s are acceptable, and the wiring configuration is In Line, Consult Technical Support for Further information.</p>
	<b>Fault Highline Volts</b>	The unit has detected a highline condition on the incoming voltage lines.	<p>Check the Line Voltages in the Status Menu. If one or more of the incoming lines are over 528 volts for 460 volts units or 632 volts for 575 volt units, verify the reading with a meter. If the meter reading matches the starter's reading, correct the voltage problem. If the meter reading does not agree with the starters voltage reading, contact technical support.</p>
<b>Motor Starts, but does not come up to speed in a</b>	<b>Status Maintain Start</b> before switching to <b>Status</b>	Current limit is set too low or there is an excessive load on the system during the start.	<p>Check the current limit setting in the Parameter menu. This should not be set below 200%. Verify that the overload setting is correct.</p> <p>Verify that the valves are not being energized during the start.</p>

timely manner, or at all.	Ramp to 450%		Increase current limit if necessary. If using the starter "In Line", verify that the unit is sized correctly for the motor.
Motor trips out on a fault after coming up to speed.	Fault Low Leg Amps	The starter has detected an imbalance in the motor currents	Check the fault currents in the Fault Menu or with a computer or PDA using the required interface. Compare these to the currents seen during the start and before the faults occur. If possible, verify the currents with a clamp on ammeter. Check the voltages across the SCRs, by measuring across the line and load terminals, when the unit is up to speed. These voltages should be less than a few volts. If any are above 10 VAC, contact technical support. The Default trip point for the ratio of the lowest to the highest current is .33. This setting is adjustable in the OEM menu accessible via a password. If the setting has to be adjusted, contact technical support.
	Fault Phase Loss	The starter detected a problem with the incoming three phase power during a run condition.	This fault will reset when the power returns to normal. To view the exact line voltages when the fault occurred, view the diagnostic screen via a laptop computer or PDA.
Motor trips out on an Overload fault after coming up to speed.	Fault Overload	The Overload setting is set too low.	Check the fault currents, Run Status and Run Time; accessible in the Fault Menu or with a computer or PDA using the required interface. For Inside Delta applications, displayed fault currents should be multiplied by 1.73 to get an approximate line value. Verify the fault occurred during the "Maintain Current Limit", "Ramp to 450%" or "Maintain 450%". Verify the starting current limit is set to at least 200% of the motor FLA. If the overload fault is occurring during the "maintain 450%" and the run time is several seconds, there may be a mechanical issue preventing the motor from coming up to speed. Verify that there is some type of viscosity control, either heaters or re-circulation. If this is not the case, contact technical support for assistance on configuring the "Instantaneous Stall Protection".
		The Starter has detected an Overload condition while up to Voltage	The overload setting should be set to the FLA of the motor. See Figure 8 for the Class 72 starter trip curves. If the overload is set correctly you need to determine the cause of the higher currents. If the fault currents multiplied by 1.73 are in excess of the Power Unit's rated amps under a Full load condition, there may be a mechanical problem. In addition to the above, if the overload mode is set for "All 3 Phases" and one winding's current is significantly higher than the other windings, nuisance overload trips may occur during long up runs near or at the rated up load.



## Soft Start setup

- 1) Apply Main Line Power.
  - a. The LCD on the Smartrise board should come on.
  - b. Verify the Soft Start is not showing a fault.
- 2) SIEMENS:
  - a. If the Soft Start is a Siemens, it will display “Fault” on the LCD. If the Soft Start displays a fault, refer to the provided Siemens manual for troubleshooting.
  - b. If the initial fault is for an “out of line rotation” condition, remedy this by swapping motor wires (T1 and T3 with power off) or change the “line rotation” (ABC to CBA or vice versa) found in the Parameter Menu of the Soft Start.
  - c. Proceed to “Troubleshooting” section if necessary.
- 3) SPRECHER + SCHUH:
  - a. Verify the motor line or delta configuration and ensure that DIP switch 15 on the Soft Starter reflects this configuration.
  - b. If the Soft Start faults out upon initial up run command, check for a red-blinking LED on the Soft Start and count the number of times it illuminates sequentially before a brief pause.
  - c. The most likely cause is a line rotation issue which can be resolved by switching T1 & T3 motor leads or change DIP switch 9 on the soft starter to its alternate position (refer to soft start manual for dip switch location).
  - d. After changing the position of this switch, press the Reset Button adjacent to the DIP switch group.
  - e. If problems persist, refer to the manual for all faults associated with the light.

## Troubleshooting

- 1) If the pump is too noisy or the motor is running in the wrong direction, it can usually be fixed by swapping any two main lines.
- 2) If the car doesn't move check the wiring and voltages to the valve coils.
- 3) At this point the car should be able to run using Construction Mode. Use this mode to adjust your valves, install the traveler, tape, and the permanent safety string.

- 4) Adjust your valves as required to get proper starts, stops, and run speeds. There are two parameters that affect the pump motor during starts and stops.
  - a. **MAIN MENU | SETUP | TIMERS | UP TO SPEED DELAY**
    - i. This parameter allows the pump motor to run for a specified amount of time at the start of a run before opening the UP valves.
  - b. **MAIN MENU | SETUP | TIMERS | PUMP OFF DELAY**
    - i. This parameter allows the pump motor to continue running for a specified amount of time at the end of a run after closing the UP valves.
- 5) If you're still experiencing problems running in Construction Mode, use the following checklist to verify wiring and setup.

#### **HYDRO CONSTRUCTION MODE CHECKLIST**

- Clear all faults on controller and Soft Start
- Verify incoming power to controller and Soft Start
- Verify all breakers are turned on
- Make sure "Bypass Term Limits" is set to "Yes"
- Turn Inspection Switch to "Inspection"
- Install jumper from 120 terminal to SF1 terminal on DIN rail. If Run box installed, verify switch is closed
- Install jumper from 120 terminal to TL, ML & BL terminals
- Install jumper from M24 to Input 523 (Construction)
- Wire UP HIGH valve between UPH and NUH terminals on Din Rail
- Wire UP LOW valve to UPL and NUL terminals on Din Rail
- Wire DOWN HIGH valve to DNH and NDH terminals on Din Rail
- Wire DOWN LOW valve to DNL and NDL terminals on Din Rail



# AC TRACTION INSTALLATION

## QUICK START MANUAL

Smartrise now sends a quick start manual inside the controller cabinet. These manuals allow the technician to get the controller running in Construction Mode. If the manual for the controller is missing it can be downloaded at:

<http://www.smartrise.us/support/>

# MAIN POWER SETUP

---

## Main Disconnect

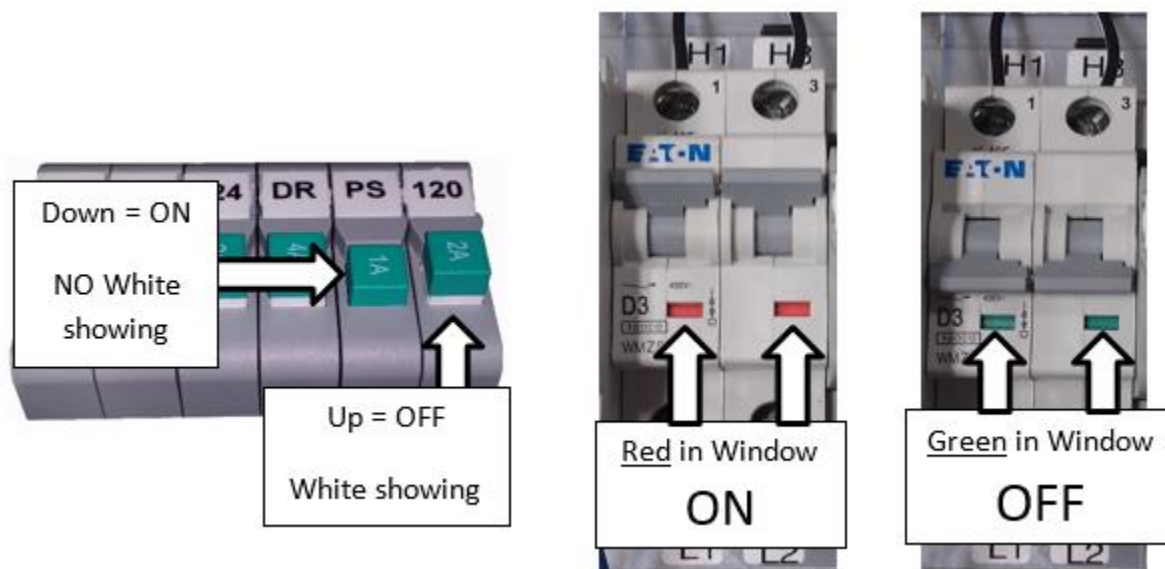
Verify that main disconnect is turned off prior to installing wiring on controller

## Push Button Breakers

Verify that all green push button breakers are in the up position (OFF).  
Do this for all 120vac, 240vac and 24vdc breakers.

## Controller Main L1/L2 Breaker

Verify that the L1/L2 breaker is in the OFF position (green shows in windows)



# MOTOR & BRAKE WIRING

## Main Line Connection

Connect main line power to terminal block L1/L2/L3.

## Ground Connection

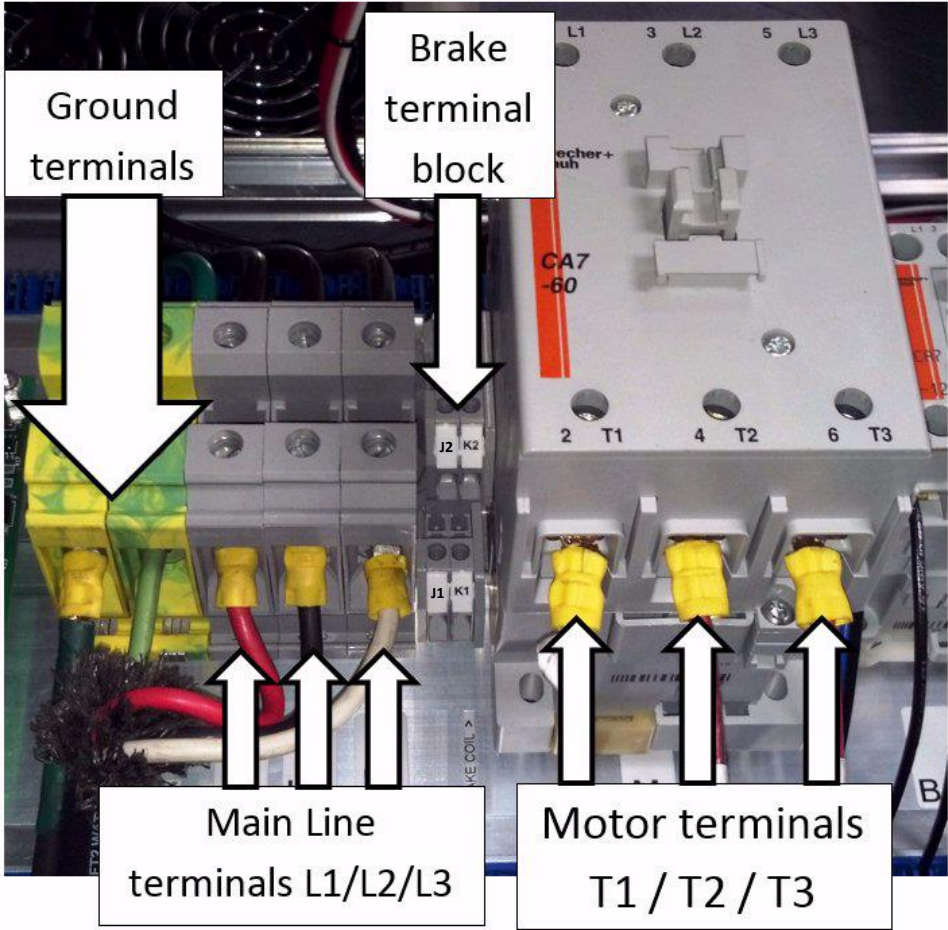
Connect the ground wire to the yellow/green terminal block next to L1-L3. Refer to page 4 of the manual for proper grounding requirements.

## Motor Connection

Connect motor leads to the M contactor at terminals T1/T2/T3.

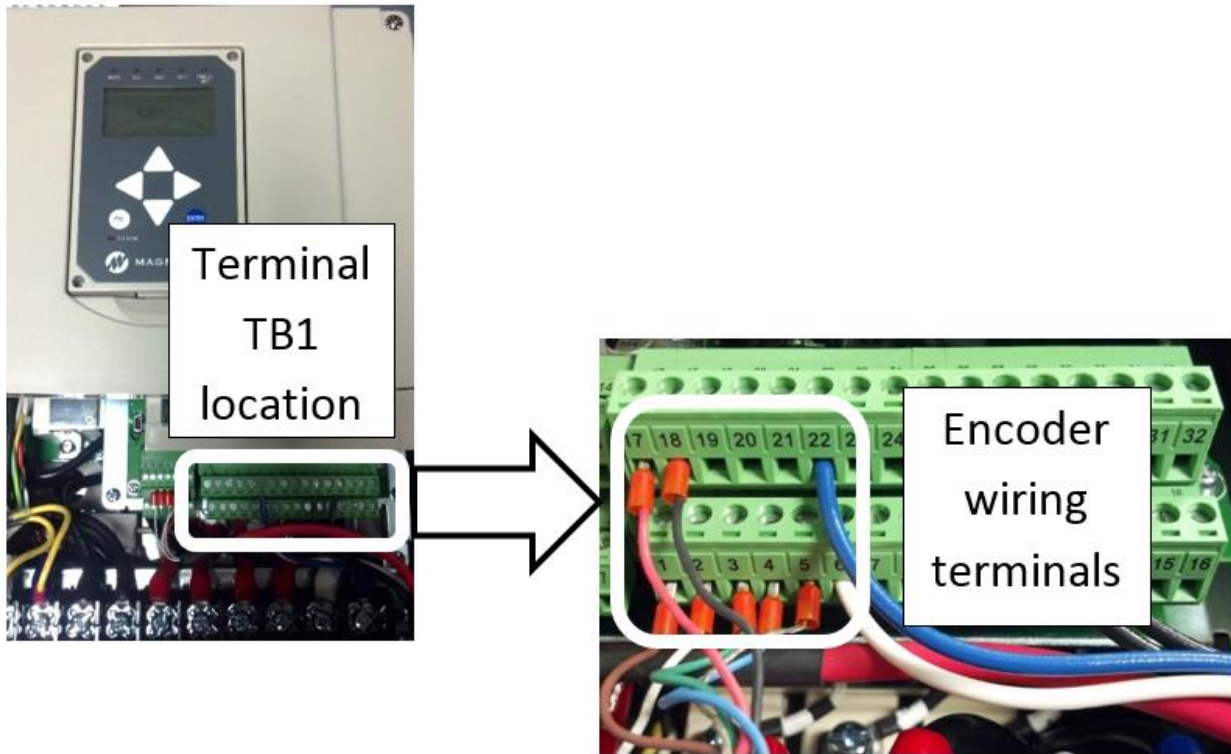
## Brake Terminal

Connect the main brake wiring to terminals K1 / K2 (J1 / J2 is optional for 2<sup>nd</sup> brake) located on the terminal block next to the M contactor.



# ENCODER WIRING (INSTRUCTIONS PER MANUFACTURER DRIVE TYPE)

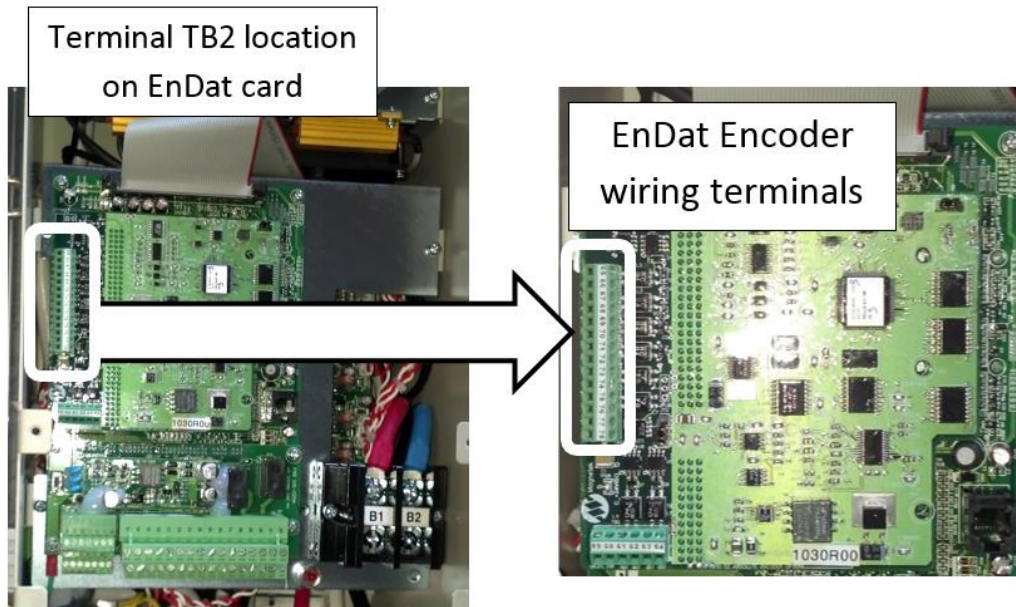
## Encoder Terminal Locations – (HPV – Inductions Only)



Terminal Description Table			
Drive_TB2	Drawing (Sheet 4)	Description	On Site Colors
17	V+ (PWR)	+5v Power	
18	V- (COM or GND)	Common or Ground	
1	A+ (A)		
2	(A/)		
3	B+ (B)		
4	B- (B/)		
5	Shield	Shield Ground	

## Encoder Terminal Locations – HPV900s2 – (PMs Only)

Connect the encoder cable to terminal block TB2 on the EnDat Card located under the top cover. Write the existing encoder wire colors for this job in the column provided.



Encoder	HPV900 S2 EnDat Termination		Cable Color				On Site Color
			Black Heidenhain	Ziehl	Green Encoder Cable	Torin Encoder Cable	
A/	A-	TB2-1	Yellow & Black	Red & Blue	Yellow	Brown	
A	A+	TB2-2	Green & Black	Grey & Pink	Green	Green	
B/	B-	TB2-3	Red & Black	Red	Red	Yellow	
B	B+	TB2-4	Blue & Black	Blue	Blue	Blue	
Data/	DAT-	TB2-5	Pink	Brown	Pink	Silver	
Data	DAT+	TB2-6	Grey	White	Grey	Grey	
Clock/	CLK-	TB2-7	Yellow	Black	Violet	White	
Clock	CLK+	TB2-8	Violet	Violet	Black	Violet	
0V com	COM	TB2-9	Green & White	Pink	White	Black/red & white	
+5V	+5V	TB2-10	Green & Brown	Grey	Brown	Red&Pink	
0V Sense (if present)	SEN-	TB2-11	White	Yellow	-	-	
+5V Sense (if present)	SEN+	TB2-12	Blue	Green	-	-	
Cable Shield	SHLD	TB2-13	Encoder Cable Shield	Encoder Cable Shield	Encoder Cable Shield	Red	
EnDat Board Ground (Magnetek GRN factory wire tied to ground stud)	SHLD	TB2-13	-	-	-	-	

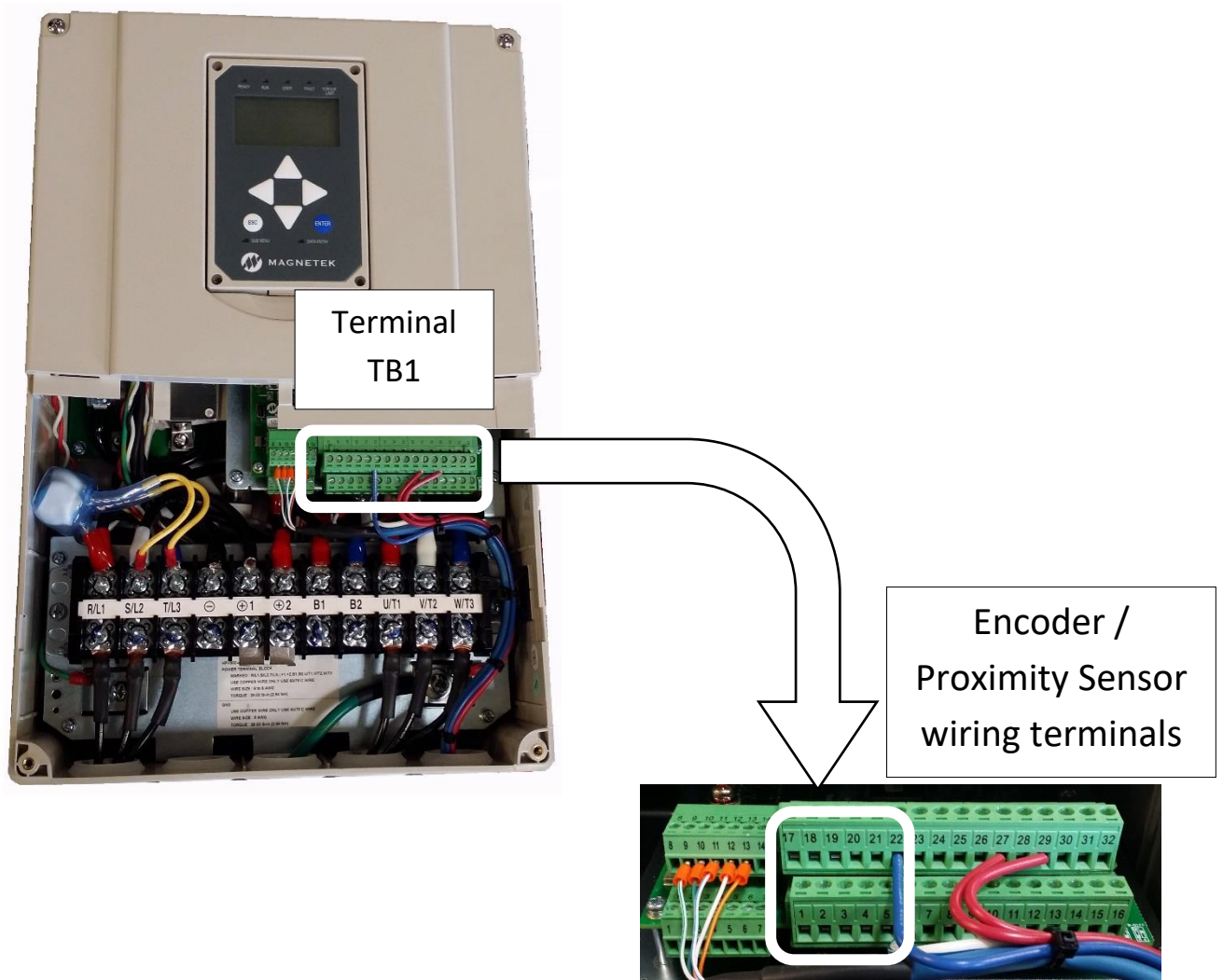
Table 1 PM: Connections and color scheme of recommended absolute encoders



## Encoder Terminal Locations – HPV900s2 Axial Flux – (PM Only)

Connect the encoder cable and the proximity sensor cable to terminal block TB1 on the drive located under the bottom cover.

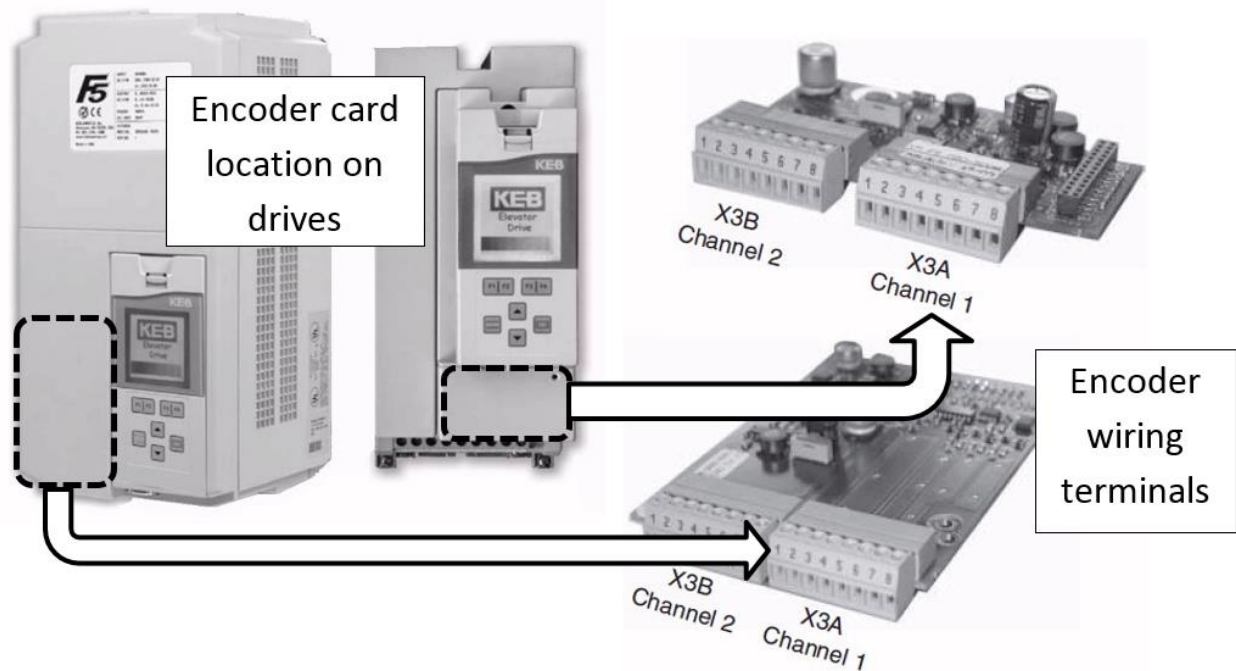
Terminal # on TB1	Motor Encoder	Proximity Sensor
1	A	
2	/A	
3	B	
4	/B	
5	Shield	Shield
17	+VDC	+VDC
18	COM	COM
19		Z



## Encoder Terminal Locations – KEB – (Inductions Only)

Connect the encoder cable wiring to the X3A terminal block on the encoder card mounted on the drive. The following table contains wiring references for common encoders.

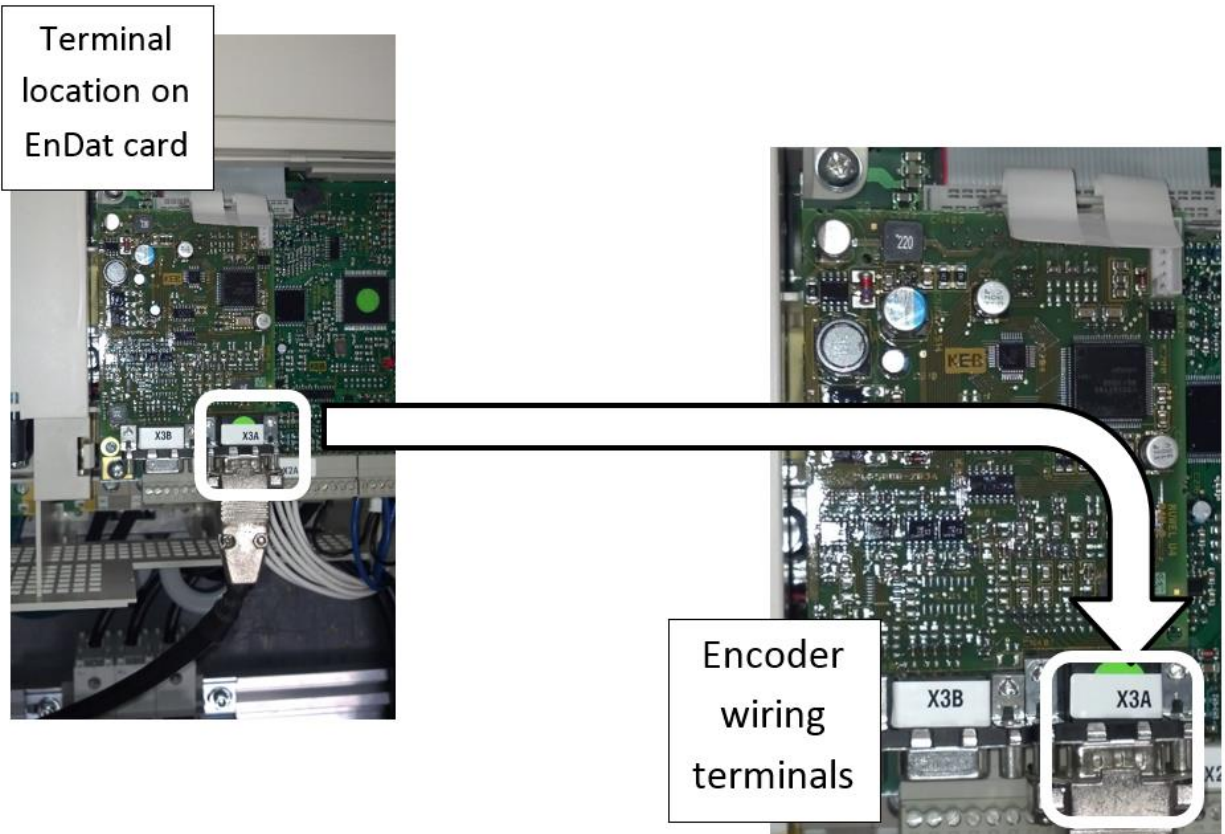
ENCODER	IMPERIAL 35' CABLE 0850357	IMPERIAL 50'/75' CABLE 0850489/490	MAGIL	ACCUCODER	WACHENDORFF	INDUSTRIAL ENCODER (CANADA)
PWR	RED	WHITE	RED	BROWN	BROWN	BROWN
COM	BLACK	BLACK	BLACK	BLUE	WHITE (SHIELD)	WHITE
A	WHITE	PURPLE	WHITE	WHITE	GREEN	GREEN
/A	BLACK/WHITE	GRAY	BROWN	GREEN	RED	PINK
B	BLUE	GREEN	GREEN	YELLOW	YELLOW	YELLOW
/B	RED/BLACK	BLUE	BLUE	GRAY	BLACK	BLUE
Z	ORANGE	-	YELLOW	PINK	GRAY	GRAY
/Z	GREEN	-	ORANGE	RED	VIOLET	RED
DATA	-	-	-	-	-	-
/DATA	-	-	-	-	-	-
CLOCK	-	-	-	-	-	-
/CLOCK	-	-	-	-	-	-
SHIELD	SHIELD	SHIELD	SHIELD	SHIELD	SHIELD	



## Encoder Terminal Locations – KEB – (PMs Only)

Connect the encoder cable serial plug to the X3A terminal serial plug on the EnDat card mounted on the drive. The following table contains wiring references for common encoders.

Encoder	Drive	Hollister Whitney	Heidenhain	Torin ecn413	Zeihl
PWR	IP	Brown	Green/Blue + Brown	Red/Pink	Gray/Green
COM	IG	White	Green/White + White	Black + Red/White	Pink/Yellow
A	A+	Green	Green/Black	Green + Black	Gray/Pink
/A	A-	Yellow	Yellow/Black	Yellow + Black	Red/Blue
B	B+	Blue	Blue/Black	Blue + Black	Blue
/B	B-	Red	Red/Black	Red + Black	Red
Z	-	-	-	-	-
/Z	-	-	-	-	-
CLK+	CK	Black	Gray	Gray	White
CLK-	$\overline{CK}$	Violet	Pink	Clear OR silver	Brown
DAT+	DT	Gray	Violet	Purple	Violet
DAT-	$\overline{DT}$	Pink	Yellow	White	Black
SHIELD	FE	Shield	Shield	Large Red	Shield





# MAGNETEK HPV900-S2 DRIVE

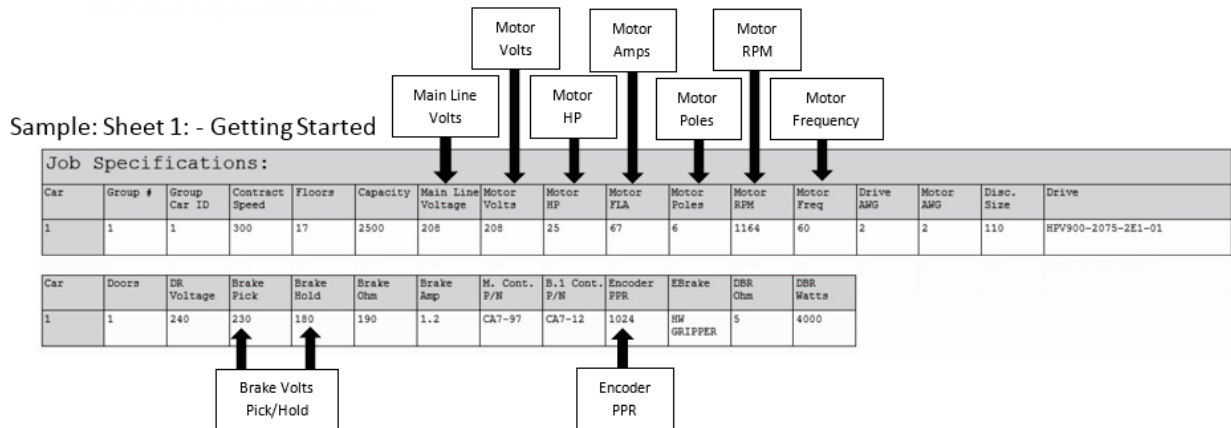
## INDUCTION MOTOR SETUP



## Equipment/Settings verification

Verify that the Job Specification parameter table on the drawings “Sheet 1: Getting Started” matches the actual equipment.

Below is a sample table showing the important values that will affect operation.



## Magnetek Parameter location Reference

ADJUST A0

### DRIVE A1

Encoder Pulses (Encoder PPR – 1024/2048)

### POWER CONVERT – A4

Input L-L Volts

### MOTOR – A5

Rated Mtr Power (Kw)

Rated Mtr Volts (VAC)

Rated Exit Freq (60Hz)

Rated Motor Curr (FLA – Amps)

Motor Poles

Rated Mtr Speed (RPM)

CONFIGURE C0

### USER SWITCHES – C1

Motor Rotation

- Forward/Reverse

Encoder Connect

- Forward/Reverse

## Operation

### (Check off box when complete)

Run the car and verify the following:

### No Faults

- Make sure the car is moving without triggering a fault either on the Smartrise SRU or the drive. If the SRU board displays a “Drive Fault” on the SRU, look at the drive to see what the fault is. The most common fault is “Encoder Flt”.
  - Go to “**Troubleshooting – Drive Fault / Encoder Flt**” for corrective actions.

### Proper Direction

- Make sure the car is moving in the same direction as the control switch on the Run Bug.
  - Go to “**Troubleshooting – Wrong Direction**” for corrective actions.

### At Speed

- Make sure that the car is moving at the proper inspection speed (approx. 50 FPM).
  - Go to “**Troubleshooting – Car Moving Too Slow or Rough**” for corrective actions.

### Under Control

- Make sure that the car is moving under full control. The car should stop when commanded from the Run Bug. Verify that the car runs with no faults for 10 seconds or more.
  - Go to “**Troubleshooting – Brake Not Lifting**” for corrective actions.

## Troubleshooting

### Drive Fault / Encoder Flt

- The most common fault at startup with a Magnetek drive is the Encoder fault. Perform the following checks to correct this fault:
  - a. Check for a solid *shield-to-ground* connection at the motor and drive.
  - b. Check for correct colored encoder wires to the terminals.
  - c. Swap A+ / A- on terminal TB1 – #1 (A+) and #2 (A-).
    - i. After swapping the A signal wires it may be necessary to change the direction of the “C1 – Encoder Connect”.

### Brake not lifting

1. If the brake is not picking make sure that it is wired according to “Sheet 5 – Brake & Hydro Options” and verify that the EB terminal is jumped to the terminal listed on “Sheet 01 – Getting Started”. If it has the proper voltage check the following:
  - a. During a run command, check for DC voltage between points K1 and K2. Verify this voltage is also at the Brake Coil when commanded to pick.
  - b. Verify the actual brake voltage matches the Brake Coil voltage setting shown on “Sheet 1: Getting Started” table.

### Wrong Direction

- If the car is moving in the wrong direction:
  - a. On the Smartrise controller board make sure that IO 521 comes on when commanding the **UP** direction and IO 522 comes on when commanding the **DOWN** direction.
  - b. Swap two of the motor leads (T1 with T2).

### Car moving too slow or rough

- Swap A+ / A- on terminal TB1 – #1 (A+) and #2 (A-).
  - a. After swapping the A signal wires it may be necessary to change the direction of the “C1 – Encoder Connect”.
- Verify the brakes are lifting fully.

## SETUP FAULT ONE

This is caused when the HPV900 is programmed with motor data (A5) that conflicts with the drive software.

1. Unplug the CAT5 cable from the DRIVE port on the machine room SRU board. This will restore access to the HPV LCD screen.
2. Go to A5 – Motor Parameters – Motor Poles and verify that you have the correct number of poles listed.
3. Next, go to A5 – Motor Parameters – Rated Motor Speed and lower the RPM 15-20 rpms and save.
4. Plug the CAT5 cable back into the DRIVE port on the machine room SRU.

### **Speed Adjustment on Magnetek (CMD vs. FPM)**

1. Make sure all your motor data is entered correctly.
2. On the Magnetek drive adjust this parameter:
  - a. Motor Drive (A1) “Contract Mtr Spd”
    - i. Adjust this up or down to match CMD speed to FPM actual speed.
    - ii. This does not have to match your motor’s actual RPM.

# MAGNETEK HPV900-S2 DRIVE

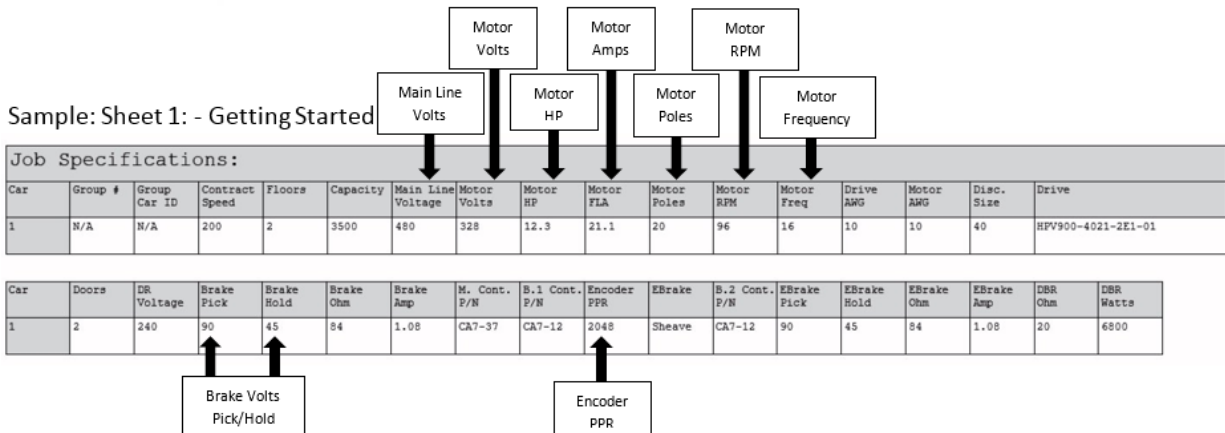
## PERMANENT MAGNET SETUP



## Equipment/Settings verification

Verify that the Job Specification parameter table on the drawings “Sheet 1: Getting Started” matches the actual equipment.

Below is a sample table showing the important values that will affect operation.



## MAGNETEK PARAMETER LOCATION REFERENCE

### ADJUST A0

#### DRIVE A1

Encoder Pulses (Encoder PPR – 1024/2048)

#### POWER CONVERT – A4

Input L-L Volts

#### MOTOR – A5

Rated Mtr Power (Kw)

Rated Mtr Volts (VAC)

Rated Exit Freq (60Hz)

Rated Motor Curr (FLA – Amps)

Motor Poles

Rated Mtr Speed (RPM)

### CONFIGURE C0

#### USER SWITCHES – C1

Motor Rotation

Forward/Reverse

Encoder Connect

Forward/Reverse

## Auto Tuning

The auto tune function must be performed for a PM motor to properly operate. The two functions are Encoder Alignment and Motor Alignment.

\*\* During the alignment process the Smartrise SRU board may display several faults. These are normal and won't affect the alignment procedure. \*\*

## Motor Alignment

(Check off box when complete)

- Use the Left|Right arrow buttons to select the “**AUTOTUNE SEL U12**” menu and then use the Up|Down arrow buttons to change **AUTOTUNE SELECT** to “**YES**” but **DON'T PRESS THE ENTER BUTTON YET!**
- Press and hold the M contactor button in.
- Press the Enter button on the drive to start the alignment.

## Encoder Alignment (non-rotational)

(Check off box when complete)

- On the drive: in the ROTOR ALIGN U10 menu change the following parameters:
  - ALIGNMENT METHOD to either “*HF Inject*” or “*AUTO ALIGN*” and press Enter (**see note on next page under Drive Info U6 table**).
  - ALIGNMENT from DISABLED to *ENABLE*.
  - BEGIN ALIGNMENT to “**YES**” but **DON'T PRESS THE ENTER BUTTON** yet!
- Press in and hold the M contactor button.
- Press the Enter Button on the drive to start the alignment.

If the drive displays the error message “**CAN NOT CHANGE AT THIS TIME**” make sure U10 ROTOR ALIGN – ALIGNMENT is set to *ENABLE*.



If there are other faults during this process, refer to the fault section of the Magnetek technical manual for diagnostic information.

## HPV900S2 DRIVE MENU TABLE

### BASICS U9

Parameter	Description	Choices
Drive Mode	Drive Operation	open loop Closed Loop PM

### AUTOTUNE SEL U12

Parameter	Description	Choices
Autotune Select	Allow autotune to run	disable on run yes

### ROTOR ALIGN U10

Parameter	Description	Choices
Alignment	Allow alignment to be performed	enable disable
Begin Alignment	Determine when to perform alignment	yes on run no
Alignment Method	How alignment will be performed	open loop auto align hf Inject [see note]

**NOTE:** "HF Inject" only works if the drive version is A4810-xxxx**15**.xx or above. Go to U6 DRIVE INFO and check the drive version. If the drive is not version "15" or above then use "AUTO ALIGN":

### DRIVE INFO U6

Parameter	Description	Choices
Drive VERSION	SHOWS THE SOFTWARE VERSION OF THE DRIVE SOFTWARE	A4810-xxxx <b>15</b> .xx

## Operation

### (Check off box when complete)

Run the car and verify the following:

### No Faults

- Make sure the car is moving without triggering a fault either on the Smartrise SRU or the drive. If the SRU board displays a “Drive Fault” on the SRU, look at the drive to see what the fault is. The most common fault is “Encoder Flt”.
  - Go to “***Troubleshooting – Drive Fault / Encoder Flt***” for corrective actions.

### Proper Direction

- Make sure the car is moving in the same direction as the control switch on the Run Bug.
  - Go to “***Troubleshooting – Wrong Direction***” for corrective actions.

### At Speed

- Make sure that the car is moving at the proper inspection speed (approx. 50 FPM).
  - Go to “***Troubleshooting – Car Moving Too Slow or Rough***” for corrective actions.

### Under Control

- Make sure that the car is moving under full control. The car should stop when commanded from the Run Bug. Verify that the car runs with no faults for 10 seconds or more.
  - Go to “***Troubleshooting – Brake Not Lifting***” for corrective actions.

## Troubleshooting

### Drive Fault / Encoder Flt

1. The most common fault at startup with a Magnetek drive is the Encoder fault. Perform the following checks to correct this fault:
  - a. Check for a solid *shield-to-ground* connection at the motor and drive.
  - b. Check for correct colored encoder wires to the terminals.
  - c. Verify that “C1 - Encoder Select” is set to “**endat**”.
  - d. Swap A+ / A- on terminal TB2 – #1 (A+) and #2 (A-).
    - i. After swapping the A signal wires it may be necessary to change the direction of the “C1 – Encoder Connect”.
    - ii. After changing any encoder wiring the Encoder Alignment should be ran again (See page 6).

### Brake not lifting

1. If the brake is not picking make sure that it is wired according to Sheet 5 – Brakes and verify that the EB terminal is jumped to the terminal listed on “Sheet 01 – Getting Started”. If it has the proper voltage check the following:
  - a. During a run command, check for DC voltage between points K1 / K2 and J1 / J2 (if 2<sup>nd</sup> brake installed). Verify the voltages are also at the Brake Coil(s) when commanded to pick.
  - b. Verify that the voltages match the Brake Coil voltages shown on “Sheet 1: Getting Started” table.

### Wrong Direction

1. If the car is moving in the wrong direction:
  - a. On the Smartrise controller board make sure that IO 521 comes on when commanding the **UP** direction and IO 522 comes on when commanding the **DOWN** direction.
  - b. Change the direction of the motor in the drive by going to “C1 – Motor Rotation” and toggling between FORWARD/ REVERSE.
  - c. Swap two of the motor leads (T1 with T2). After swapping the motor wires it may be necessary to change C1 – Motor Rotation again.

## **Car moving too slow or rough**

1. Swap the encoder wires A+ and A- on drive TB2 (terminals 1 & 2).
2. Verify the brakes are lifting fully.

## **SETUP FAULT ONE**

This is caused when the HPV is programmed with motor data (A5) that conflicts with drive software.

1. Unplug the CAT5 cable from the DRIVE port on the machine room SRU board. This will restore access to the HPV LCD screen.
2. Go to A5 – Motor Parameters – Motor Poles and verify that you have the correct number of poles listed.
3. Next, go to A5 – Motor Parameters – Rated Motor Speed and lower the RPM 15-20 rpms and save.
4. Plug the CAT5 cable back into the DRIVE port on the SRU.

## **Speed Adjustment on Magnetek (CMD vs. FPM)**

1. Make sure all your motor data is entered correctly.
2. On the Magnetek drive adjust this parameter:
  - a. Motor Drive (A1) “Contract Mtr Spd”
    - i. Adjust this up or down to match CMD speed to FPM actual speed.

This does not have to match your motor’s actual RPM.

# KEB DRIVE

## INDUCTION MOTOR SETUP



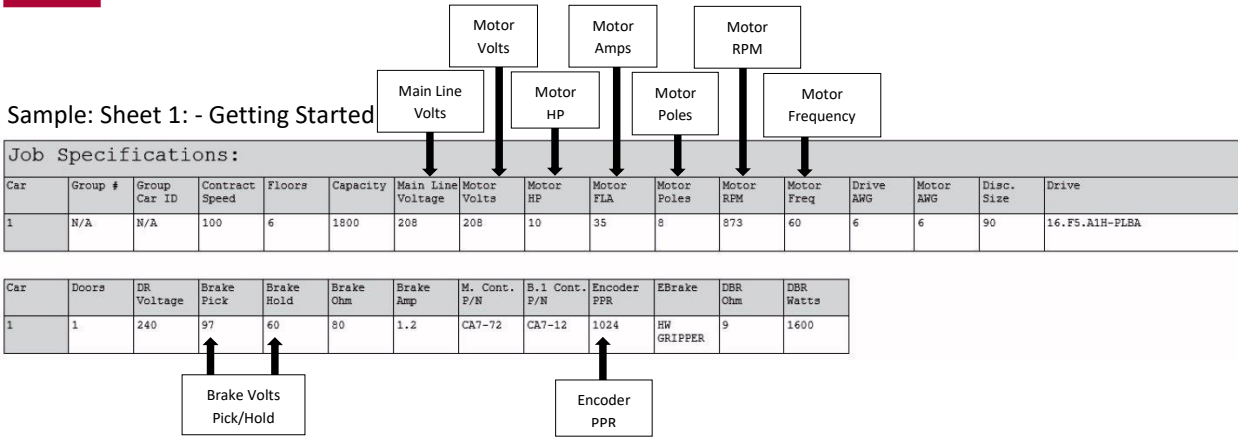
# KEB Introduction

## EQUIPMENT/SETTINGS VERIFICATION

Verify that the Job Specification parameter table on the drawings “Sheet 1: Getting Started” matches the actual equipment. Below is a sample table showing the important values that will affect operation.



Scroll through the motor parameters and verify that they are set to the motor nameplate values prior to performing the Motor Learn procedure.



# KEB Motor Learn

---

NOTE: Smartrise programs the KEB drive with factory defaults to properly communicate with the controller. After factory testing, customer motor data (from customer's EDF) is programmed into the drive to provide an easier "out of box" installation.

## Initial Start Up

The complete motor data must be learned with the automated learn function.

The Motor Learn function can be found under the Tune Parameters group from the Programming menu (*Home > Prog > Tune Parameters > LL01*).

Begin the procedure by setting:

- Motor Tuning LL01 = Start

Follow the instructions on the LCD screen. The user is instructed to:

1. Disable the brake (turn off the BR and EBR breaker).
2. Set command to zero on the MR SRU board under MAIN MENU | SETUP | SPEED AND SLOWDOWNS | INSPECTION SPEED – set to "0".
3. On the controller press and hold inspection (speed + direction + enable inputs) until completed.

The process should take 2-5 minutes and will emit a high pitched noise while the drive measures various motor parameters.



If not performing the Encoder Synchronization, turn on BR and EBR breakers and return the inspection speed to factory setting on the controller.

**SETUP OF THE MOTOR LEARN IS NOW COMPLETE!**

# KEB Encoder Learn

---

## 1. Encoder Synchronization

The Encoder Synchronization process will determine the correct A/B encoder channel phasing and direction of rotation for Induction motors.

Begin the process by setting:

- LL07 - Encoder Synchronization to “Start”

Follow the directions on the keypad. The drive will run the elevator and swap the phasing and direction of the A/B channels as needed.



Turn on the BR and EBR breakers and return the inspection speed to factory setting on the controller.

**SETUP OF THE ENCODER LEARN IS NOW COMPLETE!**



## OPERATION

(Check off box when complete)

Run the car and verify the following:

### No Faults

- Make sure the car is moving without triggering a fault either on the Smartrise SRU or the drive. If the SRU board displays a “Drive Fault” on the SRU, look at the drive to see what the fault is.
  - Go to “*Troubleshooting – Drive Fault / Encoder Flt*” for corrective actions.

### Proper Direction

- Make sure the car is moving in the same direction as the control switch on the Run Bug.
  - Go to “*Troubleshooting – Wrong Direction*” for corrective actions.

### At Speed

- Make sure that the car is moving at the proper inspection speed (approx. 50 FPM).
  - Go to “*Troubleshooting – Car Moving Too Slow or Rough*” for corrective actions.

### Under Control

- Make sure that the car is moving under full control. The car should stop when commanded from the Run Bug. Verify that the car runs with no faults for 10 seconds or more.
  - Go to “*Troubleshooting – Brake Not Lifting*” for corrective actions.

## TROUBLESHOOTING

### DRIVE FAULT / ENCODER FLT

- The most common fault at startup with drive startup is the Encoder fault.
  - a. Check for a solid *shield-to-ground* connection at the motor and drive.
  - b. Check for correct colored encoder wires to the terminals.
  - c. Swap the wires on A with A/ or swap A & A/ with B & B/.
  - d. Perform the “Encoder Synchronization” process after swapping any encoder wires.

### BRAKE NOT LIFTING

- If the brake is not picking make sure that it is wired according to Sheet 5 – Brakes, the EB terminal has power and then check the following:
  - a. During a run command, check for DC voltage between points K1 / K2 and J1 / J2 (if 2<sup>nd</sup> brake installed). Verify the voltages are also at the Brake Coil(s) when commanded to pick.
  - b. Verify that the voltages match the Brake Coil voltages shown on “Sheet 1: Getting Started” table.

### WRONG DIRECTION

- If the car is moving in the wrong direction:
  - a. On the Smartrise controller board make sure that IO 521 comes on when commanding the UP direction and IO 522 comes on when commanding the DOWN direction.
  - b. Swap two of the motor leads (T1 with T2).

### CAR MOVING TOO SLOW OR ROUGH

- Swap the encoder wires A+ and A- on drive.
- Verify the brakes are lifting fully.

## KEB PROGRAMMING MENU

The programming menu is where all manual parameter adjustment is made and can be accessed at *Home > Prog (F3)*.

The Parameter menu contains the following groups:

Operator System: OS00...OS22

These parameters provide general information about the operator and drive hardware and software. Additionally, the operator password level is set here which allows for different access levels.

Basic Setup: US02...US06

These parameters provide the very basic information needed to configure the drive, including: motor type, control type, and contract speed.

Inputs: LI01...LI20

These parameters define the logic of the inputs and assign control functionality to the digital inputs.

Motor Data: LM01...LM33

These parameters define and display all relevant motor values and motor protection settings.

Encoder Data: LE01...LE36

These parameters define the settings and scalings of the drive encoders

Machine Data: LN01...LN05

These parameters define the machine data, including: sheave diameter, roping ratio, and rated load values.

Speed Profile: LS01...LS55

These parameters adjust the speed, acceleration, and jerk values across the elevator run profile.

Tune Parameters: LL01...LL17

These parameters contain the automatic tuning parameters. Here you can program the system inertia, motor data, and motor pole positions.

Control Setting: LC01...LC44

These parameters contain advanced adjustment parameters which affect the motor gains, system inertia gains, pre-torque, etc.

Timer Parameters: LT01...LT13

These parameters adjust brake and drive signaling timers.

Positioning Parameters: LP01...LP08

These parameters contain the adjustments needed for the drive

Special Functions: LX01...LX18

These parameters allow advanced adjustment of the drive and facilitate function tests of drive components.

Configuration Handling: CH01...CH03

These settings allow a user to save parameters and default to OEM settings.

Analog I/O: LA01...LA40

These parameters define and adjust the analog inputs and outputs.

Outputs: LO01...LO20

These parameters define the functionality of the relay and solid-state drive outputs.

## ADVANCED TROUBLESHOOTING

The following list of troubleshooting steps are to help with the startup and smooth running of the drive.

### STARTING OVER! (DEFAULTING DRIVE)

Sometimes parameters get changed (and forgotten) or certain functions that should work are not working for no apparent reason. In this case, starting over with factory defaults may solve these issues.

### DEFAULT DRIVE TO FACTORY SETTINGS:

1. Go to US.03 and load the opposite configuration of what is shown: (example: *PM Gearless* – load *Induction Geared* / for *PM Geared* load *Induction Gearless*) and save. After this value is saved, go back and load the correct type. This does a complete background default on the drive.
2. Go to US.03 and choose “Write Configuration to Drive”.

Defaulting the drive:
US.03: Choose opposite drive configuration (PM > Induction / Geared > Gearless)
US.05: Write Configuration to Drive
Reload the original drive configuration using the previous (2) steps

### RE-LOAD OEM VALUES (PROGRAMMED BY SMARTRISE):

1. Go to US.05 and choose “Restore OEM Defaults”.

Restoring Smartrise Defaults:
US.05: Restore OEM Defaults (To Reload Smartrise Settings)

### MOTOR NOISE / VIBRATION

1. Vibration:
  - a. Cut the KP (LC03, LC04) and KI (LC08, LC09) gains in half.
2. Noise:
  - a. Change LE.05 to 8 (PM)

### MOTOR NOT RUNNING WHEN GIVEN COMMAND:

1. Check LI.01: Needs to be NPN for the drive to receive signals from controller.
2. Verify that parameters LF.41 through LF.43 are set to correct values. Refer to parameter sheet located in job binder for correct values.

# KEB DRIVE

## PM MOTOR SETUP



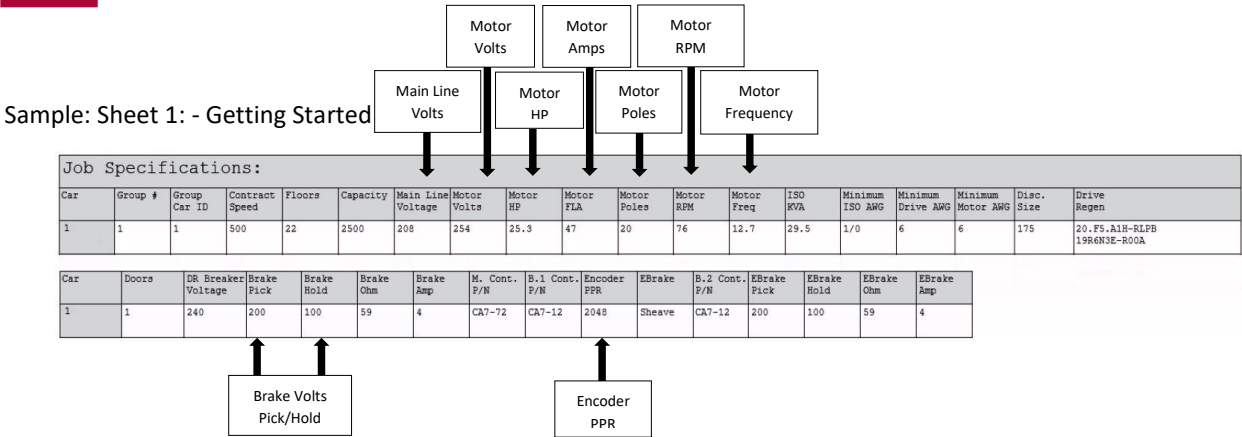
# KEB Introduction

## EQUIPMENT/SETTINGS VERIFICATION

Verify that the Job Specification parameter table on the drawings “Sheet 1: Getting Started” matches the actual equipment. Below is a sample table showing the important values that will affect operation.



Scroll through the motor parameters and verify that they are set to the motor nameplate values prior to performing the Motor Learn procedure.



## ENCODER CABLE INSTALLATION

Proper connection of the encoder cable to the drive is key to a proper running elevator. Many drive issues can be attributed to a defective encoder, encoder cable or the encoder (or cable) not installed properly.



The cable shall be kept a minimum of 8 inches (20 cm) away from all wires having greater than 24VDC on them. For best results run the encoder cable in a separate conduit from the controller to the motor.



It is absolutely necessary to ensure these signals are well shielded! Noise on the analog signals resulting from breaks in the shield or improper shield termination will result in vibration in the motor and poor ride quality.

# KEB Motor Learn

---

NOTE: Smartrise programs the KEB drive with factory defaults to properly communicate with the controller. After factory testing, customer motor data (from customer's EDF) is programmed into the drive to provide an easier "out of box" installation.

## Initial Start Up

The complete motor data must be learned with the automated learn function.

The Motor Learn function can be found under the Tune Parameters group from the Programming menu (*Home > Prog > Tune Parameters > LL01*).

Begin the procedure by setting:

- Motor Tuning LL01 = Start

Follow the instructions on the LCD screen. The user is instructed to:

1. Disable the brake (turn off the BR and EBR breaker).
2. Set command to zero on the MR SRU board under MAIN MENU | SETUP | SPEED AND SLOWDOWNS | INSPECTION SPEED – set to "0".
3. On the controller press and hold inspection (speed + direction + enable inputs) until completed.

The process should take 2-5 minutes and will emit a high pitched noise while the drive measures various motor parameters.



If not performing the Encoder Learn function, turn on BR and EBR breakers and return the inspection speed to factory setting on the controller.

**SETUP OF THE MOTOR LEARN IS NOW COMPLETE!**



# KEB Encoder Learn

---



For absolute encoders on PM motors, if at any time the physical relation between the motor shaft and encoder changes (i.e. encoder replaced, encoder slippage, etc.) the encoder position must be relearned.

## 1. SPI Encoder Learn - Stationary

SPI can be done with the ropes on and the brake set. To start the SPI functionality go to LL05 and follow the instructions on the LCD:

Begin the procedure by setting:

- Motor Tuning LL05 = SPI (Start)

Follow the instructions on the LCD screen. The user is instructed to:

1. Disable the brake (turn off the BR and EBR breaker).
2. Set command to zero on the MR SRU board under MAIN MENU | SETUP | SPEED AND SLOWDOWNS | INSPECTION SPEED – set to “0”.
3. On the controller press and hold the inspection (direction + enable button) until completed.

During the SPI process, the motor will make a series of chirps and the LCD display will show the encoder position samples.

Proceed to Section #3 “Encoder Synchronization” for further details.

If the Encoder Synchronization process has previously been completed, the user may abort the Encoder Synchronization step without losing the learned Encoder Pole Position.

## 2. Encoder Pole Position Learn – (Optional)

The Encoder Pole Position Learn is only used when the car is balanced or the ropes have not been installed as this procedure requires frictionless movement (un-rope sheave or balanced car). It sets the correct A/B channel phasing in addition to the pole position.

Begin the procedure by setting:

- LL06 - Encoder Pole Position Learn = Start

The user will be prompted to:

“Press and hold the inspection (direction + enable button) until finished.”  
The controller speed should still be at “0” FPM.

If the A/B phasing is incorrect the process will stop and notify the user. Then it will resume and automatically make the change and prompt the user to hold the inspection buttons again.

When the process is complete, the keypad will prompt the user to release the inspection buttons.

Proceed to Section #3 “Encoder Synchronization” for further details.

If the Encoder Synchronization process has previously been completed, the user may abort the Encoder Synchronization step without losing the learned Encoder Pole Position.

## 3. Encoder Synchronization

The Encoder Synchronization process will determine the correct A/B encoder channel phasing and direction of rotation for PM motors and immediately follows either method of learning the encoder pole position.

Begin the process by setting:

- LL07 - Encoder Synchronization to “Start”

Follow the directions on the keypad. The drive will run the elevator and swap the phasing and direction of the A/B channels as needed.



Turn on the BR and EBR breakers and return the inspection speed to factory setting on the controller.

**SETUP OF THE ENCODER LEARN IS NOW COMPLETE!**

## OPERATION

(Check off box when complete)

Run the car and verify the following:

### No Faults

- Make sure the car is moving without triggering a fault either on the Smartrise SRU or the drive. If the SRU board displays a “Drive Fault” on the SRU, look at the drive to see what the fault is.
  - Go to “*Troubleshooting – Drive Fault / Encoder Flt*” for corrective actions.

### Proper Direction

- Make sure the car is moving in the same direction as the control switch on the Run Bug.
  - Go to “*Troubleshooting – Wrong Direction*” for corrective actions.

### At Speed

- Make sure that the car is moving at the proper inspection speed (approx. 50 FPM).
  - Go to “*Troubleshooting – Car Moving Too Slow or Rough*” for corrective actions.

### Under Control

- Make sure that the car is moving under full control. The car should stop when commanded from the Run Bug. Verify that the car runs with no faults for 10 seconds or more.
  - Go to “*Troubleshooting – Brake Not Lifting*” for corrective actions.

## TROUBLESHOOTING

### DRIVE FAULT / ENCODER FLT

- The most common fault at startup with drive startup is the Encoder fault.
  - a. Check for a solid *shield-to-ground* connection at the motor and drive.
  - b. Check for correct colored encoder wires to the terminals.
  - c. Swap the wires on A with A/ or swap A & A/ with B & B/.
  - d. Perform the “Encoder Synchronization” process after swapping any encoder wires.

### BRAKE NOT LIFTING

- If the brake is not picking make sure that it is wired according to Sheet 5 – Brakes, the EB terminal has power and then check the following:
  - a. During a run command, check for DC voltage between points K1 / K2 and J1 / J2 (if 2<sup>nd</sup> brake installed). Verify the voltages are also at the Brake Coil(s) when commanded to pick.
  - b. Verify that the voltages match the Brake Coil voltages shown on “Sheet 1: Getting Started” table.

### WRONG DIRECTION

- If the car is moving in the wrong direction:
  - a. On the Smartrise controller board make sure that IO 521 comes on when commanding the UP direction and IO 522 comes on when commanding the DOWN direction.
  - b. Swap two of the motor leads (T1 with T2).

### CAR MOVING TOO SLOW OR ROUGH

- Swap the encoder wires A+ and A- on drive.
- Verify the brakes are lifting fully.

## KEB PROGRAMMING MENU

The programming menu is where all manual parameter adjustment is made and can be accessed at *Home > Prog (F3)*.

The Parameter menu contains the following groups:

Operator System: OS00...OS22

These parameters provide general information about the operator and drive hardware and software. Additionally, the operator password level is set here which allows for different access levels.

Basic Setup: US02...US06

These parameters provide the very basic information needed to configure the drive, including: motor type, control type, and contract speed.

Inputs: LI01...LI20

These parameters define the logic of the inputs and assign control functionality to the digital inputs.

Motor Data: LM01...LM33

These parameters define and display all relevant motor values and motor protection settings.

Encoder Data: LE01...LE36

These parameters define the settings and scalings of the drive encoders

Machine Data: LN01...LN05

These parameters define the machine data, including: sheave diameter, roping ratio, and rated load values.

Speed Profile: LS01...LS55

These parameters adjust the speed, acceleration, and jerk values across the elevator run profile.

Tune Parameters: LL01...LL17

These parameters contain the automatic tuning parameters. Here you can program the system inertia, motor data, and motor pole positions.

Control Setting: LC01...LC44

These parameters contain advanced adjustment parameters which affect the motor gains, system inertia gains, pre-torque, etc.

Timer Parameters: LT01...LT13

These parameters adjust brake and drive signaling timers.

Positioning Parameters: LP01...LP08

These parameters contain the adjustments needed for the drive

Special Functions: LX01...LX18

These parameters allow advanced adjustment of the drive and facilitate function tests of drive components.

Configuration Handling: CH01...CH03

These settings allow a user to save parameters and default to OEM settings.

Analog I/O: LA01...LA40

These parameters define and adjust the analog inputs and outputs.

Outputs: LO01...LO20

These parameters define the functionality of the relay and solid-state drive outputs.

## ADVANCED TROUBLESHOOTING

The following list of troubleshooting steps are to help with the startup and smooth running of the drive.

### STARTING OVER! (DEFAULTING DRIVE)

Sometimes parameters get changed (and forgotten) or certain functions that should work are not working for no apparent reason. In this case, starting over with factory defaults may solve these issues.

### DEFAULT DRIVE TO FACTORY SETTINGS:

1. Go to US.03 and load the opposite configuration of what is shown: (example: *PM Gearless* – load *Induction Geared* / for *PM Geared* load *Induction Gearless*) and save. After this value is saved, go back and load the correct type. This does a complete background default on the drive.
2. Go to US.03 and choose “Write Configuration to Drive”.

Defaulting the drive:
US.03: Choose opposite drive configuration (PM > Induction / Geared > Gearless)
US.05: Write Configuration to Drive
Reload the original drive configuration using the previous (2) steps

### RELOAD OEM VALUES (PROGRAMMED BY SMARTRISE):

1. Go to US.05 and choose “Restore OEM Defaults”.

Restoring Smartrise Defaults:
US.05: Restore OEM Defaults (To Reload Smartrise Settings)

### MOTOR NOISE / VIBRATION

1. Vibration:
  - a. Cut the KP (LC03, LC04) and KI (LC08, LC09) gains in half.
2. Noise:
  - a. Change LE.05 to 8 (PM)

### MOTOR NOT RUNNING WHEN GIVEN COMMAND:

1. Check LI.01: Needs to be NPN for the drive to receive signals from controller.
2. Verify that parameters LF.41 through LF.43 are set to correct values. Refer to parameter sheet located in job binder for correct values.

# BRAKE BOARD ADJUSTING & REPLACING PROCEDURE



# BRAKE BOARD REPLACEMENT

---

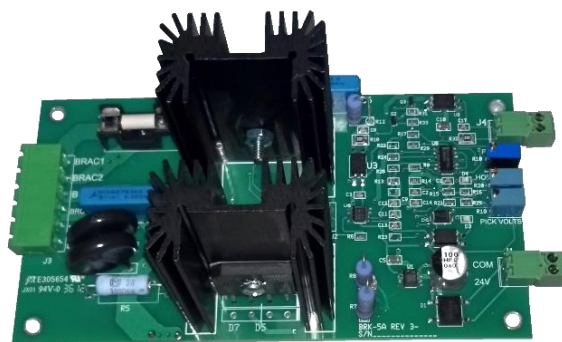
The Small Brake board is mounted on the rail directly below the Drive.

1. Turn off the controller main disconnect power.
2. With power removed, remove the 6-terminal plug on the brake board.
3. Remove the 4 screws attaching the brake board to the rail.
4. Install the new brake board on the rail and attach re-install the 4 screws.
5. Plug in the 6-pin connector on the brake board.



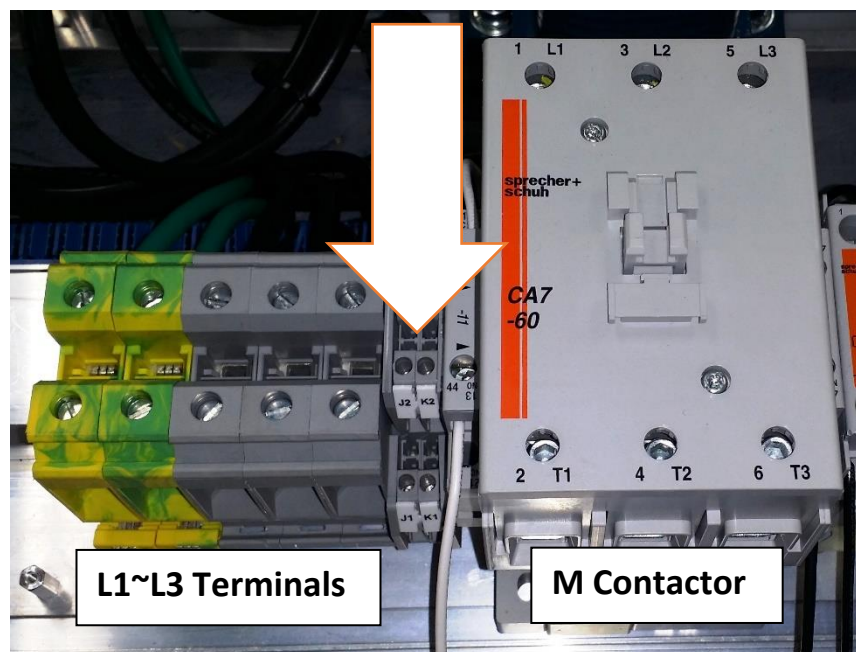
The Large Brake board is mounted on the rail directly below the Drive.

1. Turn off the controller main disconnect power.
2. With power removed, remove the 6-terminal and both 2-terminal plugs on the brake board.
3. Remove the 4 screws attaching the brake board to the rail.
4. Install the new brake board on the rail and attach re-install the 4 screws.
5. Plug in the 6-terminal and both 2-terminal plugs back on the brake board.



## BRAKE BOARD ADJUSTMENT

The adjustment procedure is the same for both the small and large brake boards. The brake coils **MUST** be connected to the terminals to provide a load when measuring voltages. The brake terminals are located between the M contactor and the L1~L3 main line terminals.

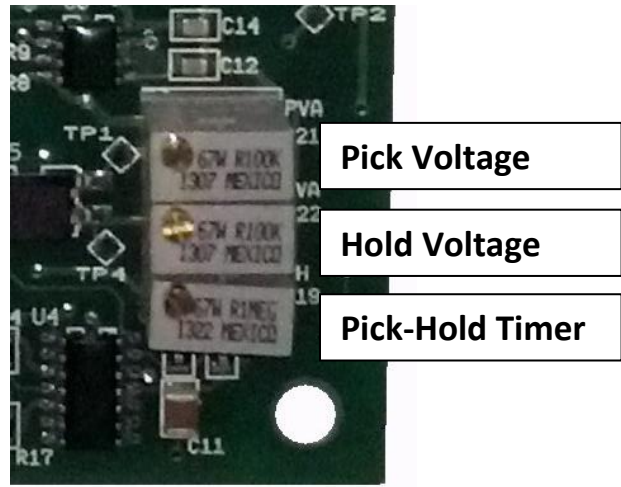


### Adjustment Pot Descriptions

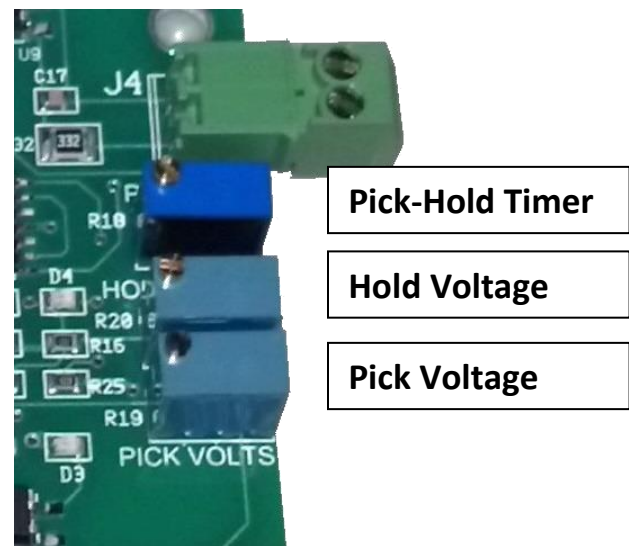
1. Pick Voltage
  - a. This pot adjusts the PICK voltage that the board initially sends out to the brake coil to pick the brake.
2. Hold Voltage
  - a. This pot adjusts the HOLD voltage that keeps the brake picked during running. This is usually lower than the Pick voltage.
3. Pick-Hold Timer
  - a. This is the adjustable delay between the time the PICK voltage activates and transitions to the HOLD voltage. This timer can be adjusted as high as 3.5 seconds.

The location of the adjustment potentiometers are shown on the next page:

## Small Brake Board Adjustment Pots



## Large Brake Board Adjustment Pots



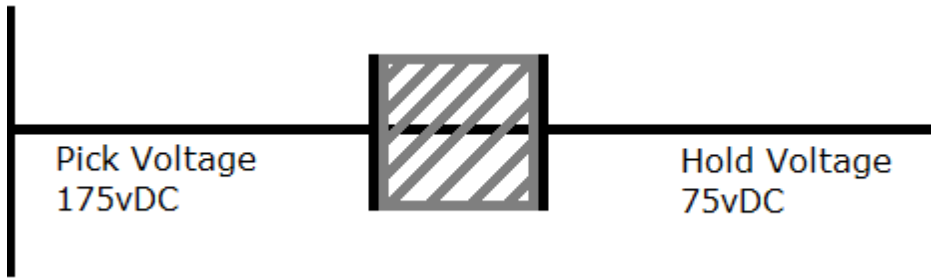
## Special Note when Adjusting Voltages:

The voltages between the PICK and HOLD levels are interconnected. Adjusting one will affect the other.

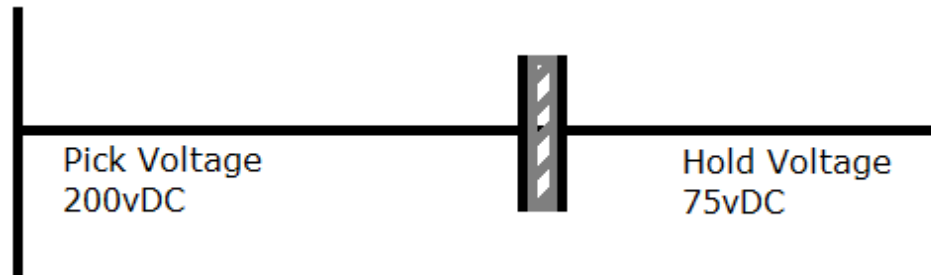
Adjust the PICK voltage to its maximum. If more voltage is required, lower the HOLD voltage down a little bit and readjust the PICK voltage.

Example:

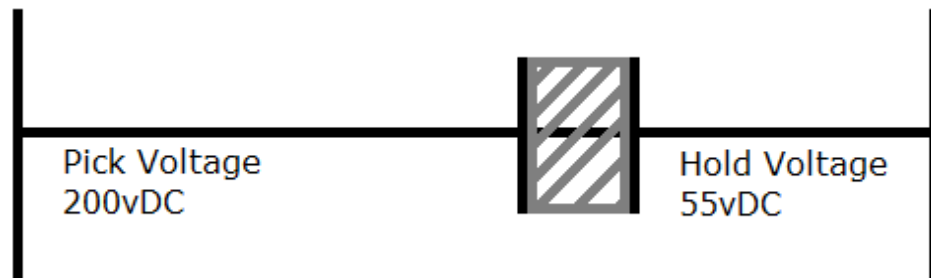
1. The PICK voltage is 175vDC and the HOLD voltage is 75vDC.



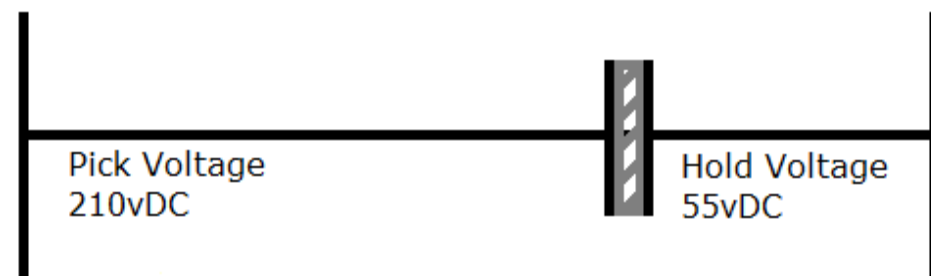
2. The PICK voltage is raised to 200vDC max while the HOLD voltage is still 75vDC.



3. The HOLD voltage is adjusted down to 55vDC.



4. The PICK voltage has more room for adjustment and can be raised to 210vDC.



## **Main Brake Adjustment**

These potentiometers are 30 turn pots. Only turning it a few times may seem like the pots are not working. This is normal and does not mean the brake board is faulty.

1. Make sure that the brake coil is connected to the K1/K2 terminals.
2. Connect a voltage meter to the K1 and K2 terminals.
3. Pick the brake so that there is voltage going to the brake coil.
4. Measure across K1 and K2 to see what the current voltage is.
5. Adjust the PICK voltage potentiometer to obtain the required voltage level.
6. Adjust the HOLD voltage potentiometer to obtain the required voltage level.
7. Adjust the PICK to HOLD timer potentiometer to obtain the required time difference between the PICK and HOLD voltage change.

## **Emergency Brake Adjustment (Dual Sheave Only)**

The adjustment for the e-brake on a Dual Sheave Motor is the same as the Main Brake adjustment with the following exceptions:

1. Make sure that the e-brake coil is connected to the J1/J2 terminals.
2. Measure across J1 and J2 to see what the voltage is.

# PROCEDURE ON SWAPPING THE CEDES INTERFACE BOARD

**NOTE:**

When replacing the CIB board with a brand-new replacement CIB board, it will require to relearn the hoistway.

**PROCEDURE:**

When replacing CIB boards please follow the steps below:

- 1) Put the car on machine room inspection.
- 2) Put the car on car top inspection.
- 3) Remove the cat 5s from the CIB board and green plug.
- 4) Plug in the cat 5s and green plug into the replacement CIB board.
- 5) Take it off car top inspection
- 6) Move the elevator down to the bottom landing in door zone on machine room inspection.
- 7) Turn on dip switch 2 on dip a, take it off inspection mode and onto normal mode.
- 8) Go to MAIN MENU | SETUP | LEARN MODE COMMANDS | LEARN MAGNETS.

Replacement is done.



# STEEL TAPE LANDING SYSTEM



# IP8300 SELECTOR, TAPE AND MAGNETS

---

IP8300 Selector - The IP8300 uses a CAT5 cable to connect the reader head to a breakout board with eight screw terminals. Guide shoes bring the tape through the reader head where sensors read the magnets.



Steel Tape - The IP8300 system uses a perforated steel tape that runs the length of the hoistway. Speed and direction is detected as the holes in the tape interrupt two light beams from the IP8300 selector.



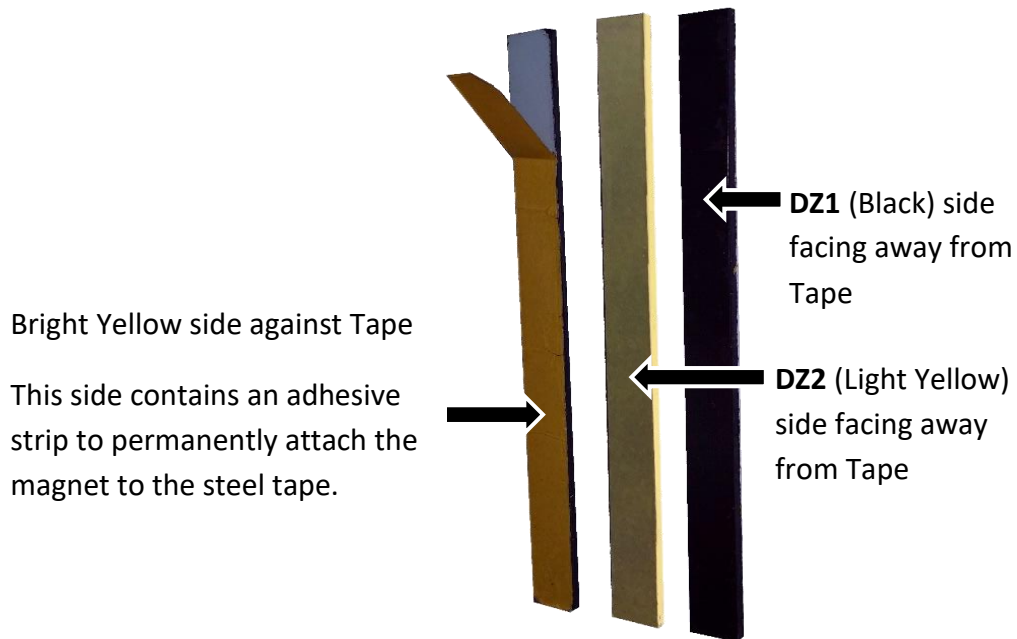
Tape Mounting Kit – The tape mounting kit contains the hardware to attach the steel tape to the top and bottom of the hoistway. The lower mounting bracket contains an adjustable spring to tighten the tape’s tension.



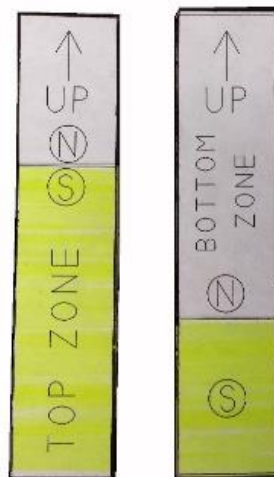
Magnets - Magnets are placed on the tape to mark door zones, UET, and DET positions.

Door Zone (DZ) – refers to the Door Zone magnet. Proper installation of the door zone magnets is very important for floor leveling and Normal Limits.

### 6' Door Zone Magnets



ETS (North/South) – The ETS magnets are a dual North/South combination that allows the IP8300 selector to determine which terminal landing it's at. The placement of the magnets is shown on the "UET/DET MAGNET INSTALLATION – DISTANCE FROM DOOR ZONE" illustration.



# TAPE AND SELECTOR SET UP

## Setup

Use Construction Mode to complete Hoistway set up (i.e. running the tape, placing magnets, setting up the Hall Network, etc.).

## Tape

Make sure the tape has the proper tension. Torque down the tension spring at end of the tape until tape has ½” to 1” full inch of play. Failing to torque down the tape may compromise the ability of the landing system to count the tape holes and cause premature wear on the selector guide shoes.

## Selector

Install the IP8300 Landing system on the Cartop so that the selector can move freely during travel.

Make sure to use a standard CAT5 cable and NOT a modified cable to connect the selector to the breakout board in the cartop box (SmartConnect only). *NOTE: Using a modified cable causes DP1 and DP2 to not toggle on and off.*

## Testing

If either DP1 (GEA) or DP2 (GEB) is constantly on while the other is flashing make sure that the IP8300 selector is aligned properly and not obstructed or that the governor encoder is not slipping on the governor shaft. Make sure all plates and covers are secure.

Verify that a positive FPM feedback is displayed on the LCD during an UP command. If the values are backwards (i.e., CMD = 50, FPM = – 50) swap the DP1 (GEA) and DP2 (GEB) on the Cartop Board (501/502).

# DOOR ZONE MAGNET INSTALLATION – TAPE

---

Refer to “*DZ1/DZ2 Magnet Placement Illustrations*” on the following pages.

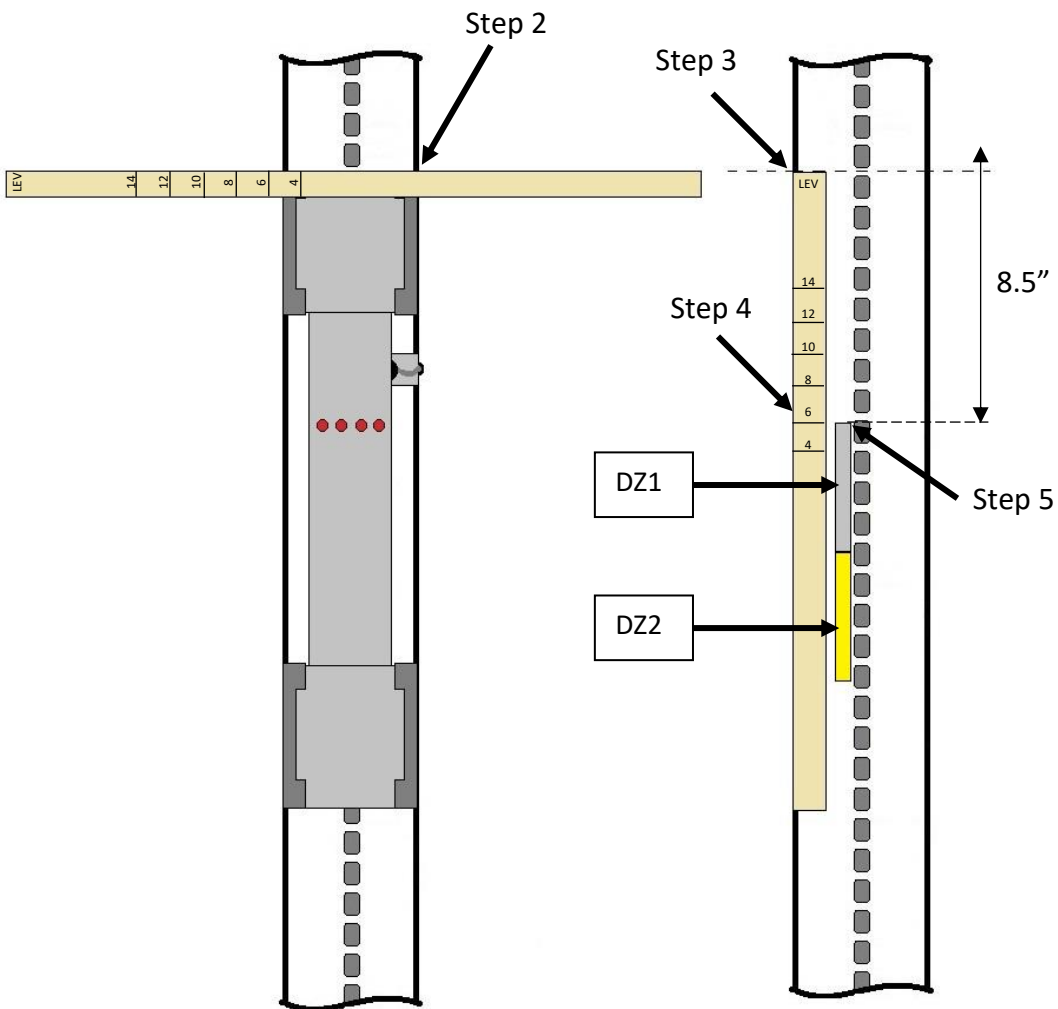
## Measuring magnet placement (using paper jig)

1. From the cartop, level the elevator to the Landing and then gain access to the tape.
2. Place the paper jig (packaged with IP8300 selector) across the top of the IP8300 tape selector guide rails. Mark a line on the steel tape at the top of the selector.
3. Move the car down to expose the tape enough to align the top of the paper jig with the scribed line.
4. Fold the paper jig around the steel tape with the numbered side facing out and the “LEV” marking at the top aligned with the mark you made in Step 2. Mark a line on the tape at the 6” mark on the paper jig.
5. Secure the 6” DZ1 magnet to the steel tape at the mark you made in Step 4 so that the magnet is slightly covering the holes.

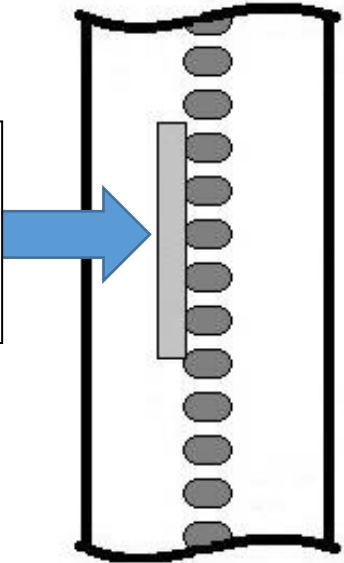
## Measuring magnet placement (No Jig)

1. From the cartop, level the elevator to the floor (Landing) to access the tape.
2. Place a mark on the tape along the top of the selector.
3. Move the car down until the top of the selector is at least 18” below the line you made in Step 2.
4. Put a mark 8.5” down from the line you made in Step 2.
5. Place the black 6” DZ1 magnet to the steel tape at the mark you made in Step 4.
6. Place the light yellow 6” DZ2 magnet below the DZ1 magnet based on the installation type (traction or hydro)

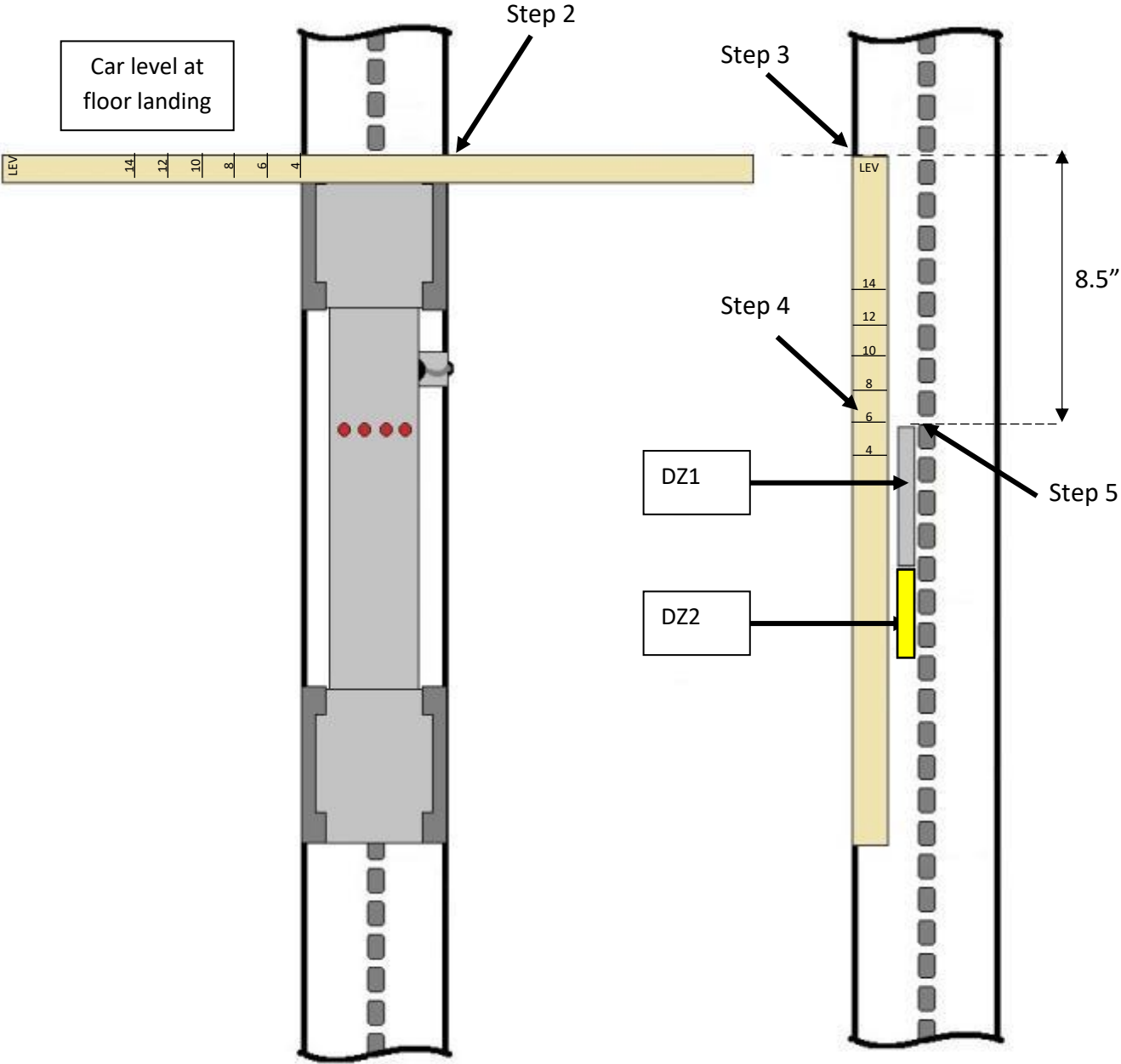
# TRACTION DZ1/DZ2 MAGNET PLACEMENT – ALL LANDINGS



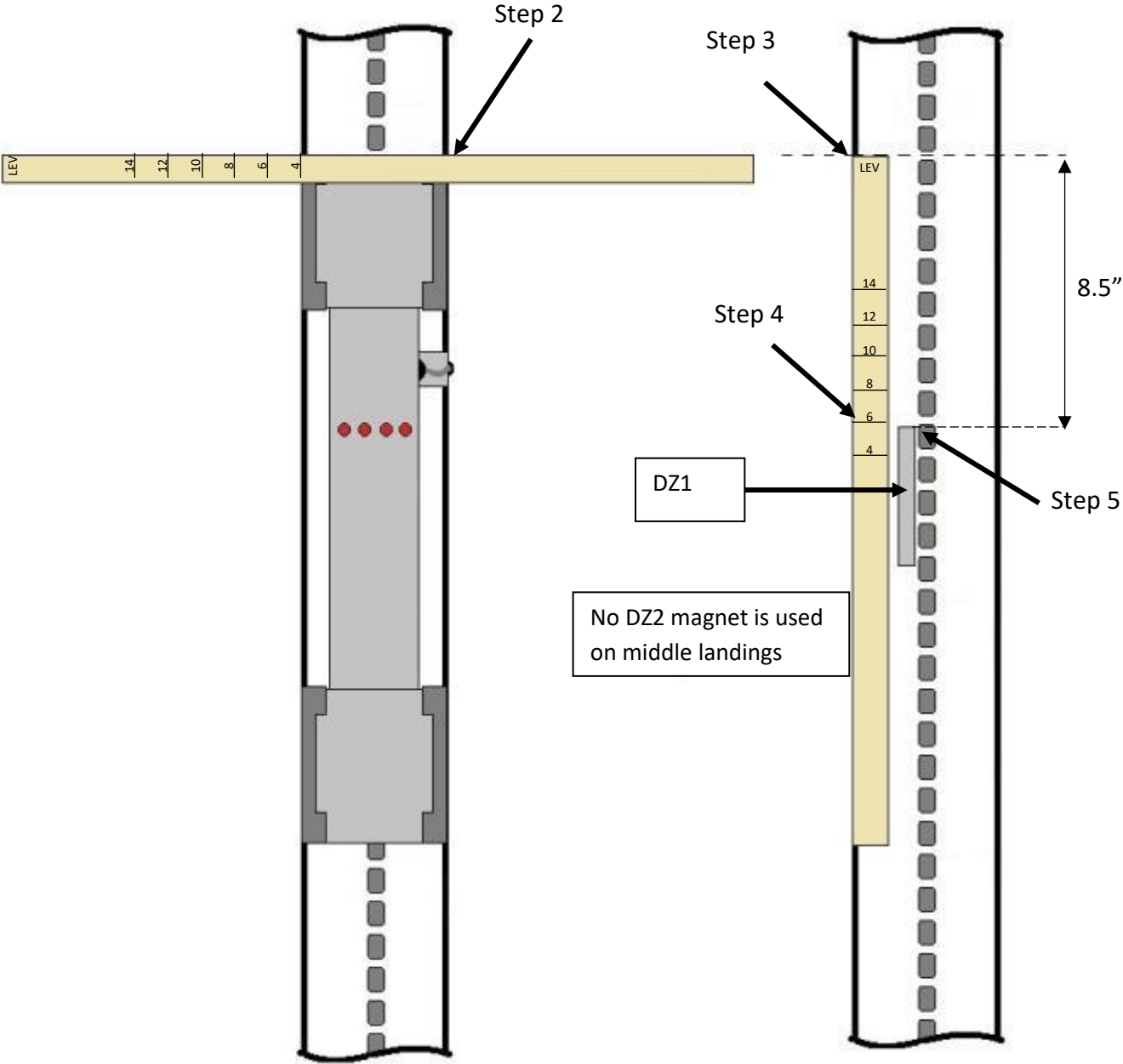
Set the DZ magnet on the left side of the tape holes. Place the paper jig on the tape and align the magnet against the jig.



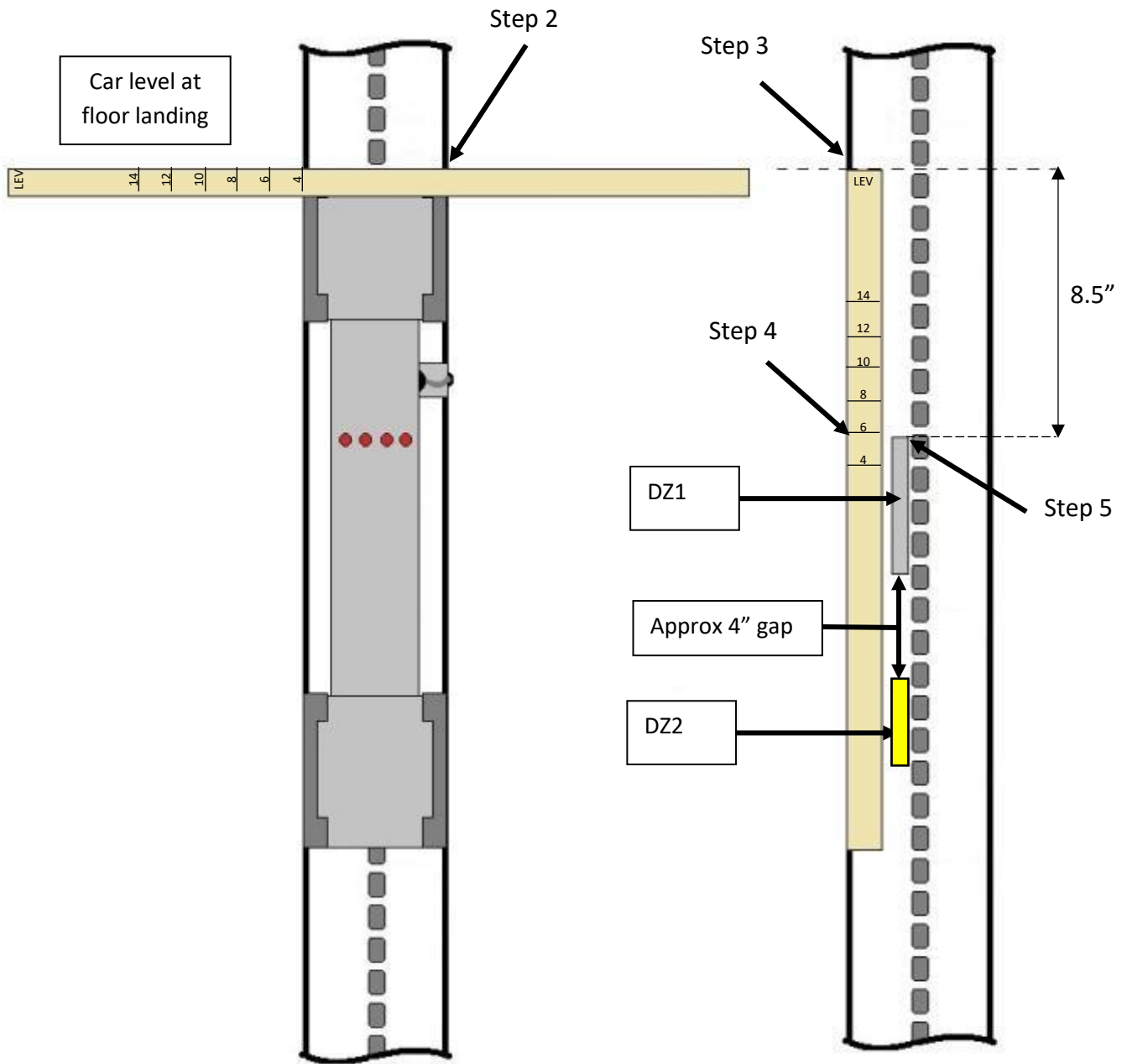
# HYDRO DZ1/DZ2 MAGNET PLACEMENT – TOP TERMINAL LANDING



# HYDRO DZ1/DZ2 MAGNET PLACEMENT – INTERMEDIATE LANDINGS



# HYDRO DZ1/DZ2 MAGNET PLACEMENT – BOTTOM TERMINAL LANDING



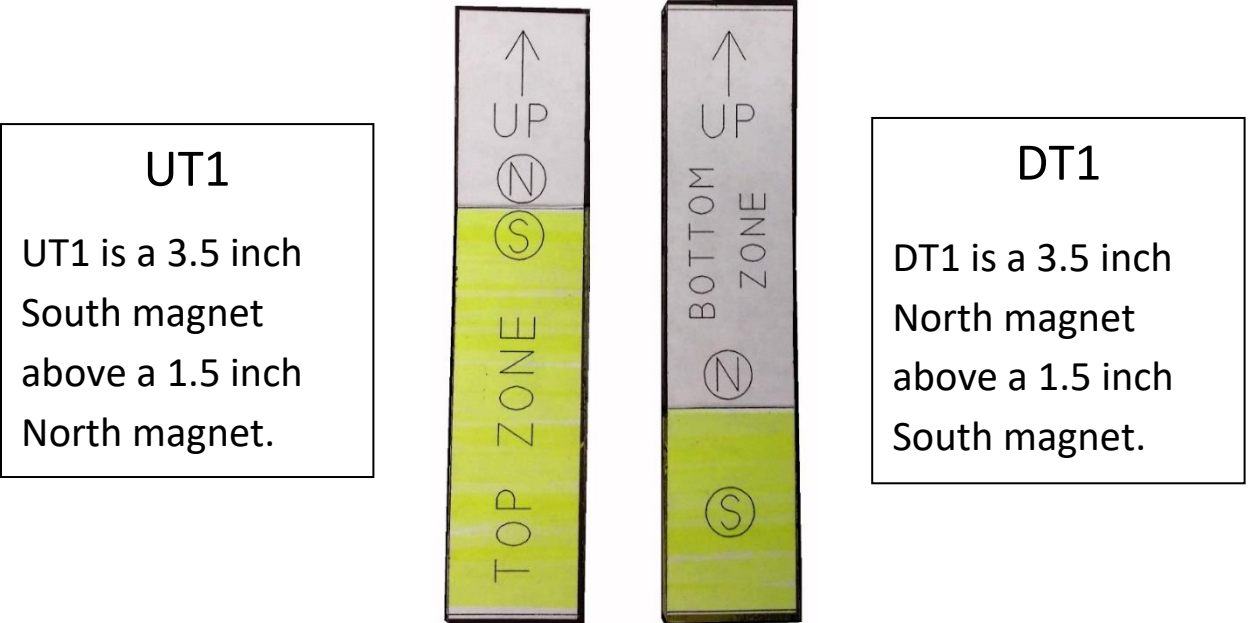


# UT1/DT1 MAGNET DESCRIPTION – TAPE

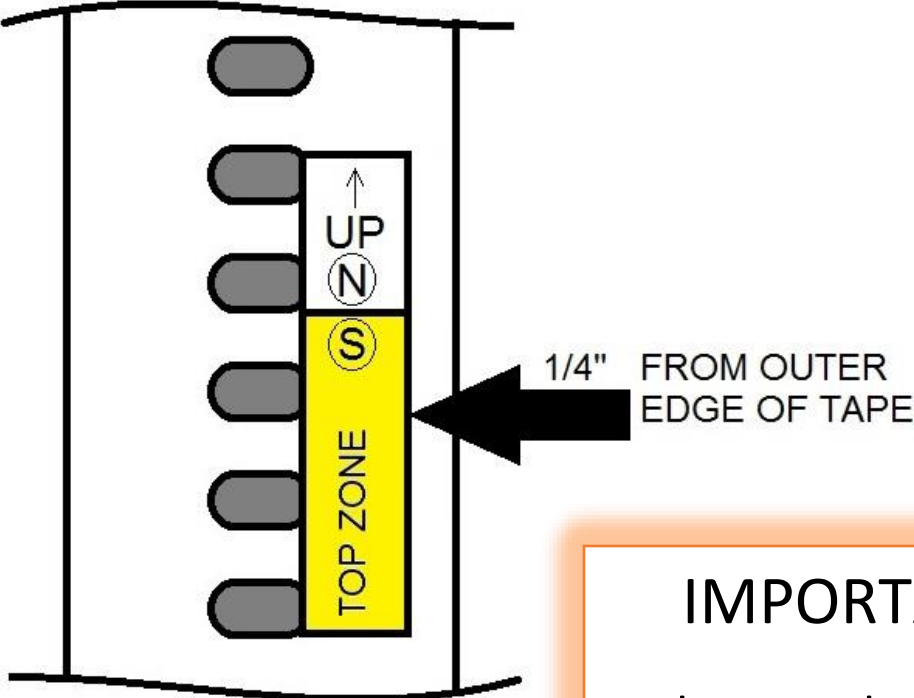
The Emergency Terminal Stopping magnets provide an indication that the car is near the top terminal (UET) or bottom terminal (DET).

Orientation of the North/South magnet is very important since this signal is driven by a relay within the selector as it passes over the magnet pairs.

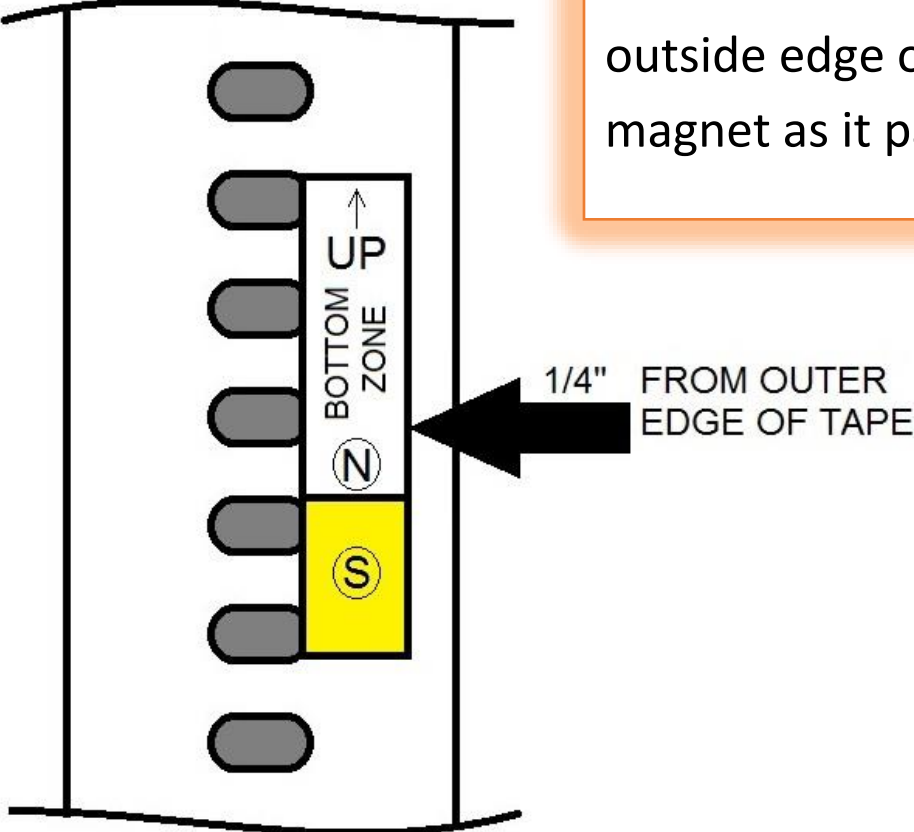
Improper orientation will cause the signals to not function properly and the car to fail the Learn Procedure.



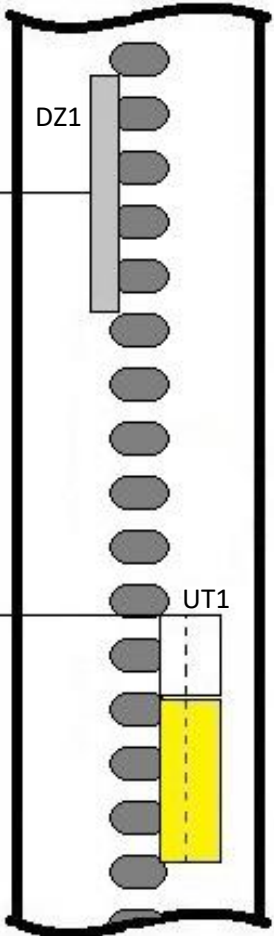
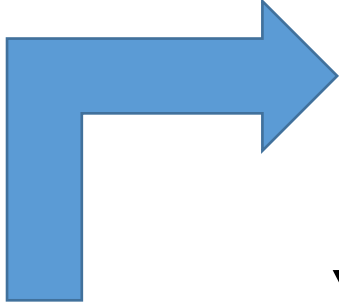
# UT1/DT1 MAGNET ALIGNMENT – TAPE



**IMPORTANT!**  
Make sure that the selector shoe clears the outside edge of the magnet as it passes by.

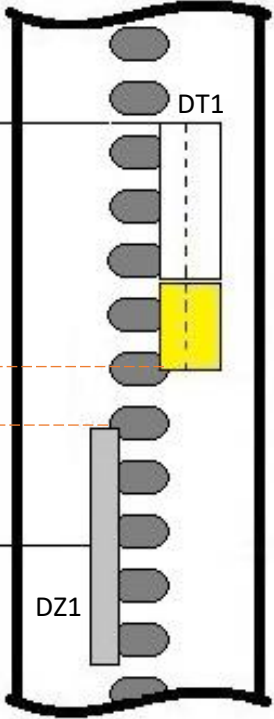
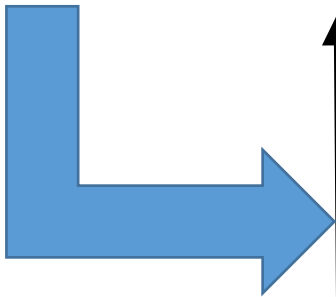


# UET/DET MAGNET PLACEMENT – TAPE



**Hydros/Low Speed Traction Cars** – Use the ETS Hoistway Switch Positioning Table on the next page for proper distance.

**High Speed Traction Cars** – Use the “Slide Distance – Determining ETS Magnet Placement” procedure for proper distance.

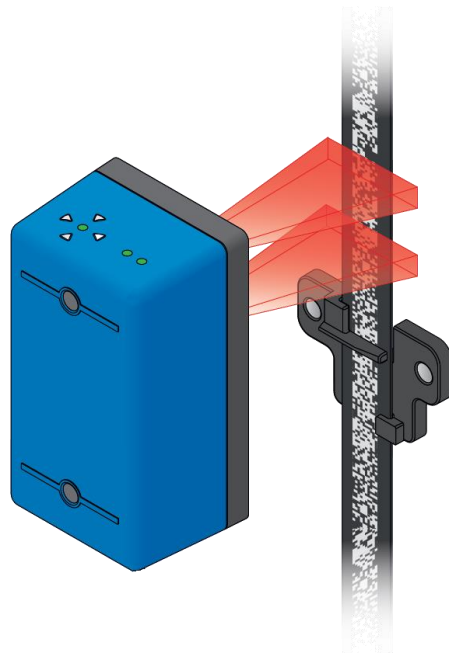


**HYDRO’S ONLY**

When installing the DT1 magnet: For low speed cars make sure the DT1 magnet has a min gap of 4” from bottom of DT1 magnet to Top of DZ Magnet.

# HOISTWAY SWITCH POSITIONING TABLE – NTS

Hoistway Switch Positioning Table			
Contract Speed	UT1 / DT1 [inches from terminal DZ]	UT2 / DT2 [inches from terminal DZ]	UT3 / DT3 [inches from terminal DZ]
10 - 50	5"		
51 - 75	7"		
76 - 100	9"		
100 - 125	11"		
126 - 150	13"		
151 - 175	15"		
176 - 200	17"		
201 - 250	21"		
251 - 300	27"		
301 - 350	33"		
351 - 400	39"		
401 - 450	45"		
451 - 500	51"		



# CEDES APS System Landing System

<http://www.smartrise.us/support/training-videos/>

## 1.0 PURPOSE

**This quick start manual is to be used as a supplemental document to expedite installation of the CEDES Absolute Positioning System (APS). Please use caution and read full manuals for thorough descriptions and specifications. This document will guide a step by step installation in subsequent order. Please follow along closely and the installation will go smoothly.**

## 2.0 SCOPE

**Included in this manual is a brief installation process of the CEDES APS Landing System. Precautions, general safety, proper installation, hardware and components are all discussed. Basic SRU configuration, learn procedure and troubleshooting is also discussed. Please refer to the supplemental CEDES and Smartrise Engineering manuals accompanied in the package for further information, Thank you.**

# 3.0 SYSTEM OVERVIEW

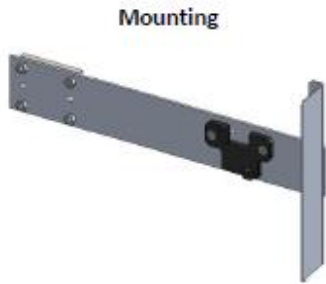


Figure 1: Tape Clip Assembly

TAPE



Figure 3: Tape

Camera Assembly

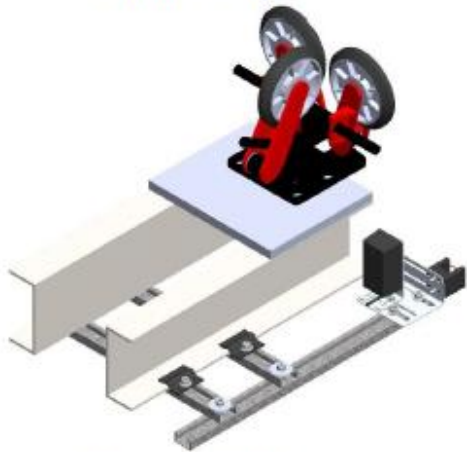


Figure 2: Camera Assembly

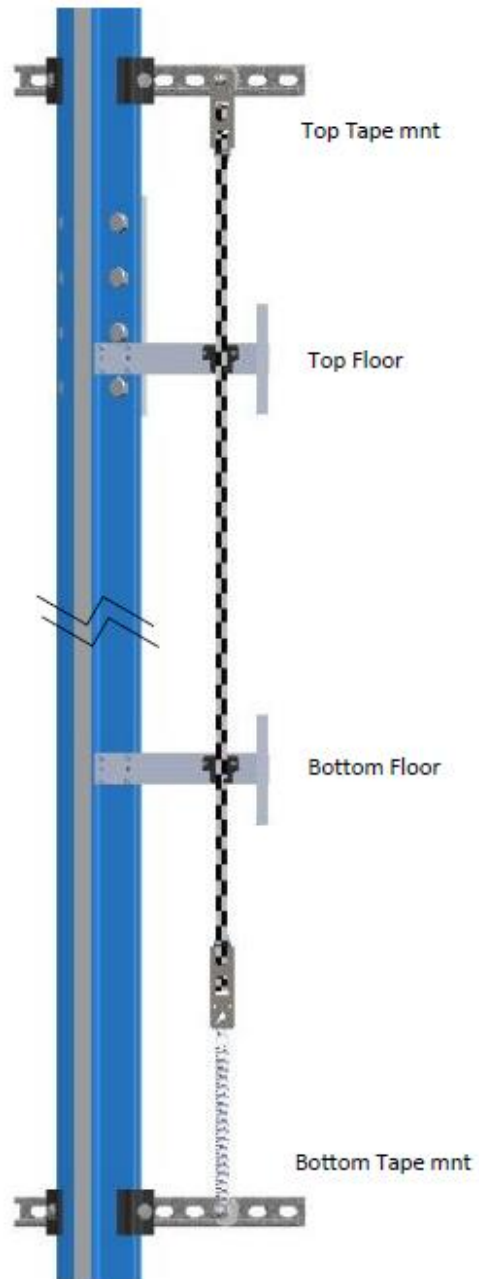


Figure 4: Complete Install

# 4.1 TAPE

Code Tape – this special coded tape provides the absolute positioning feedback to the *CEDES Camera*.



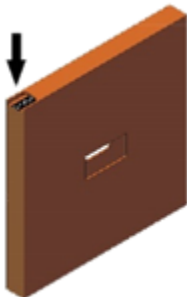
## Tape Installation



### **Caution:**

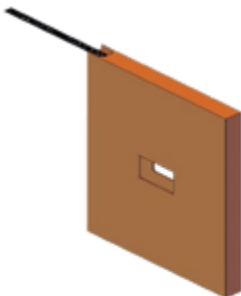
The tape edge is sharp! Whenever you see this symbol make sure you wear cut-proof gloves when handling the tape.

### **Step 1 – Tape - Open**



**Step 1:** Open the tape box at the top corner being careful of the sharp end or edge of the tape.

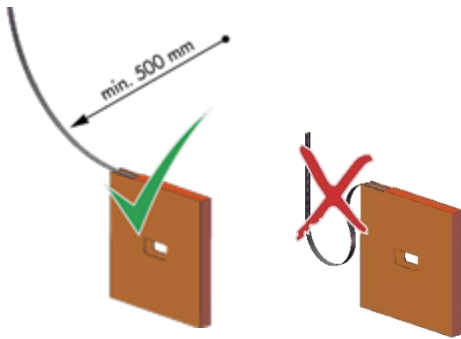
### **Step 2 – Tape – Dispense**



**Step 2:** Pull the tape straight out so that it can be attached to the Top Tape Bracket.



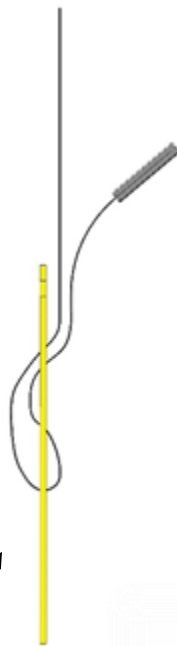
**Step 3 – Tape – Bend Radius**



**Step 3:** Pull a small amount of tape from the box as needed to complete Steps 4 & 5.

Caution: Don't pull too much out of the box as excessive bending in the tape can damage it.

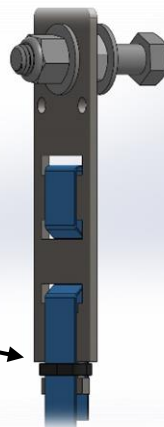
**Step 4 – Tape – Secure to Top Bracket**



**NOTE:** Make sure that the words "Left" are on the left side of the tape with the barcode facing out towards the camera.



**Step 4a:** Serpentine the tape through the bracket as shown. Zip tie afterward.



## 4.2 SENSOR ASSEMBLY

### Complete Sensor Assembly

Assembly contains; CEDES Optical Sensor, Optical Sensor mount bracket, CEDES Exact Position GLS Reader, Sensor Array bracket, and associated hardware. Note, sensors can be oriented differently as long as corresponding tape and blades are aligned correctly. Connect Optical Sensor and GLS Reader to the car top SRU board. Secure cabling.

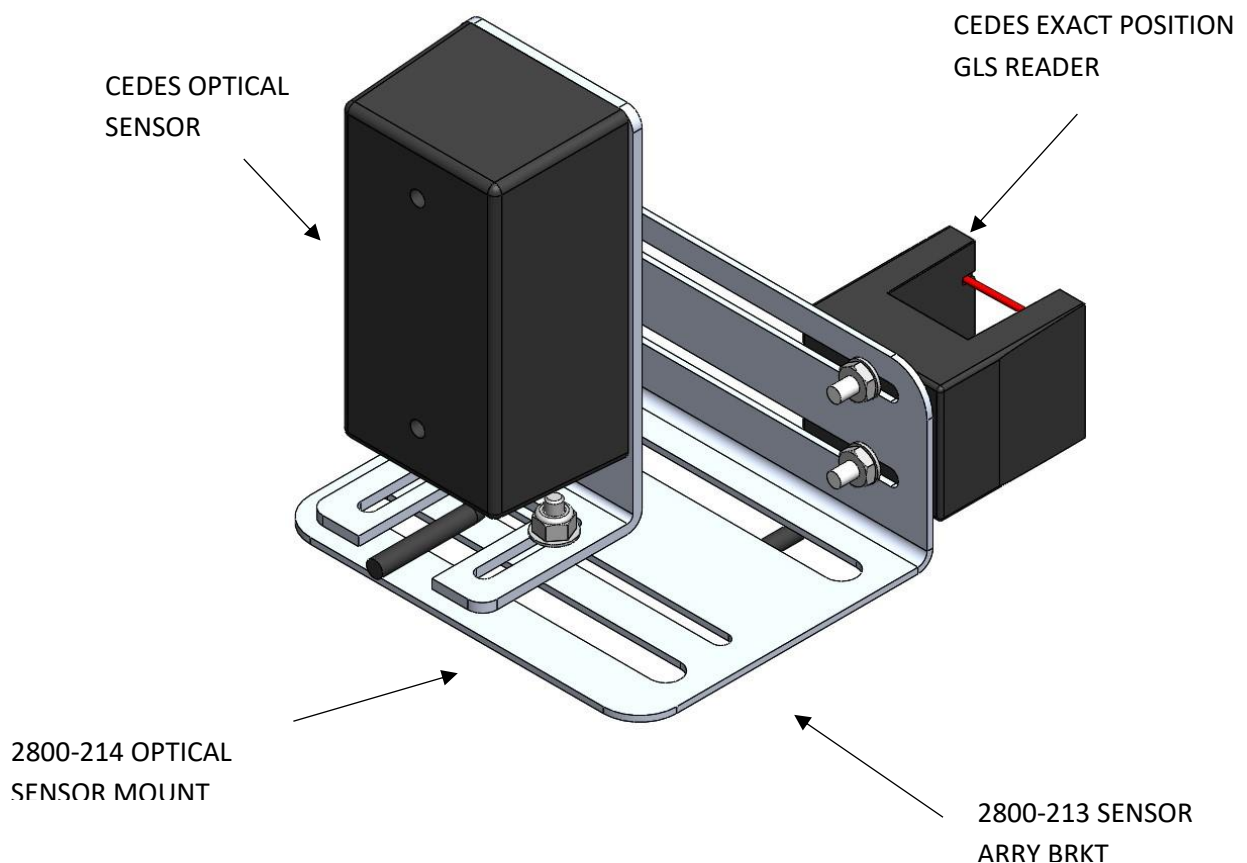


Figure 1: Sensor Assembly

### Secure Sensor Shelf Assembly to car top frame C-Channel

- Note: Exact positioning and lengths of Unistrut can be adjusted as needed as long as the Sensor Array is positioned as shown in figure 7.
- Cut two lengths of Unistrut to 18", and one length to 24".
- Bolt the two, 18" lengths of Unistrut to the C-channels as shown in figure 6.
- Bolt the 24" length of Unistrut to the two 18" lengths as shown in figure 6. Note: the 24" length may be bolted to the top of the two 18" lengths if desired.
- Temporarily affix a Tape Clip Assembly onto the guide rail to use as alignment for the Sensor Array Assembly. See figure 7.
- Set the end of the 24" Unistrut at 3.0" from the rear surface of the guide rail as shown in figure 7.
- Loosely bolt the Sensor Array Assembly onto the 24" Unistrut with the Door Zone Blade centered horizontally in the GLS Reader as shown in figure 7.
- Position the Sensor Array at the distances shown in figure 7 then tighten all bolts. Note: the Optical Sensor Mount bolts may be loosened if needed to adjust the position of the sensor.

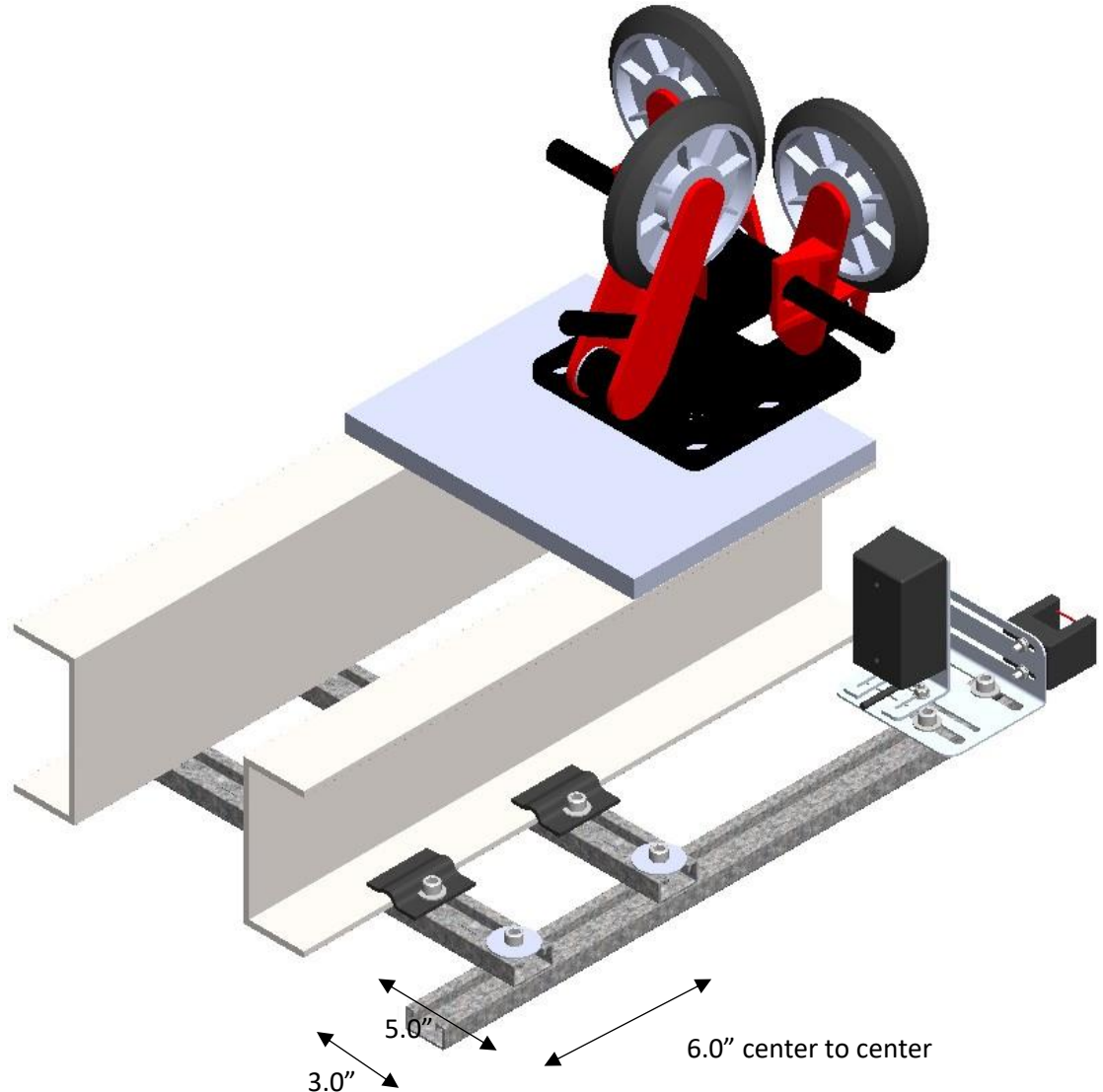


Figure 2: Unistrut installation

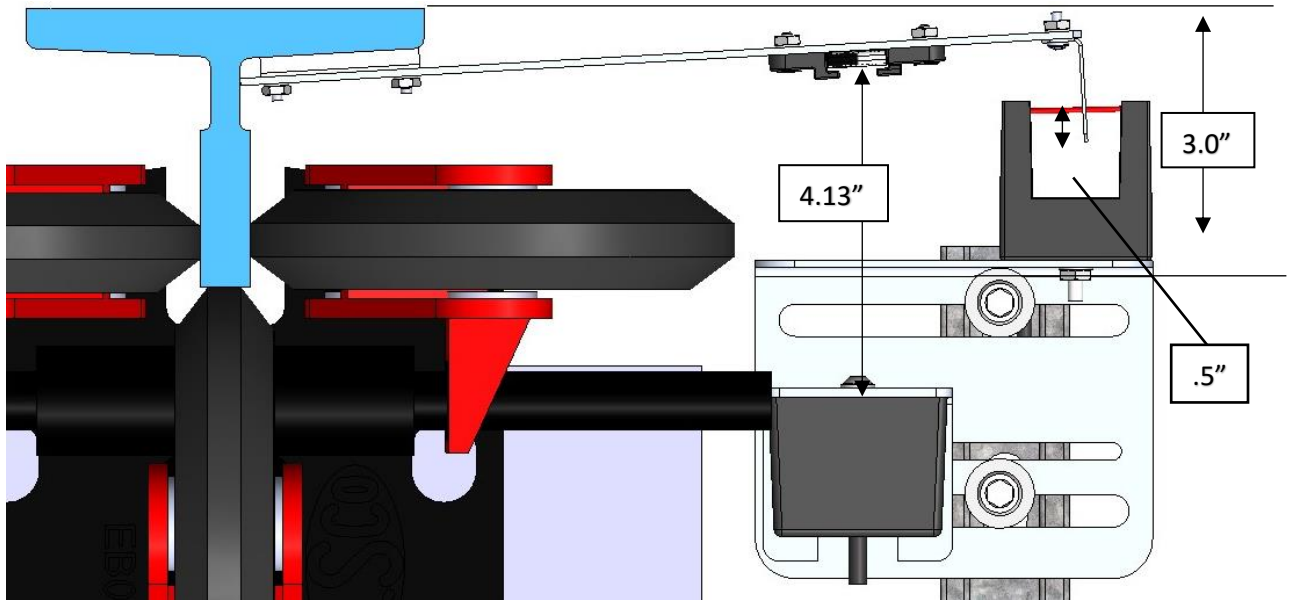


Figure 3: Sensor Array Assembly positioning

### Alternative Sensor Shelf Assembly Installation

- Space permitting, the Sensor Array Shelf may be installed on top of the C-channel beams as shown in figure 8.

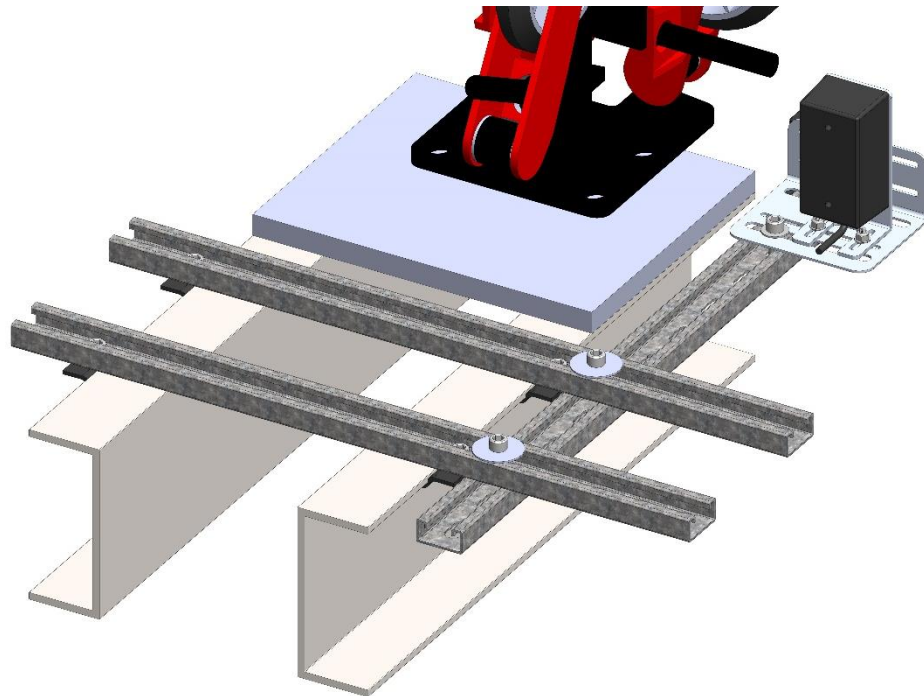


Figure 4: Alternate Unistrut installation

## 4.3 UPPER TAPE MOUNTING ASSEMBLY

### Top Tape Installation

- Affix an 18" length of Unistrut to the top of guide rail as shown in figure 9.
- Loosely assemble the Upper Tape Mounting Assembly in the order shown in figure 10.
- Position the Upper Tape Mount Assembly 9.36" from the surface of the guide rail to the center of the 3/8" bolt as shown in figure 9.
- Tighten the first hex nut to secure the assembly in place
- Thread the Nylock nut onto the bolt until there is a .2" gap between the two flat washers that are on either side of the Tape Interlock bracket as shown in figure 11. This gap is required to relieve twist in the tape.

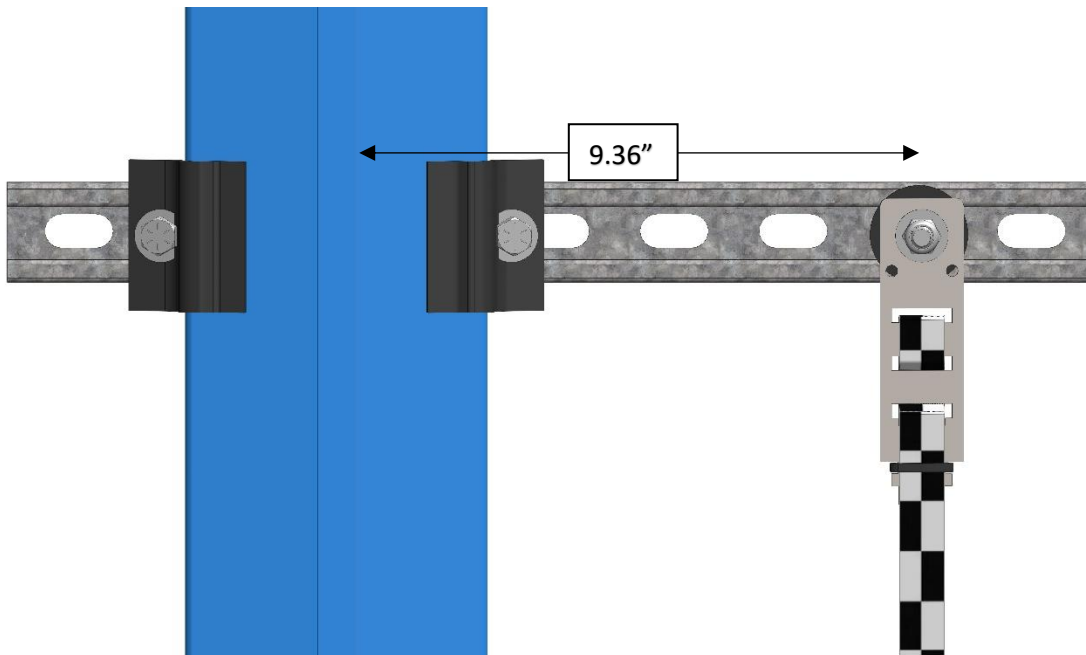


Figure 5: Upper tape Unistrut Installation

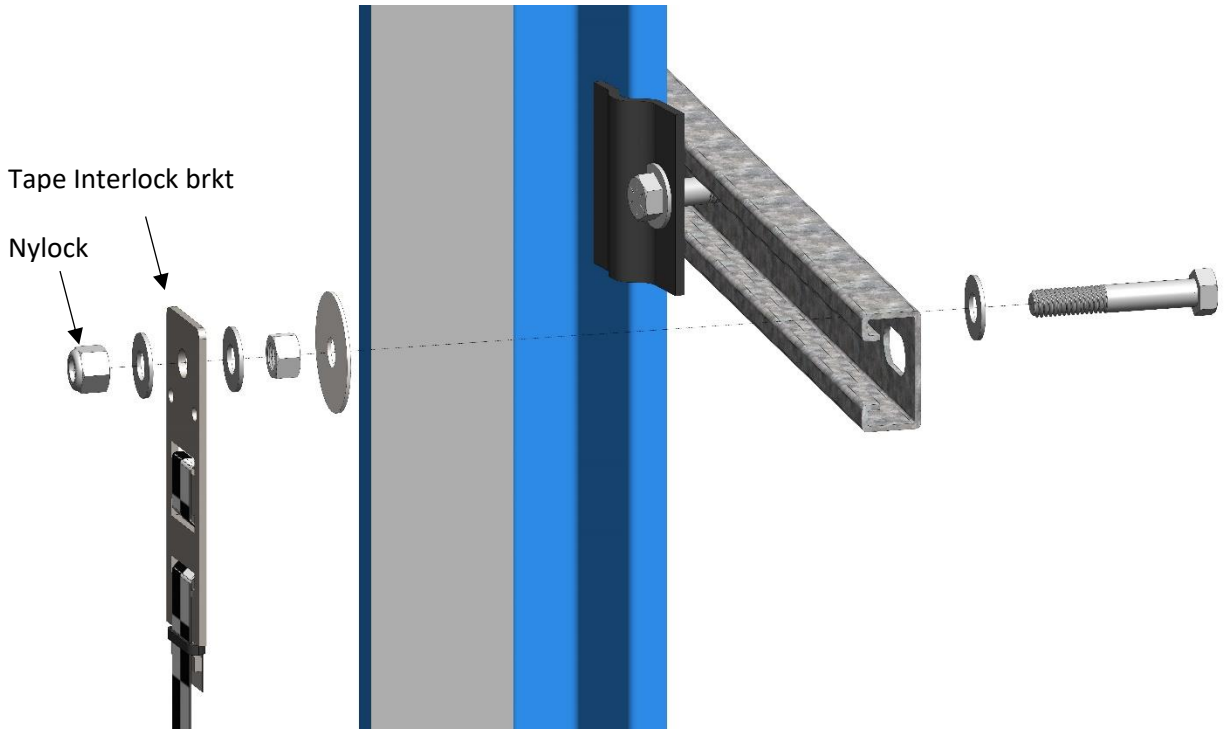


Figure 6: Upper tape mounting assembly

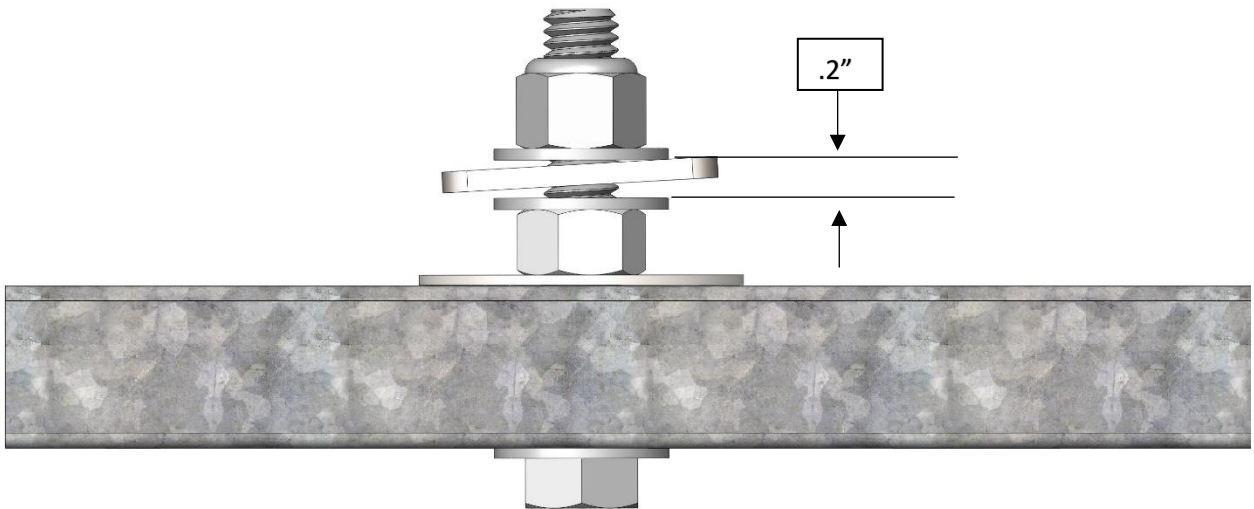


Figure 7: Upper tape mounting assembly

## 4.4 TAPE CLIP ASSEMBLY

### Tape Clip Assembly Installation

- As you descend, you will unspool the tape, install the Tape Clip assemblies and set the Door Zones.

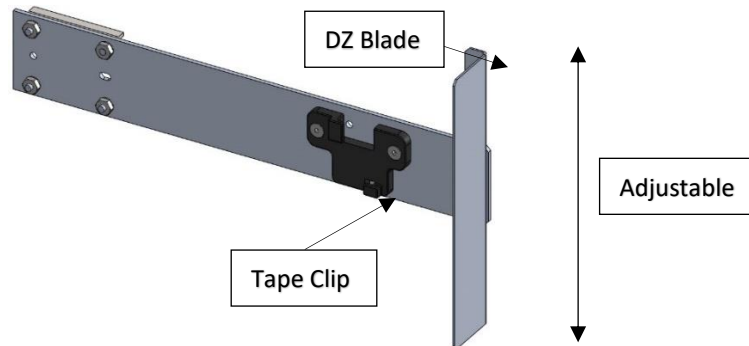
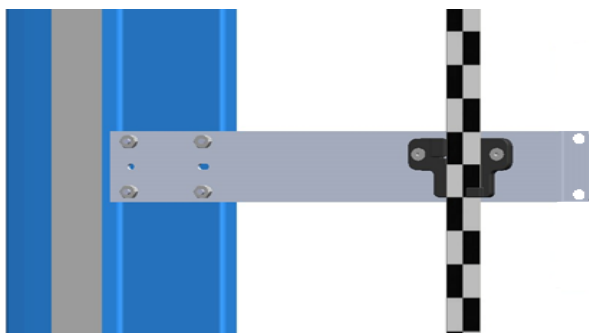


Figure 8: Tape Clip assembly

- The Tape Clip assembly includes the Tape Guide Clip, Door Zone Blade and the mounting magnets already preassembled.
- Bring the car to floor level.
- Wipe rail clean where clip assembly will be placed.
- Holding the Tape Clip assembly with one hand and the Tape with the other, rotate the Tape into the Tape Clip as shown in figure.
- Place the Tape Clip assembly onto the Guide Rail so that the DZ blade is centered vertically with the GLS reader Optical Axis as shown in figure 16.
- If there are bolts or other obstructions not allowing the assembly to be placed precisely where needed, then remove the two screws, washers and nuts securing the DZ Blade and adjust the blade up or down as needed.
- Ensure that the assembly is sitting flush to the rail as show in Figure 15.

**NOTE: In applications where there is 15ft of distance between door zones, you will need to place an extra bracket between those door zones. The Bracket will only contain the Tape Clip and NOT the DZ Blade. This will minimize tape twisting caused by long distances between Door Zones. These extra Tape Clip Brackets will be provided as needed.**



To install the guide clips:

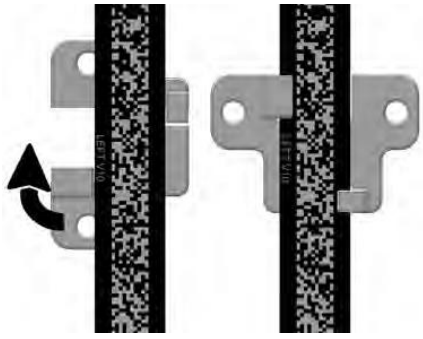


Figure 9: Tape Clip Insert Example

Insert Tape into guide clips by rotating it clockwise onto the tape.



Figure 14: Optical Axis

Optical Axis.



**CAUTION:** Be careful not to twist or bend the tape as it is lowered.

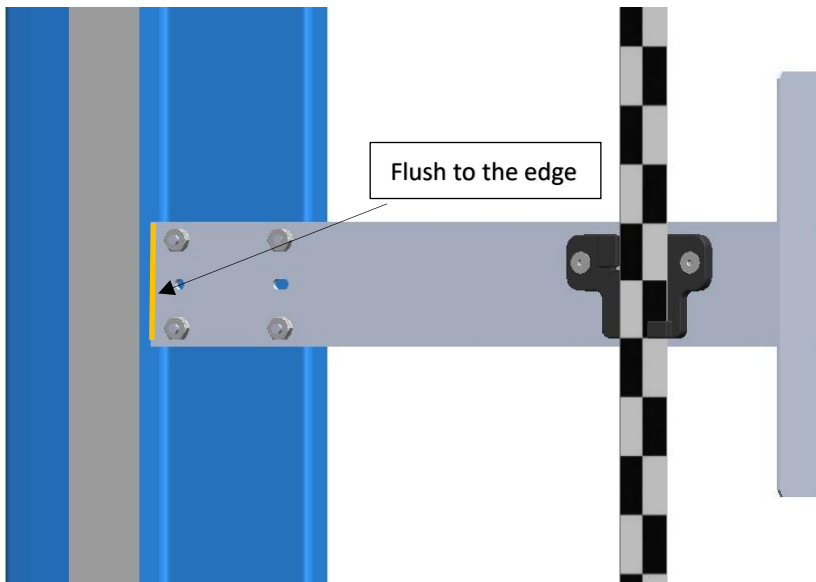


Figure 10: Tape Clip assembly Alignment



**CAUTION:** Do not remove bracket from rail by pulling from far end. This may bend the bracket.



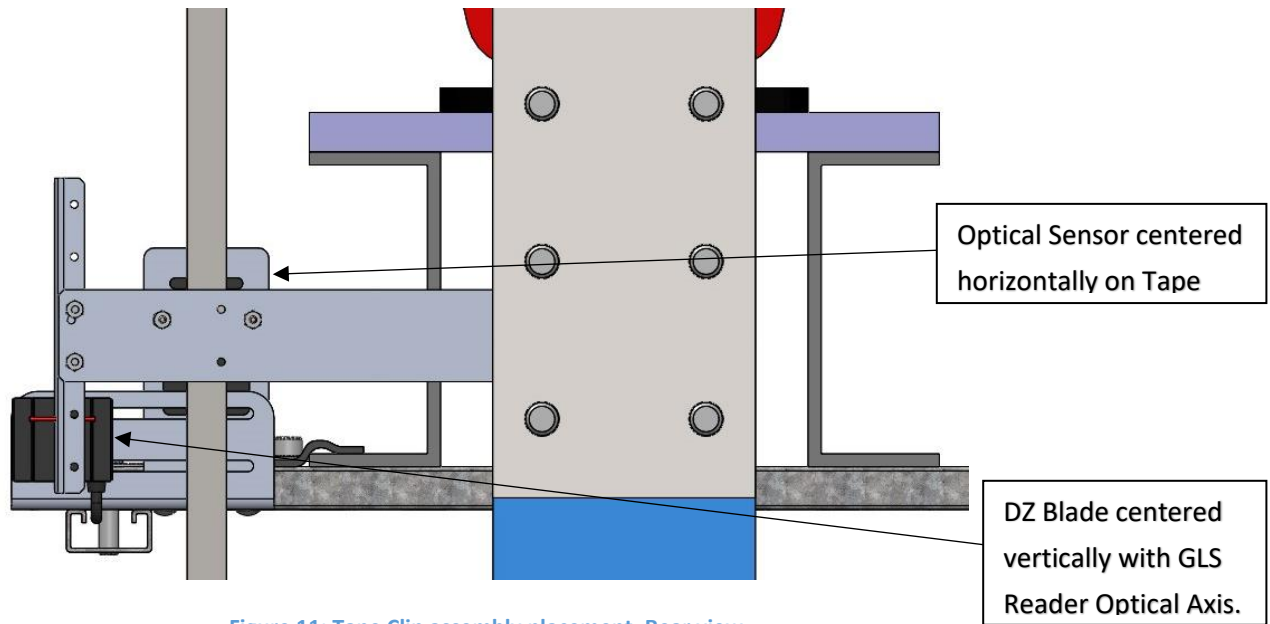


Figure 11: Tape Clip assembly placement. Rear view.

- An extension arm is provided if the assembly cannot be placed where desired.
- To install the extension arm, remove the DZ Blade from the Tape Clip assembly and install Door Zone Extension Arm using the same screws, nuts and washers, as shown in figure 17.
- Using two more Screws, nuts and washers provided in the install kit, mount the DZ Blade to the DZ Extension Arm in the desired location.

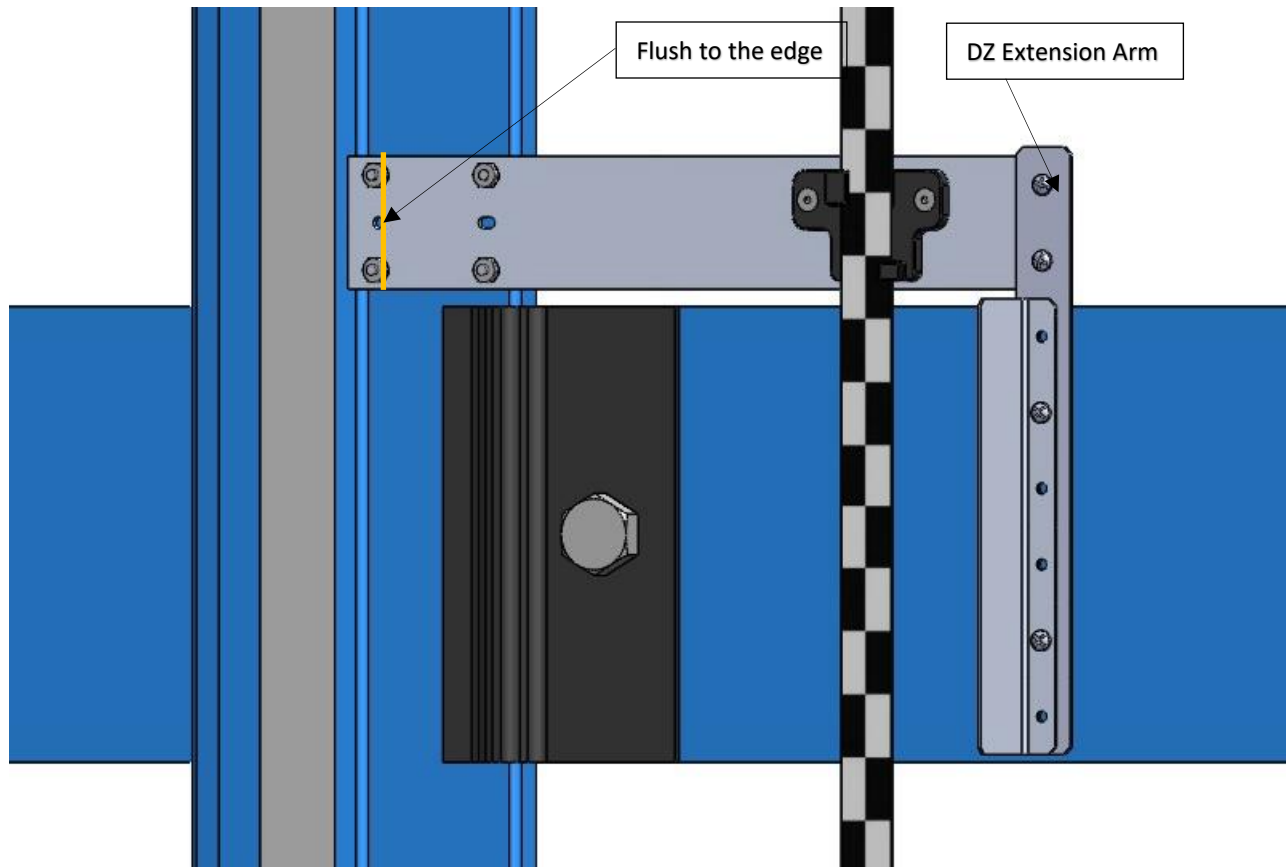


Figure 12: DZ Extension Arm

- Continue down the hoist way, placing the Tape Clip assembly at each landing.

## 4.5 LOWER TAPE MOUNTING ASSEMBLY

### Lower Tape Installation

- Affix an 18" length of Unistrut to the bottom of guide rail as shown in figure 19.
- Loosely assemble the Lower Tape Mounting Assembly in the order shown in figure 18.
- Position the Lower Tape Mount Assembly 9.36" from the surface of the guide rail to the center of the 3/8" bolt as shown in figure 19.
- Tighten the first hex nut to secure the assembly in place
- Thread the Nylock nut onto the bolt until the two flat washers that are on either side of the Spring are just touching the spring loop as shown in figure 18. This nut does not need to be tightened.
- Connect the spring to the Tape Interlock bracket using the Split Ring as shown below in figure 19.

- Ensure that the spring is stretched approximately 3 inches when installed.

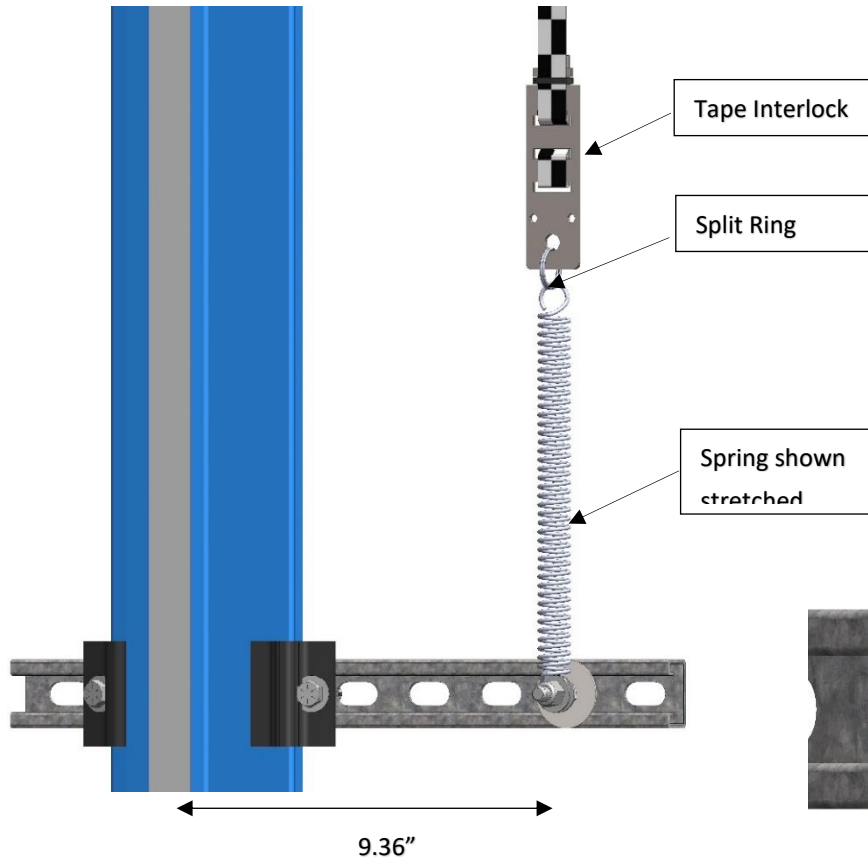


Figure 14: Bottom Tape Installation

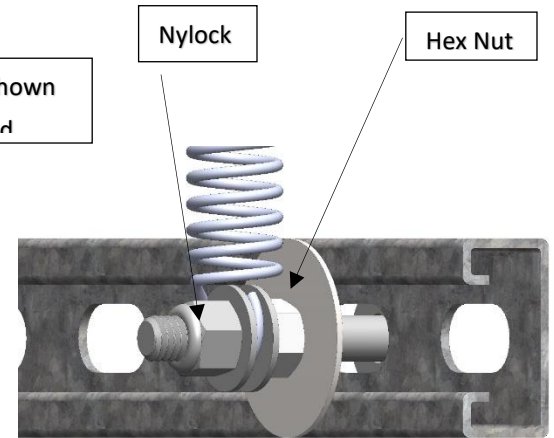


Figure 13: Bottom Tape Installation

## 4.6 EMERGENCY TAPE BREAK SWITCH ASSEMBLY

### [Emergency Tape Break Switch \(Optional\)](#)

- Affix a 12" length of Unistrut to the guide rail approximately 20" above the lower tape mounting assembly Unistrut as shown in figure 21.
- Attach bracket and switch to Unistrut as shown in figure 20.

Adjust the tension of the spring by raising or lowering the Unistrut Mounting Point so that there is 3" of stretch.

- Link the ETB switch to the tape interlock via the cable kit provided as shown in figure 21. Leave 1-2 inches of slack in the cable. Note: switch can be mounted vertically as well by inserting switch pull tab into bottom end; pull should always face downward as shown.

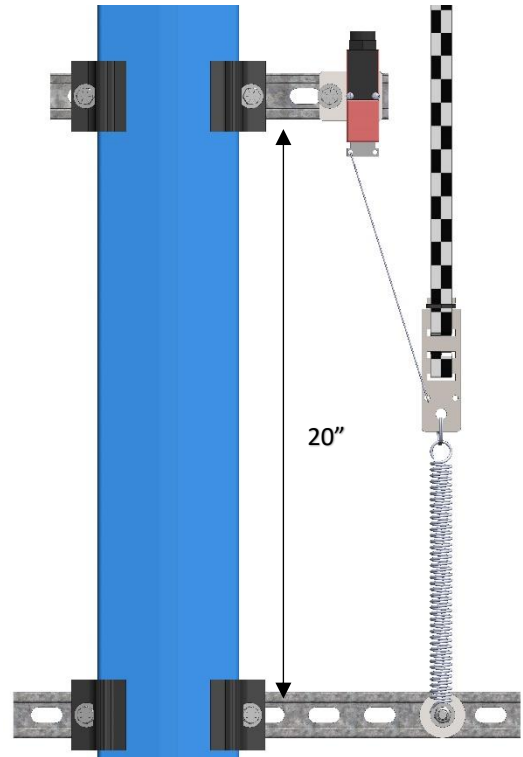
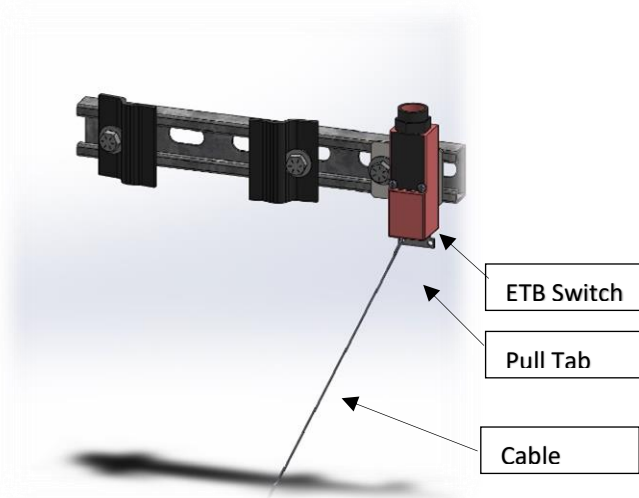
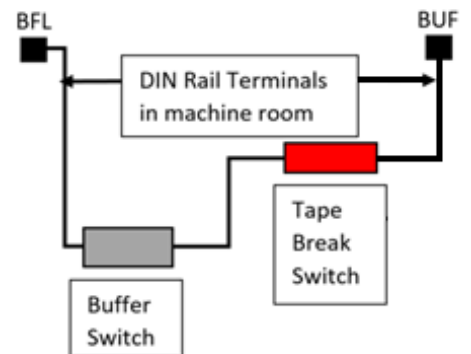


Figure 21: ETB Switch Setup

**NOTE:** The Emergency Tape Break Switch should be installed in the safety string in **series** with the Buffer Switch.

There should be slack in the wire when the tape tension spring is fully extended. This slack will allow for tape and/or building movement.

If the tape breaks, the Tension Spring will retract and pull the cable attachment out of the Emergency Tape Break Switch, opening the safety string. Make sure that the cable length allows the tab to pull out of the Tape Break Switch when the spring is retracted.



## 4.7 FINE TUNE

See Camera Alignment section for camera placement. Camera should be at a distance of 4.13" from tape. \*Tolerance of camera is +, - 1 cm\*.

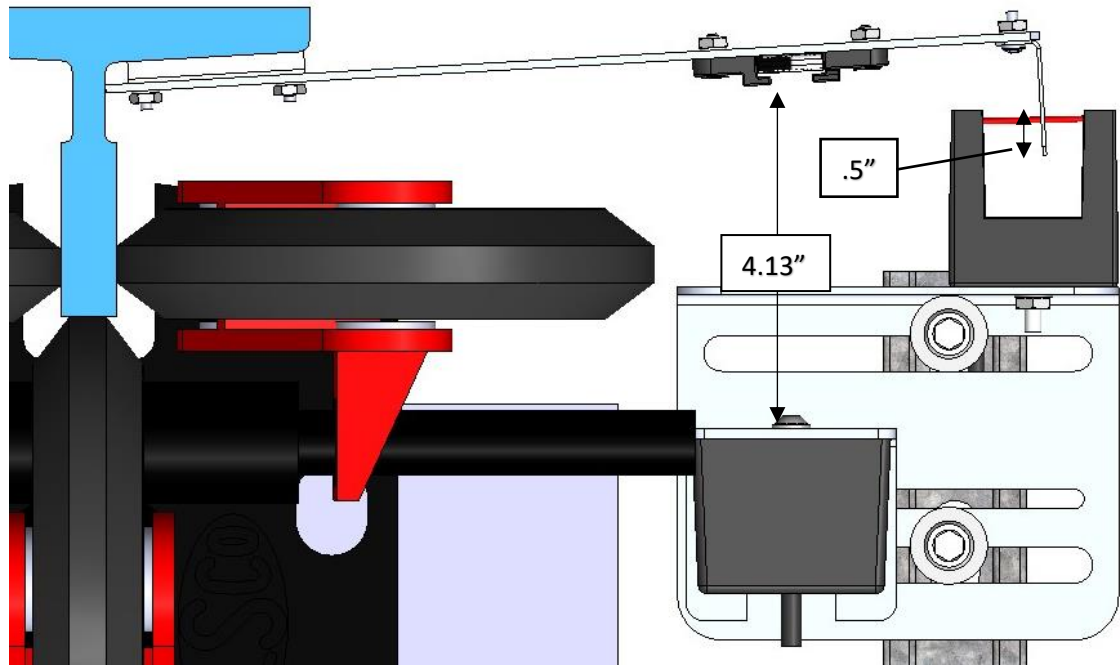


Figure 15: Camera Tuning

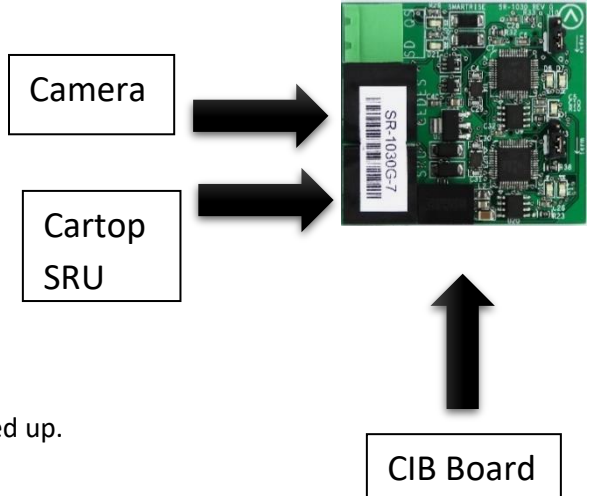
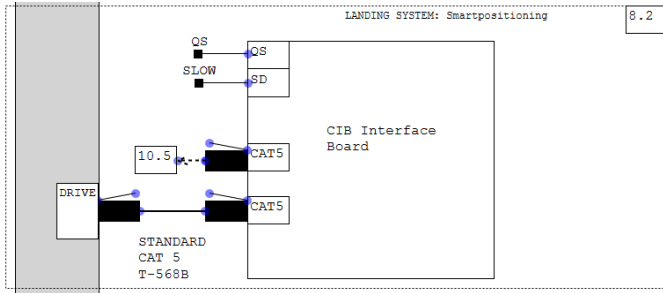
Power the APS camera via RJ45 to the car top's SRU board so a red array can be seen on the tape to allow for alignment. If no red array is seen on tape, reset power by unplugging and reinserting to RJ45 Jack.

### Verify

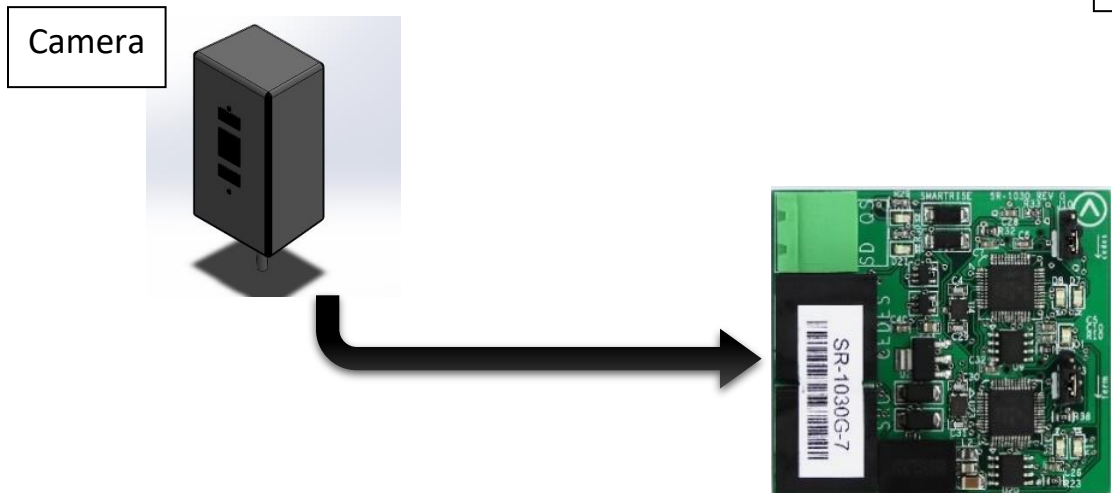
Proceed on inspection up/down the hoist way and adjust each tape guide clip to the correct in-line position with respect to the sensor assembly.

# 4.8 CAMERA CONNECTIONS

Connect the cable from the camera (with a CAT5 connector) to the CAT5 port on the CIB interface board, labeled as “CEDES” located in the cartop box.



The camera will power up when the cartop station is powered up.

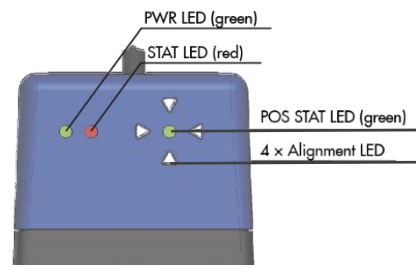


## 4.9 CAMERA ALIGNMENT

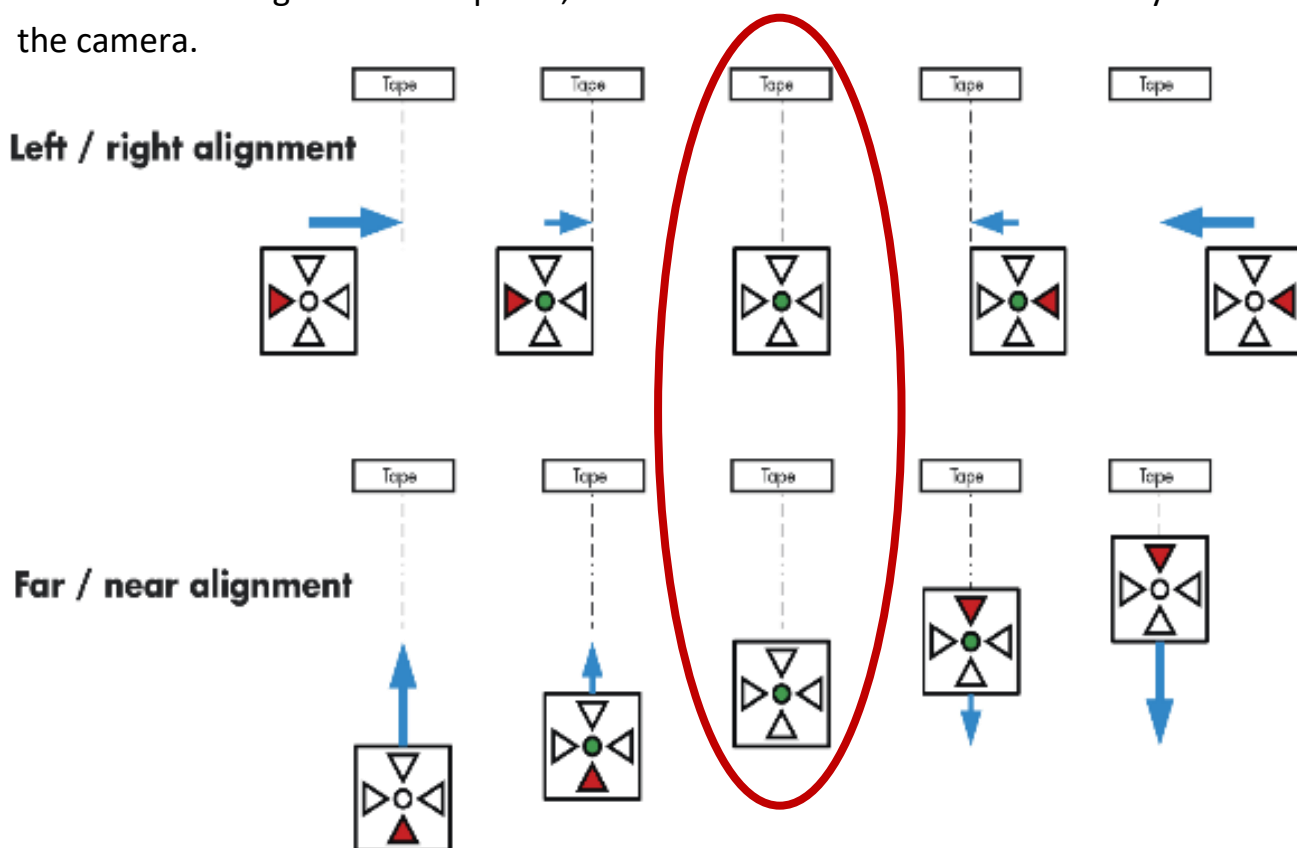
Use the Alignment and Position Status LEDs on the top of the Camera to align the camera to the tape.

Loosen the two mounting bolts on the camera mounting plate to adjust the cameras position.

The following illustration shows how to position the camera for proper alignment using the alignment LEDs.



When camera alignment is required, the red arrow LEDs indicate which way to move the camera.



**Left / Right Alignment:** Using the directional arrows on the top of the camera, move the camera left or right until only the green POS STAT is on.

**Far / Near Alignment:** Using the directional arrows on the top of the camera, move the camera closer to or further away from the tape until only the green POS STAT is on.

Once the alignment is complete, tighten the camera mounting plate.

Run the car on inspection from terminal-to-terminal while watching the POS LED on the top of the camera to make sure that the camera is aligned with the tape for the entire length of travel.

As you travel up and down the hoistway, the red alignment arrow LED's may flash on and off. This is OK as long as the center green LED stays lit

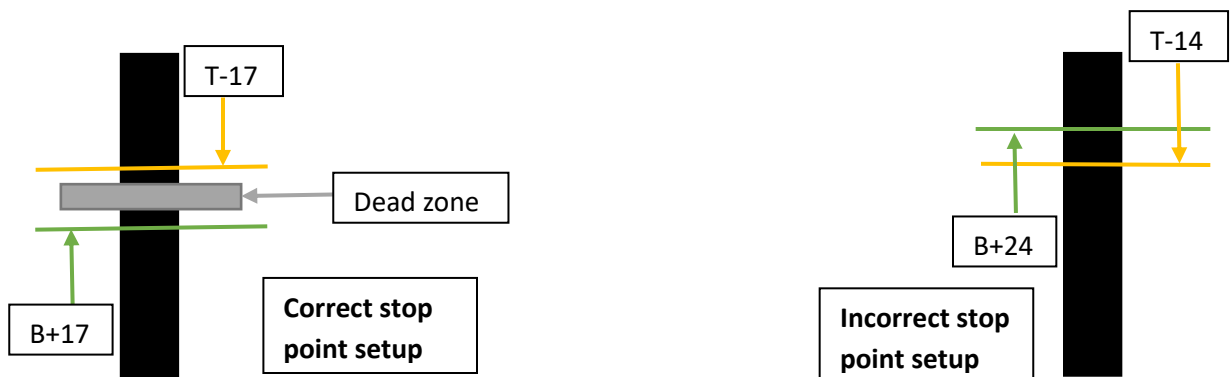
## 5.1 SOFTWARE

Your system comes with the latest updated software. These set up will only work if you have the software version 2.48 or higher. You can check what software version you have by going to MAIN MENU, ABOUT. If you do not have software version 2.48 or higher please refer to the Smartrise Equipment Installation Manual 2.74. Contact technical support at 916-457-5129 for software issues.

## 5.2 Learning the Hoistway

1. Bring the car to the bottom door zone on inspection.
2. On the MR SRU board, turn on DIP #2 on DIP A. The main screen should switch from Normal to Learn. Ensure MR inspection is in the normal state.
3. Navigate to Learn Mode commands menu located in **MAIN MENU | SETUP | LEARN MODE COMMANDS**
4. Begin the LEARN MAGNETS and the car will stop at the top floor door zone.

**Note: Please make sure the car learns the hoistway at a speed of 10 FPM.**



## 5.3 Setting up ETS (Emergency Terminal Slowdown – TRACTION ONLY)

**(Setting up ETS is only for Tractions, if it's a hydraulic elevator please skip this step and move on to Section 5.4)**

**After you finish learning the hoistway:**

Find out what the distance is for the bottom of your top door zone magnet is by going into MAIN MENU, STATUS, MAGNETS, and scroll up to the top floor. Find out what the distance is for the top of your bottom door zone magnet by going into MAIN MENU, STATUS, MAGNETS, and scroll down to the bottom floor.



To setup the ETS device, you need to adjust two parameters in the SRU menu. The parameters can be found under the Setup menu as:

SETUP | ETS SETUP | SET UETS POSITION  
 SETUP | ETS SETUP | SET DETS POSITION

Older Smartrise controllers used hoistway switches or magnets near the top and bottom terminals to perform ETS. These have been replaced by parameters which act as “virtual hoistway switches”.

Set the UETS POSITION parameter to a value indicating where a physical ETS switch would be placed at the top of the hoistway. When the car passes this position going up, the ETS device will open the SF1 relay if the car has failed to slowdown for the top terminal.

Set the DETS POSITION parameter to a value indicating where a physical ETS switch would be placed at the bottom of the hoistway. When the car passes this position going down, the ETS device will open the SF1 relay if the car has failed to slowdown for the bottom terminal.

<b>ETS Switch Positioning Table</b>		
<b>Contract Speed</b>	<b>UET Position</b>	<b>DET Position</b>
10-100	8"	8"
101-125	10"	10"
126-150	12"	12"
151-175	14"	14"
176-200	16"	16"
201-225	18"	18"
226-250	20"	20"
251-275	22"	22"
276-300	24"	24"
301-325	26"	26"
326-350	28"	28"
351-375	30"	30"
376-400	32"	32"
401-425	34"	34"
426-450	36"	36"
451-475	38"	38"
476-500	40"	40"
501-525	42"	42"
526-550	44"	44"
551-575	46"	46"
576-600	48"	48"

## 5.4 Setting UP TSRD (Terminal Slowdown Reducing Device – HYDRAULLIC ONLY)

After learning the hoistway:

1. Find out what the distance is for the bottom of your top door zone magnet is by going into main menu, status, magnets, and scroll up to the top floor.
2. Once that is done, you will place your TSRD using the chart below. You will be placing your TSRD from the distance below from the bottom of your top door zone magnet.

<b>Hoistway Switch Positioning Table</b>	
<b>Contract Speed</b>	<b>TSRD POSITION</b>
10 - 100	9"
101 - 125	10"
126 - 150	12"
151 - 175	14"
176 - 200	16"

# TAPELESS LANDING SYSTEM

## DESCRIPTIONS

Bistable Sensors (ETS/NTS) – The Gray Bistable Sensor on the Rail Encoder Landing system reads the ETS and NTS magnets on the extension plates. It is latching so it changes state whenever it crosses over the lifesaver magnets.



Mono-Stable Sensors (DZ) – The Black Monostable Sensor reads the Door Zone (DZ) magnets on the rails. Some installations require 2 door zones (DZ1 / DZ2) so two cigar sensors would be used. It is Non-latching so it only changes state while it is passing over the 6” magnets.

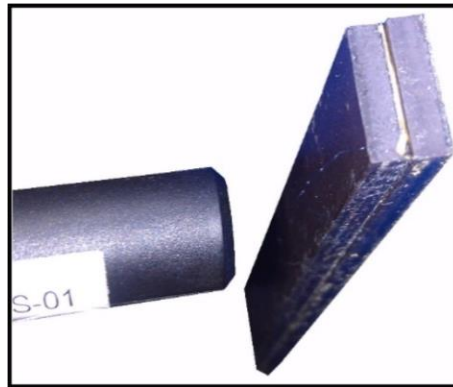
## DOOR ZONE MAGNETS

Refer to “*UET/DET MAGNET PLACEMENT – BEAM*” illustration

The Door Zone magnets are 6” black magnets placed on a steel beam so that the black “cigar” sensor, mounted on the cartop, can see them when it passes over.

The door zone magnets are double stacked and aligned along the inside of the beam.

For best operation, the black Monostable sensor should be adjusted ½” away from the *double-stacked* DZ magnets.



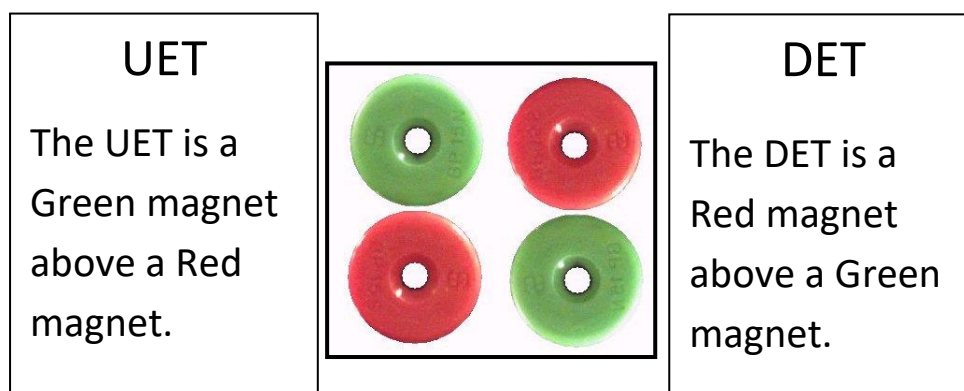
### ETS (LIFESAVER) MAGNETS

The ETS magnets for the Steel Beam landing system are 2” round reversible magnets and perform a similar function as their flat magnet counterparts. The RED side closes the bi-stable switch and the GREEN side opens the bi-stable switch.

The orientation of the magnets determine when the ETS switch closes (in middle of hoistway) and when it opens (at terminal landings). The upper Emergency Terminal Stopping magnets (UETS) and lower (DETS) provide an indication that the car is near the top terminal (UET) or bottom terminal (DET).

Improper orientation will cause the signals to not function properly and the car to fail the Learn Procedure.

Because the cigar sensor is Bistable (latching) it remains in the same state even when power is turned off.



## SENSOR HEAD

The sensor head straddles one of the cars guide rails and contains (x2) Door Zone sensors and (x2) ETS sensors.



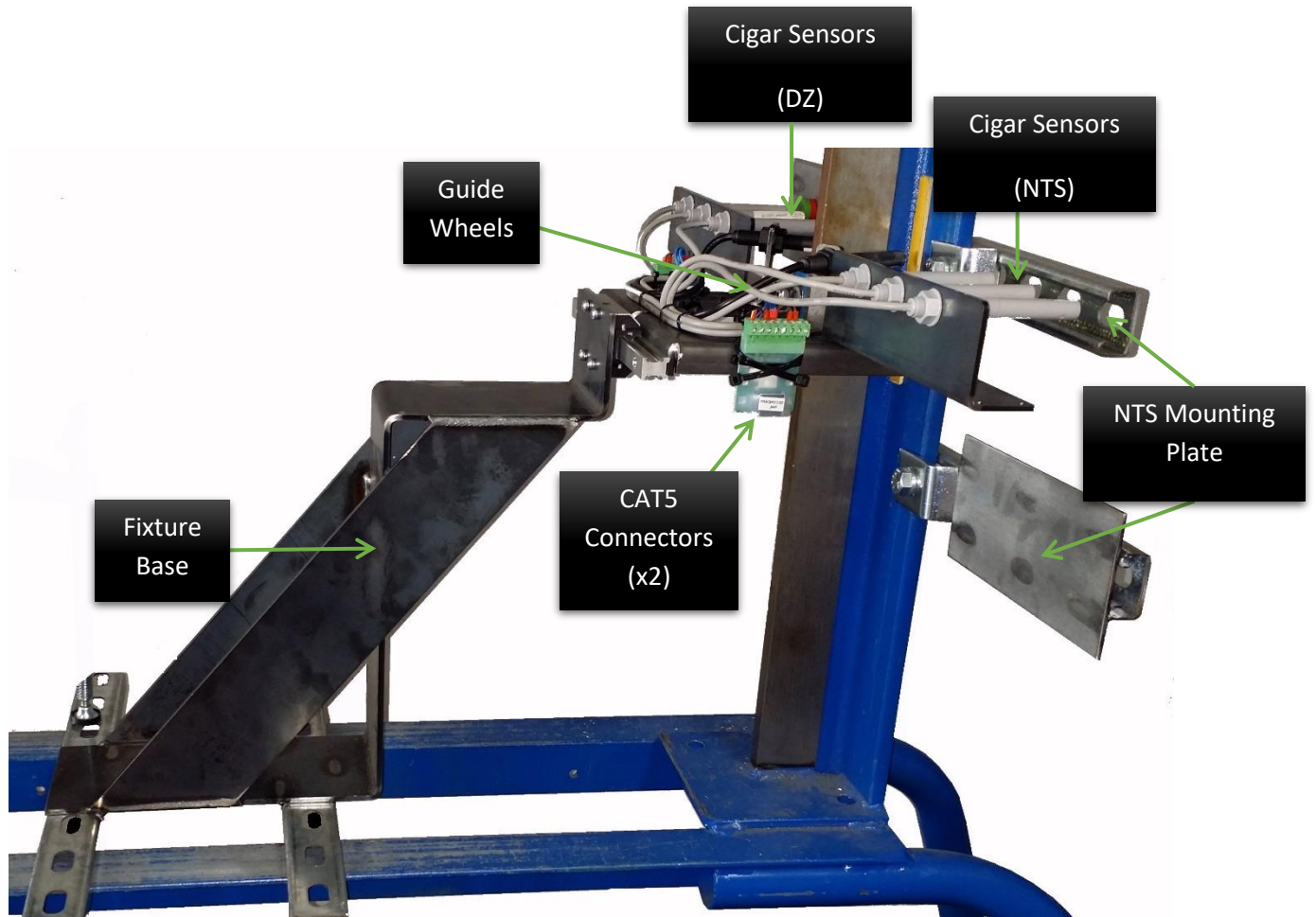
## GOVERNOR ENCODER

Smartrise recommends using the Governor Encoder landing system on jobs that are greater than 12 landings or faster than 350 FPM.

The governor encoder is installed on the governor shaft in the machine room and the feedback wires go to the cartop SRU board via a shielded pair in the traveler cable.

# GOVERNOR ENCODER LANDING SYSTEM INSTALLATION

## Introduction



## Tapeless Landing System Mount

Install the fixture on top of the car so that the Blue Guide wheels are on both sides of the center of the guide rail. There are 4 mounting brackets supplied for easy installation and removal.



The fixture should be mounted so that the outer edge of the guide wheels (flat side) run along the outer edge of the center guide rail.

When installed correctly, a flat edge can be placed across both guide wheels and the narrow face of the guide rail and should make contact with all three surfaces.

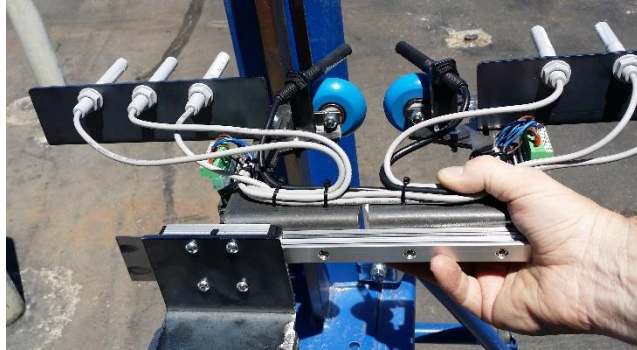




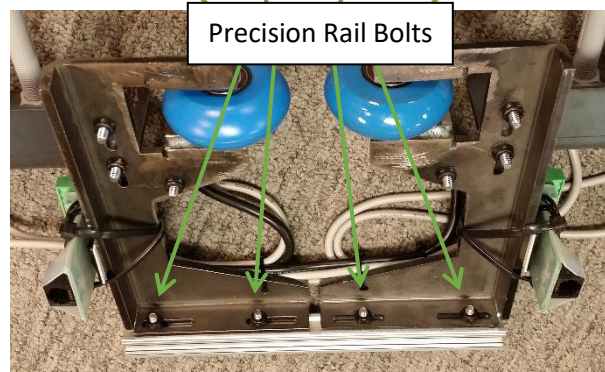
## Adjusting the Guide Wheels

The guide wheels are pre-adjusted for a standard 15lb. rail width from the factory. The following procedure should be used to ensure proper placement on the guide rail.

If the guide wheels are not adjusted to the appropriate guide rail width, loosen (don't remove) the precision rail mounting bolts (x4) on the sensor assembly.



The bolts allow you to adjust the wheel mounts to fit the guide rail. Slide the sensor assembly back onto the base and slide the whole assembly onto the rail.



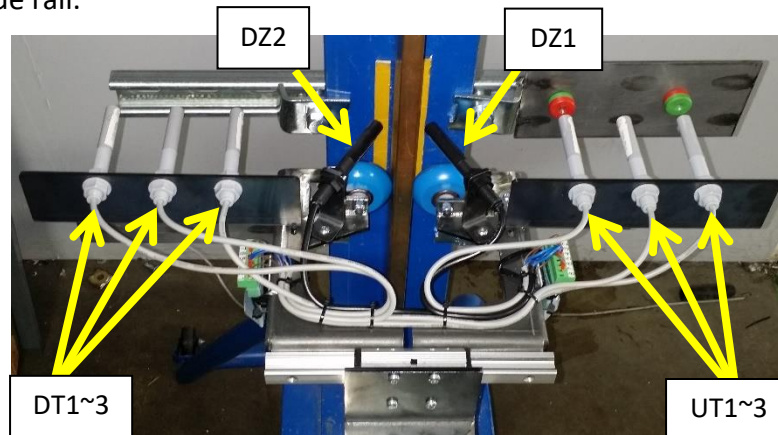
Set the wheel rail width so that the wheels are not too tight against the rail. Tighten the 2 outside precision rail bolts. Now move the assembly away from the guide rail and tighten the inside bolts. Now move the rail back onto the guide rail and secure the assembly mount to the crosshead.



## Adjusting the “Cigar” Magnet Sensors

There are two black “Cigar Sensors” installed on each side of the guide rail. Each Monostable and Bistable sensor is for sensing the Door Zone (DZ) magnets.

The Monostable Sensors (Black) are for reading the Door Zone (DZ1) magnets. These read the 6” North Pole magnets that are doubled up and installed closest to the center web of the guide rail. Version 3 software requires both the DZ1 & DZ2 magnets installed on both sides of the center web of the guide rail.

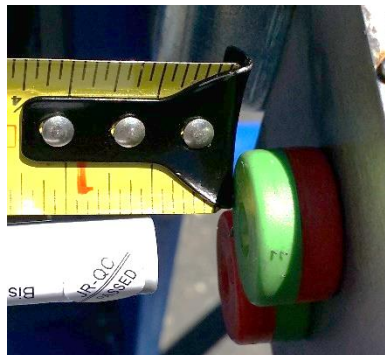


The Bistable Sensors (Grey) are for reading the round NTS “Lifesaver” magnets. These sensors read the magnets mounted on a separate plate that’s bolted to the guide rail. The right side is for the Up NTS (UT# - Up Terminal Slowdown) magnets and the other side reads the Down NTS (DT# - Down Terminal Slowdown) magnets.

The DZ1 & DZ2 magnets are installed next to the central protruding part of the guide rail and are doubled up during installation.

The lifesaver magnets are not doubled up when installed and they’re placed on the NTS mounting plates attached to the guide rail.

All of the sensors should be installed with no more than ½” distance from the end of the sensor head to the face of the magnets.



The last thing to check is that the sensors clear the hardware that anchors the guide rail to the building. Slowly move the car in CT Inspection and verify that the sensors all clear the guide rail anchoring hardware during entire length of travel.

## Installing the NTS mounting plates on the Guide Rail

There is one mounting plate for each NTS magnet set. These plates are installed on the backside of the guide rail using the supplied clamps.



The clamps should be slid all the way against the outside edge of the rail for the best support.



The magnet surface plate should be facing outward towards the car, providing a smooth surface for magnet placement. Make sure the plate can accommodate the magnet placement in regards to the sensor placements.

## V3 Terminal Label Descriptions

### Top Terminal

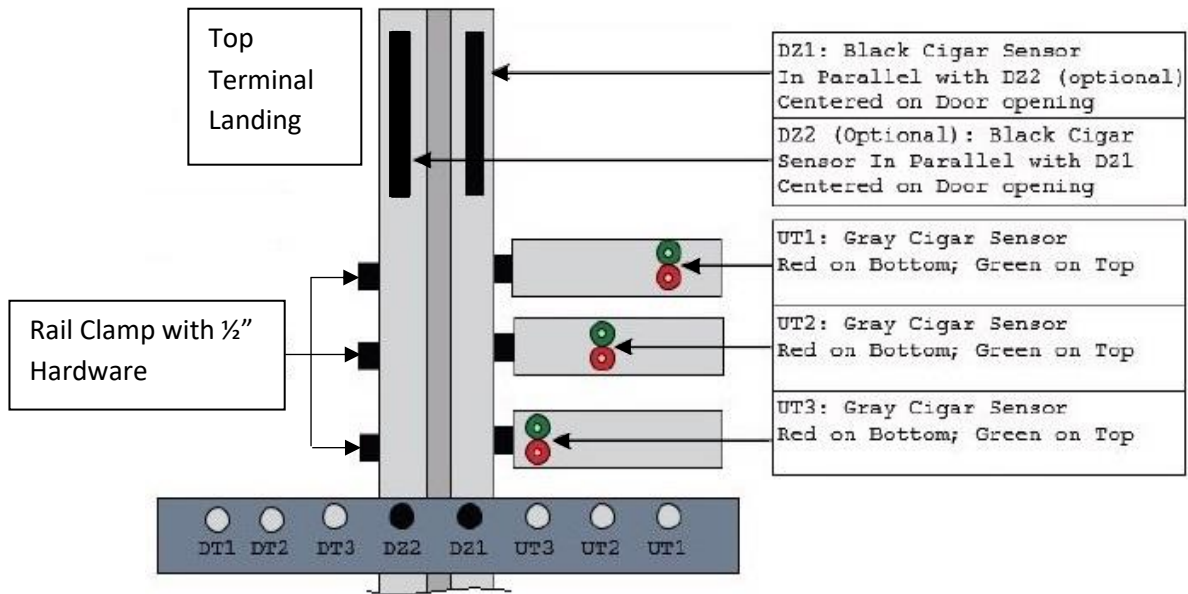
DIN Rail	UET	UT1	UT2	UT3
Description	UETS	UNTS1	UNTS2	UNTS3

### Bottom Terminal

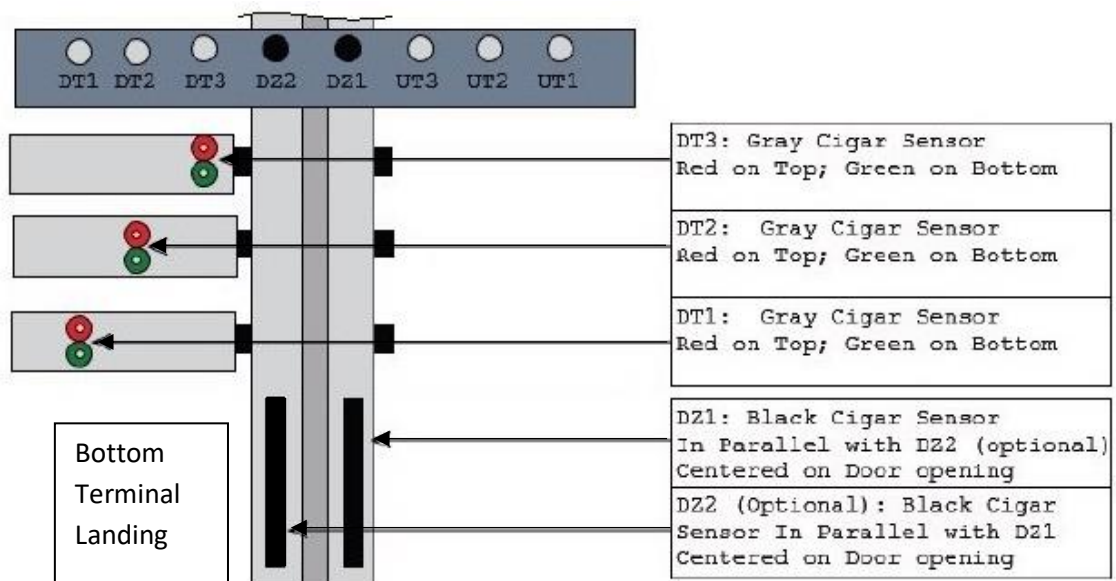
DIN Rail	DET	DT1	DT2	DT3
Description	DETS	DNTS1	DNTS2	UNTS3

## Installing the Magnets

The installation of the top terminal NTS magnets is shown in the following diagram:



The installation of the bottom terminal NTS magnets is shown in the following diagram:



## Positioning the NTS Magnets

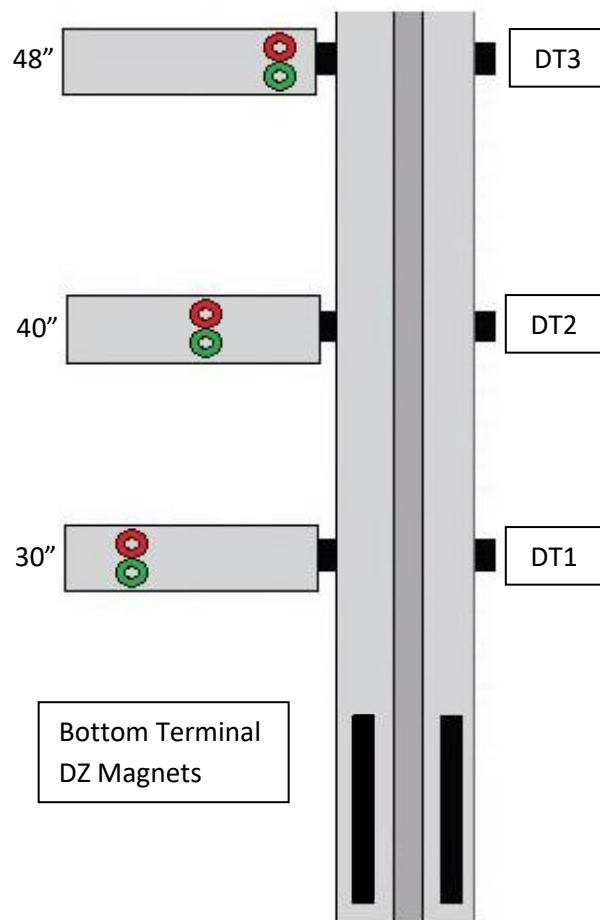
A good starting point for placing the NTS magnet brackets on the rail is by using the Hoistway Switch Positioning Table from the “Sheet 01: Getting Started” page of the Smartrise drawings.

This table provides a starting distance for the NTS magnets for V3 software controllers and should be used for reference only.

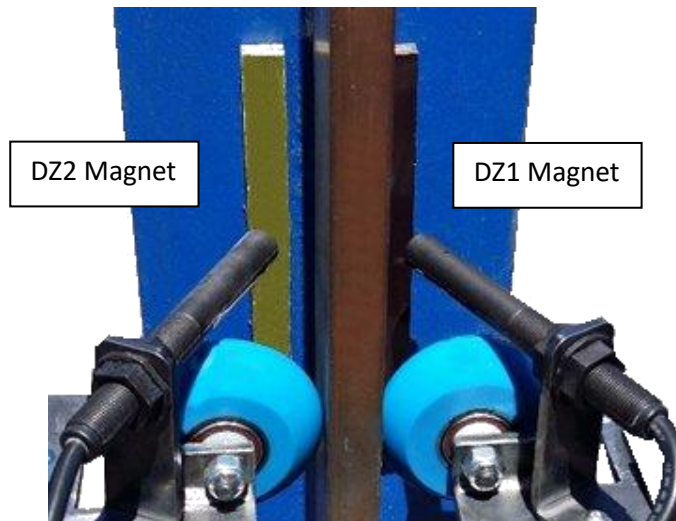
The actual distance will be determined by using the “NTS Switch Drive Setup” and the “NTS Switch Position Setup” procedure in the Smartrise Equipment Installation Manual.

The following example shows the initial installation distance using the Hoistway Switch Positioning Table for a 350FPM car.

Hoistway Switch Positioning Table			
Up To Speed	UT1/ DT1	UT2/ DT2	UT3/ DT3
50	6	6	X
100	6	11	X
150	9	16	X
200	11	21	X
250	13	28	X
300	22	31	X
350	30	40	48
400	38	48	60
450	49	60	70

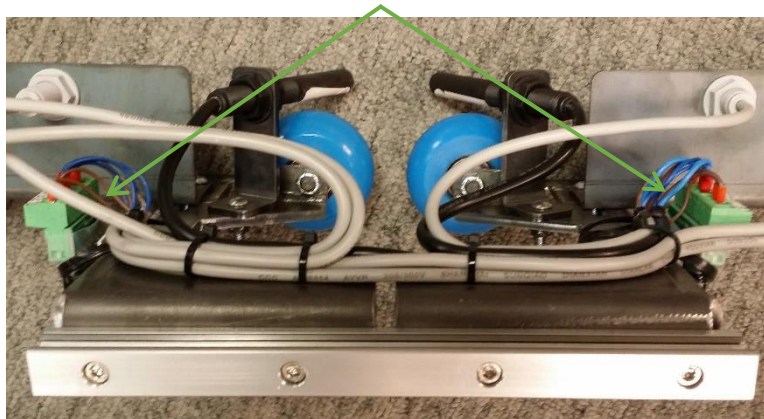


The following picture shows the sensor rail placement in regards to the DZ the magnets:



### Final Setup for the Tapeless Landing System

1. Install the CAT5 cables from the “Landing System” breakout boards to the Car-Top enclosure.

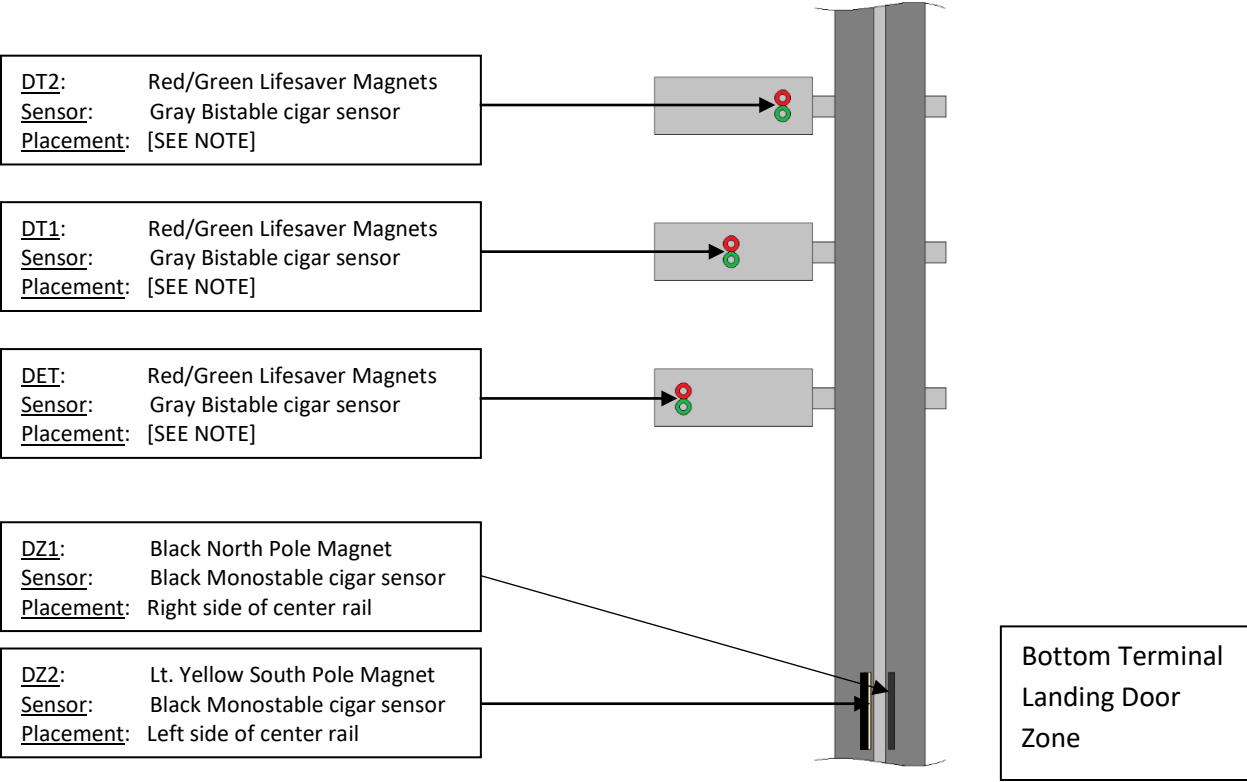
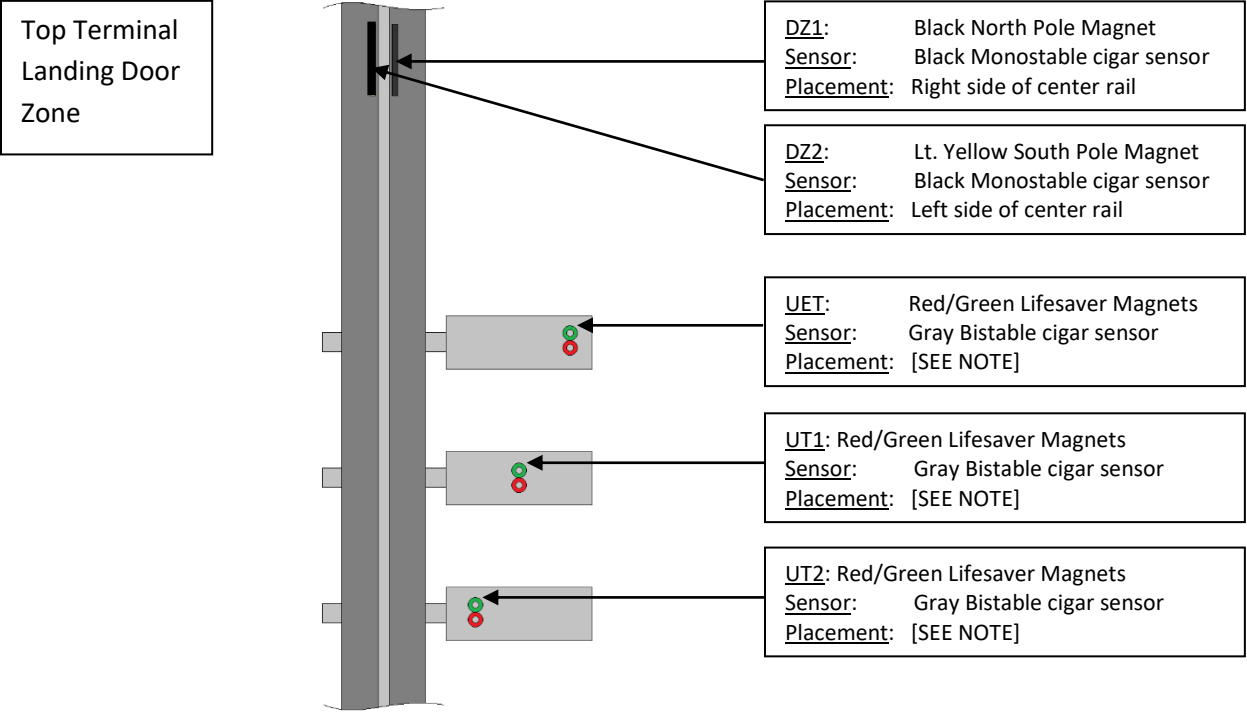


2. Make sure the (DZ) magnets are installed properly at the floor levels. Refer to the “Magnet Placement” section of the Smartrise manual for additional placement instructions if required.
3. Verify that the proper signals are flagging on the CT SRU board from the landing system

### CIGAR SENSORS

The Door Zone (DZ) and ETS magnets are read by long sensors typically known as “Cigar Sensors”.

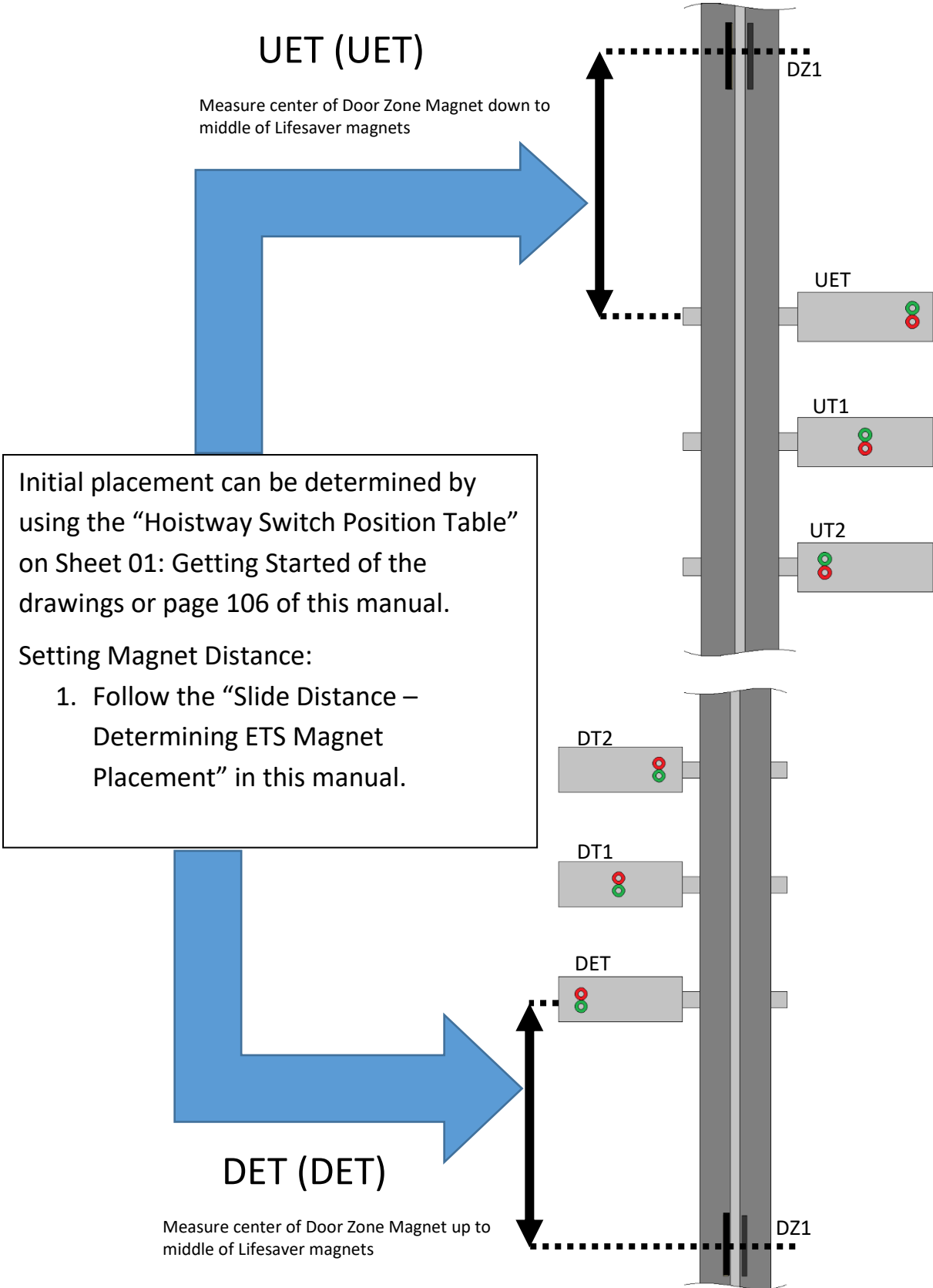
# UT#/DT# MAGNET ALIGNMENT – RAIL



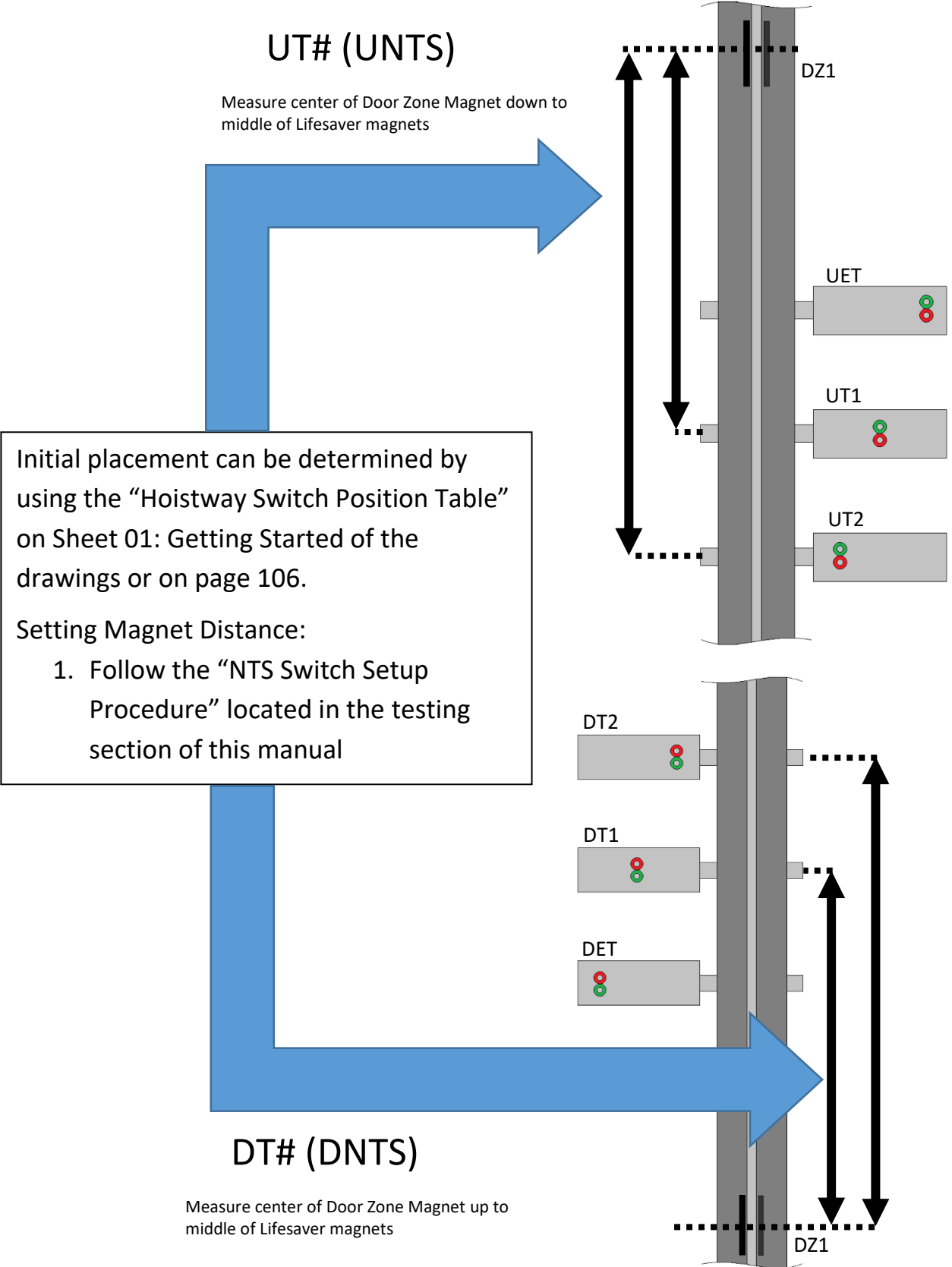
NOTE: The actual distance will be determined by using the actual slide distance determined from the “Slide Distance – Determining ETS Magnet Placement” procedure on the following pages.



# UET/DET MAGNET PLACEMENT – RAIL



# NTS MAGNET PLACEMENT – RAIL



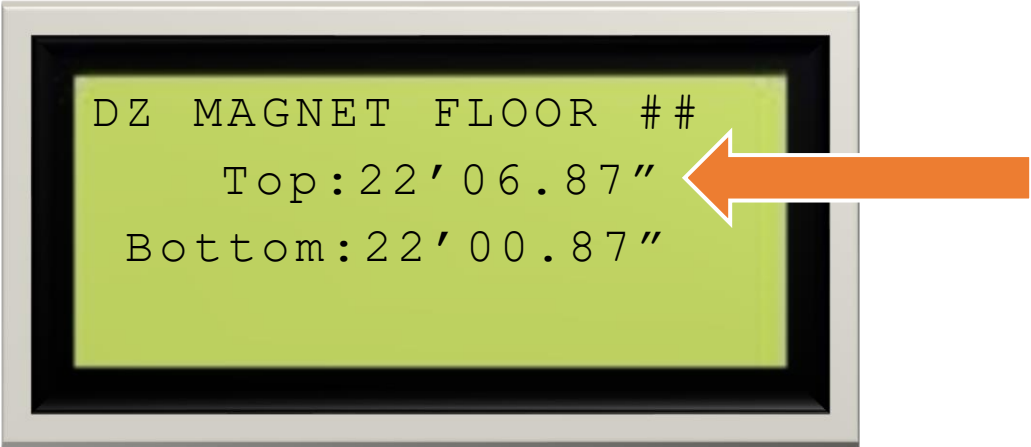


# SLIDE DISTANCE DETERMINATION PROCEDURE FOR ETS MAGNET PLACEMENT

# PROCEDURE

## DET Magnet Placement

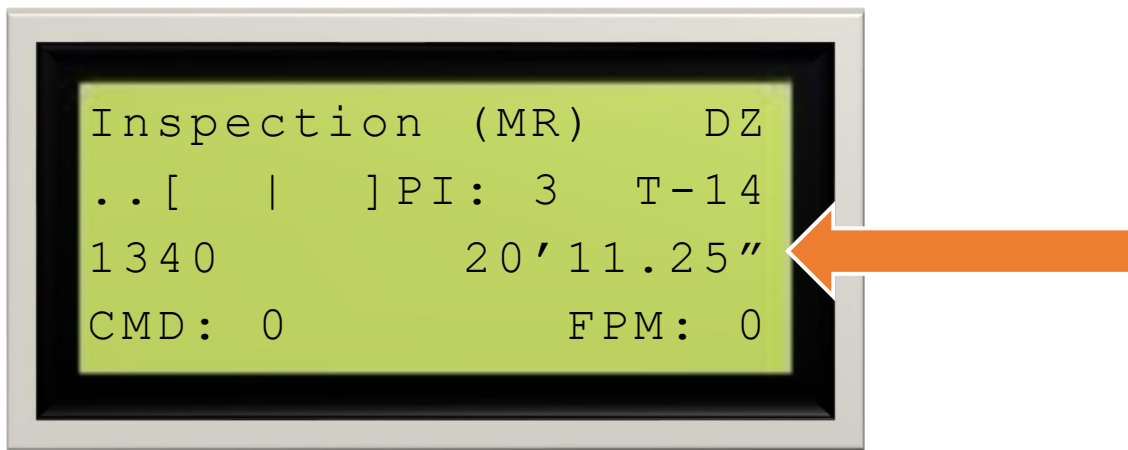
1. Install the DET magnet approx. 2' from the lower terminal landing DZ magnet.
2. Perform the Learn function (see “*Learning the Hoistway*” section). The hoistway has to be learned in order to run the car at full Contract Speed.
3. After the learn is complete, run the car from the cartop inspection station above the DET magnet. Remove the magnet and run the car up to the next door zone above the bottom terminal landing. This will allow the car to come to an emergency stop without going onto the buffer.
4. Position the DET magnet on the tape opposite the DZ magnet.
5. Go to MAIN MENU | STATUS | MAGNETS | DZ MAGNET ## and scroll to the floor the car is currently at. Record the TOP position for the magnet.



Top: \_\_\_\_' \_\_\_\_."

6. Run the car up to a door zone far enough above the magnet for a full speed run.

7. From the machine room, enter a car call to the bottom terminal landing, sending the car down towards the DET magnet at Contract Speed (MAIN MENU | DEBUG | ENTER CAR CALLS).
8. As the car passes the DET switch it will get a "F81:DETS Overspeed" fault and perform an emergency stop.
9. When the car comes to a complete stop, quickly switch the car to Inspection (MR) before the controller resets and tries to correct itself.
10. Record the position the car is currently stopped at from the home screen of the LCD.



E-Stop Position: \_\_\_\_' \_\_\_\_."

11. Subtract the position from where the car stopped at (Step #10) from the known position of the DET magnet (Step #5). This will be the actual slide distance of the car.

Slide Distance (SD): \_\_\_\_' \_\_\_\_"

12. Position the DET magnet no less than the minimum distance (refer to the *Minimum Distance Equation*). Measure from the middle of the terminal landing DZ magnet up to the top of the DET magnet.

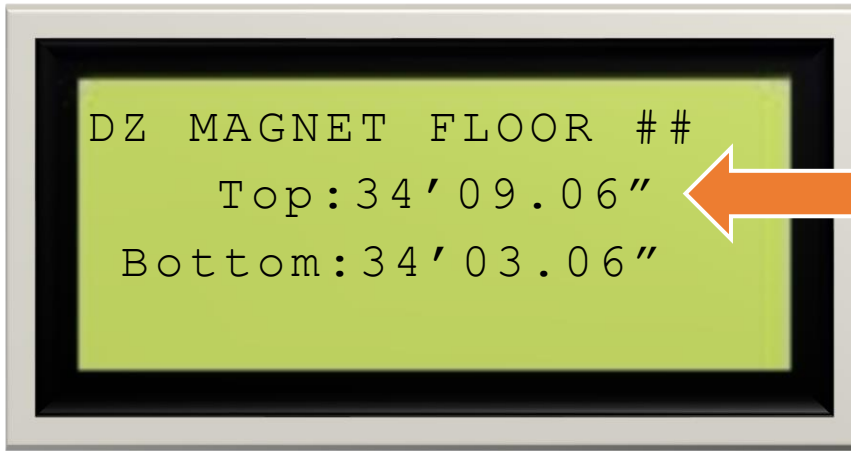
NOTE: This distance is the MINIMUM distance to install the DET magnet. The magnet can be placed at a greater distance but verify that it is not outside the highest speed profile's slowdown distance.

### UET Magnet Placement

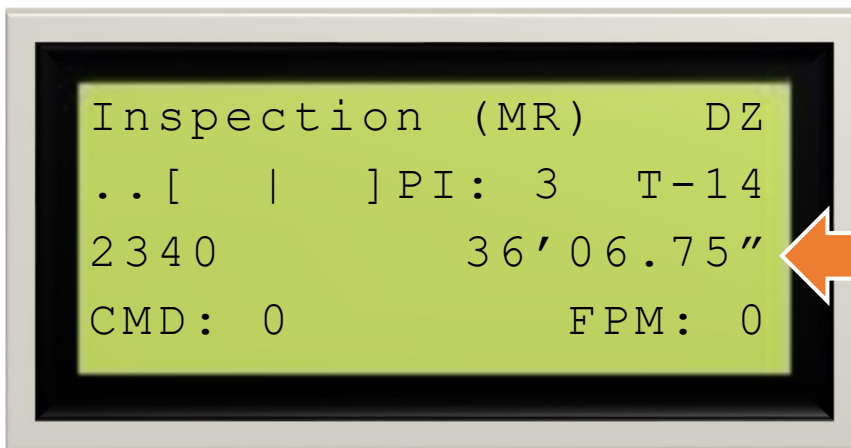
1. After placing the DET magnet in the correct location, run the car to just above the newly placed magnet.
2. Turn on Dip Switch #2 (Dip A) and switch the car to Normal.
3. Go to MAIN MENU | SETUP | LEARN MODE COMMANDS | HOMING RUN. Press enter and select YES.
4. When the car stops at the new DET position (IOs 511/512 = OFF) press the left arrow button once and scroll down to MOVE TO BOTTOM. Press enter and select YES.
5. When the car stops at the bottom door zone, turn Dip Switch #2 (Dip A) to OFF and enter a car call to the floor below the top terminal landing.
6. From CT Inspection, run the car up just below the UET magnet and remove it.
7. Run the car down to the next door zone below the terminal landing and position the UET magnet on the tape opposite the DZ magnet.
8. Go to MAIN MENU | STATUS | MAGNETS | DZ MAGNET ## and scroll to the floor the car is currently at. Record the TOP position for the magnet.

Top: \_\_\_\_' \_\_\_\_."

9. Run the car down to a door zone far enough below the magnet for a full speed run.



10. Enter a car call to the top terminal landing send the car up towards the UET magnet at Contract Speed (MAIN MENU | DEBUG | ENTER CAR CALLS).
11. As the car passes the UET magnet it will get a "F80:UETS Overspeed" fault and perform an emergency stop.
12. When the car comes to a complete stop and the fault "A64: Stop No DZ" appears on the screen, quickly switch the car to Inspection (MR) before the controller resets and tries to correct itself.
13. Record the position the car is currently stopped at from the home screen of the LCD.



E-Stop Position: \_\_\_\_' \_\_\_\_."

13. Subtract the position from where the car stopped at (from Step #12) from the known position of the DET magnet (from Step #8). This will be the actual slide distance of the car.

Slide Distance: \_\_\_\_' \_\_\_\_"

14. Position the UET magnet no less than the slide distance measured from the middle of the terminal landing DZ magnet down to the top of the UET magnet.

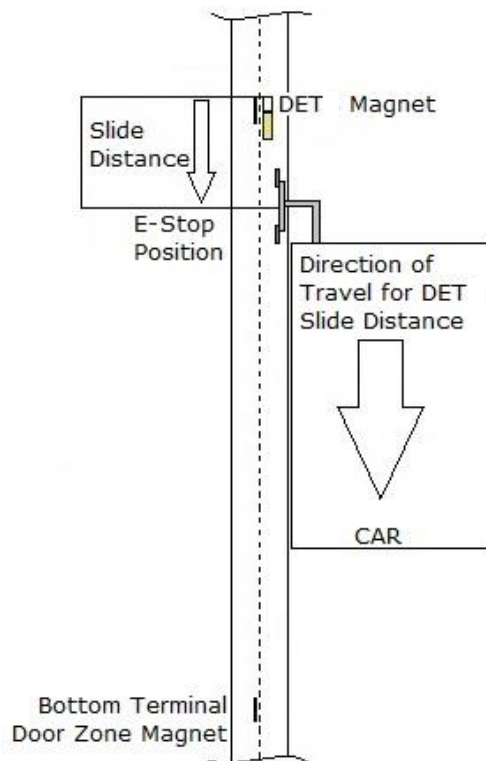
NOTE: This distance is the MINIMUM distance to install the UET magnet. The magnet can be placed at a greater distance but verify that it is not outside the highest speed profile's slowdown distance.

Once both magnets are placed in the proper location move the car to the bottom terminal landing and perform the learn function again (see "*Learning the Hoistway*" section). This will save the new locations of the ETS magnets.

# ETS Slide Distance Overview

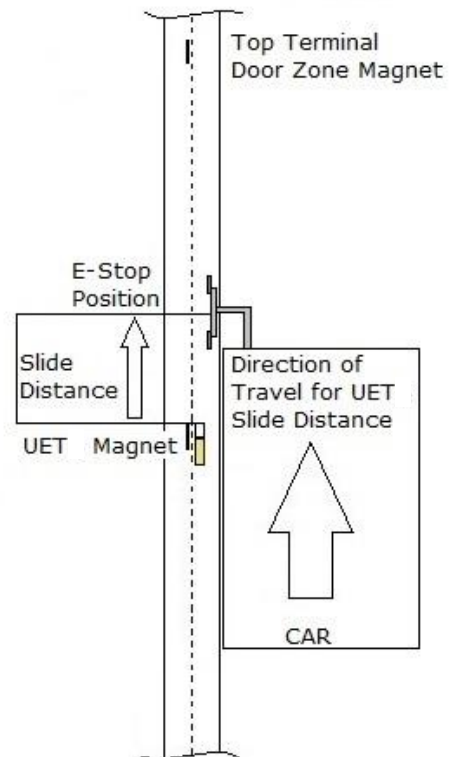
## DET Illustration

Once the distance is determined, move the DET magnet at the bottom terminal landing to a distance equal to or greater than the one calculated in the "DET Magnet Placement" procedure.



## UET Illustration

Once the distance is determined, move the UET magnet at the top terminal landing to a distance equal to or greater than the one calculated in the "UET Magnet Placement" procedure.



# MANUAL ETS and FINAL LIMIT SWITCHES

---

## ETS Switches

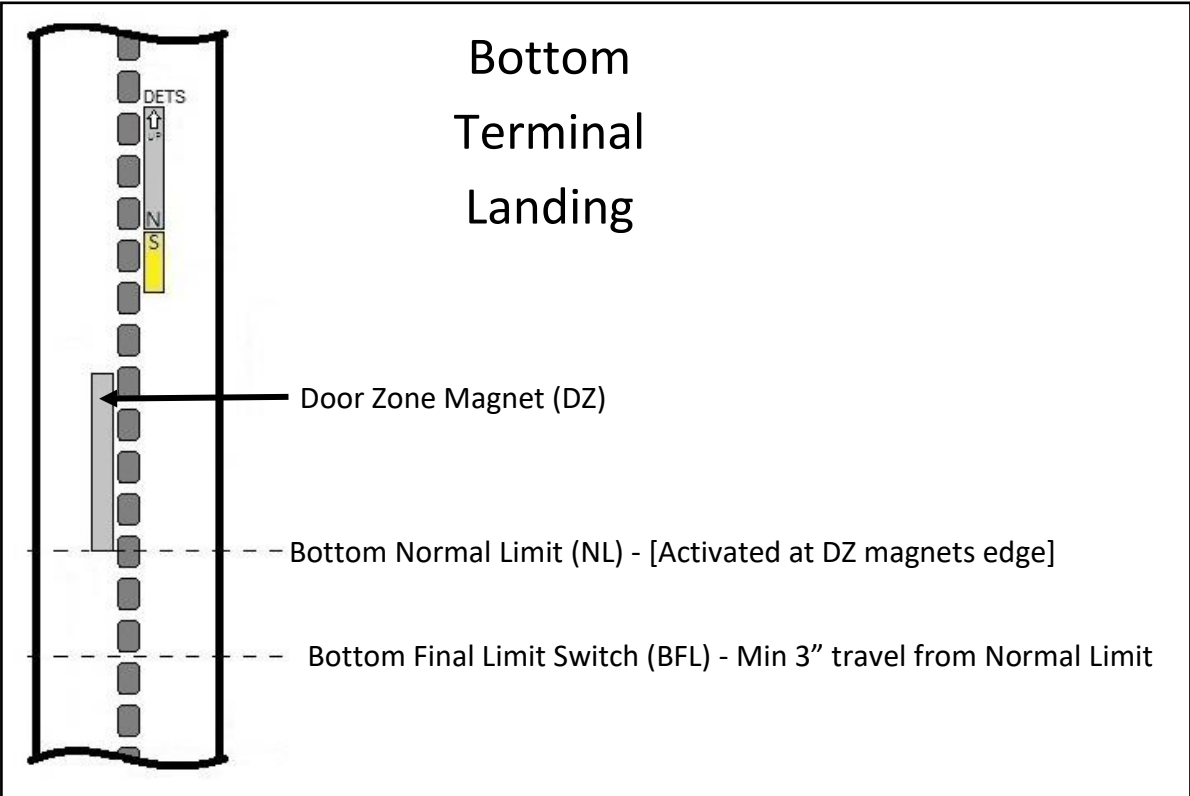
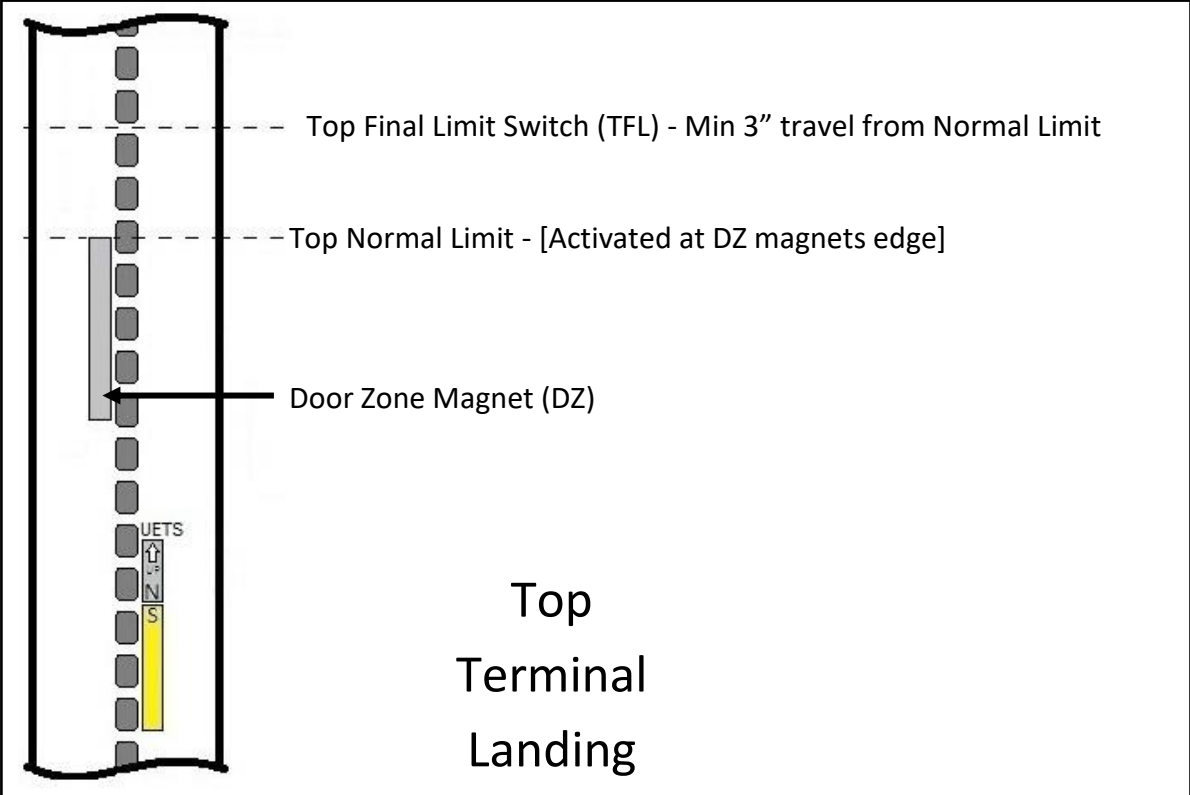
1. The UET and DET are Normally Closed (NC) 24vdc switches.
2. The distance measured from the door zone magnet to the switch is the same as the ETS magnet placement.
3. Ensure the switch inputs stay low the entire time the car is within the terminal landing Door Zone.
4. Install both switches so that if the car actuates the final limit switch the cam will still have the appropriate UET or DET switch actuated.
  - a. UET: this switch is located at the top terminal landing. It must be installed within the programmed slowdown distance to ensure that the controller has already started to slow down by the time the switch is actuated, or a “*UETS Overspeed*” fault can occur.
  - b. DET: same as UET, but at the bottom terminal landing. This switch *should be placed at a distance measured up from the center of the bottom terminal landing magnet.*

## Final Switches

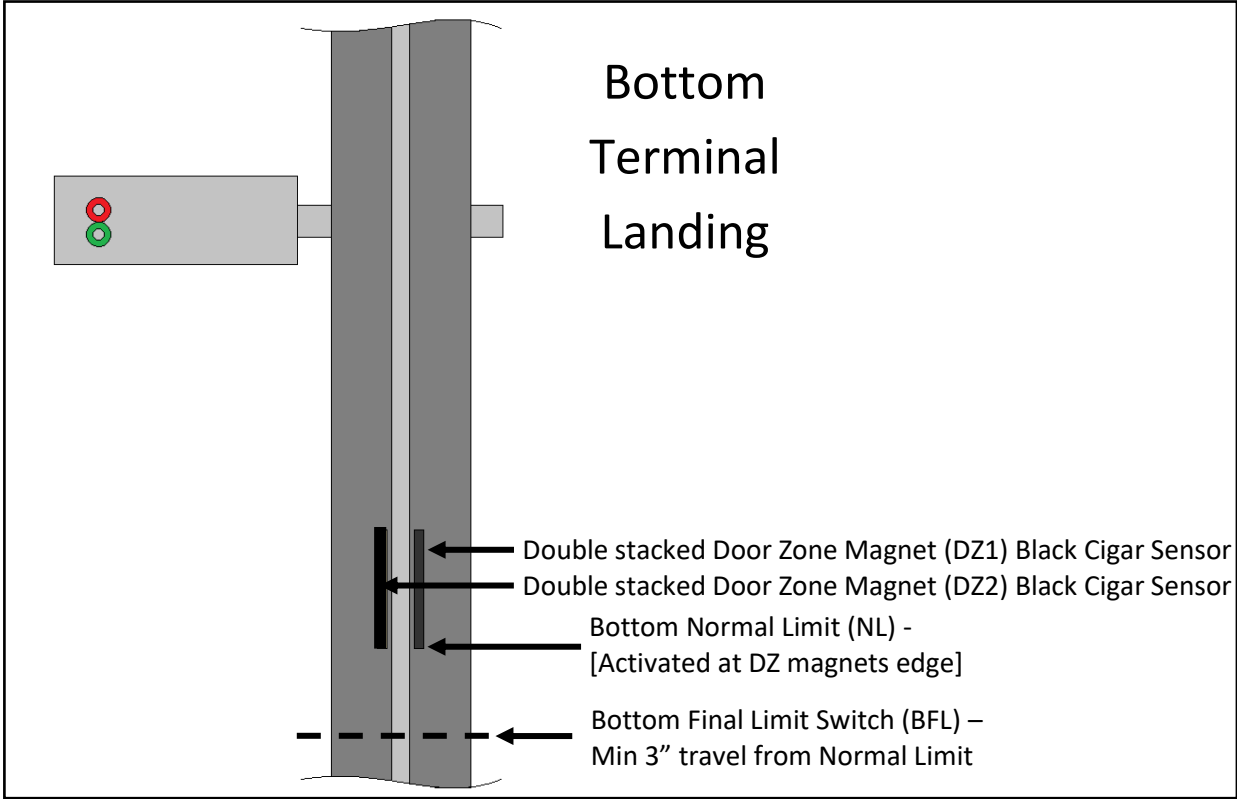
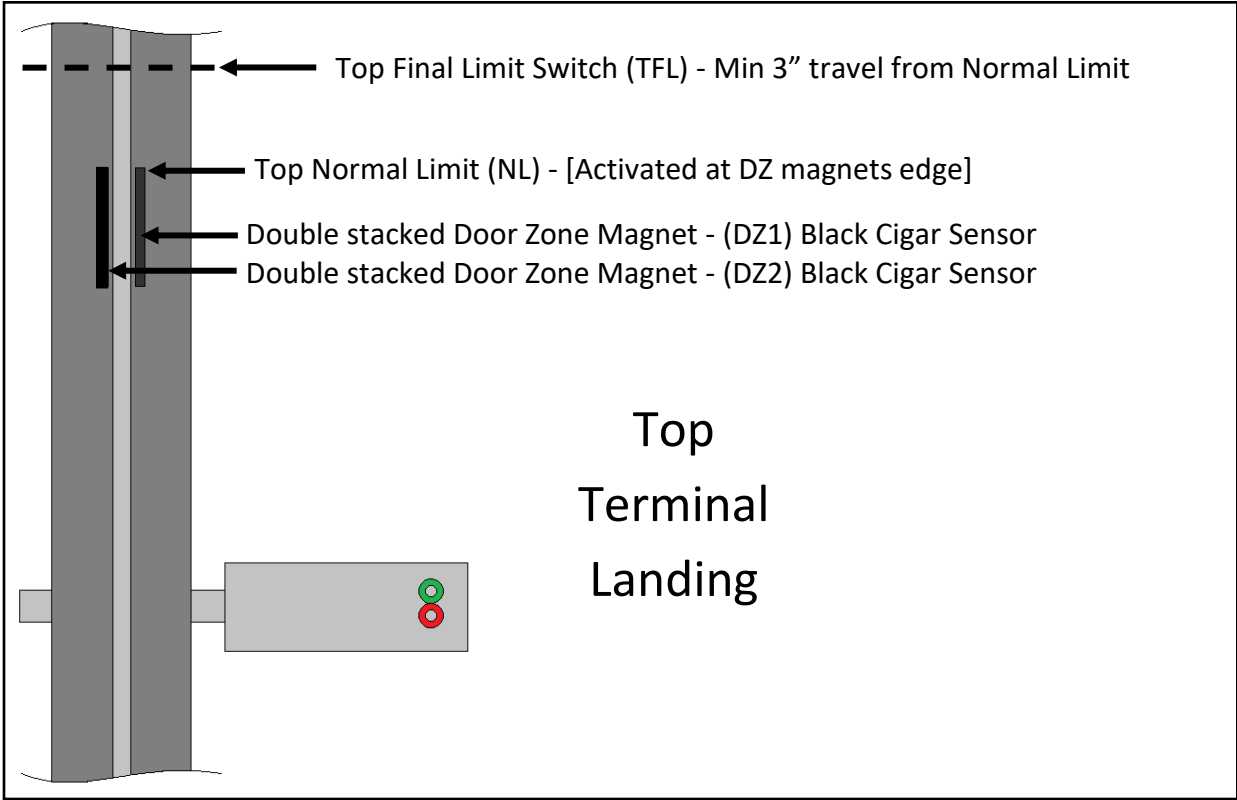
1. The Final Limit switches must be installed in the safety string. Place the Final switches after the UET and DET switches above (top terminal) and below (bottom terminal) Door Zone Magnets.
2. The Finals should be installed with a minimum run distance of 3” from when the terminal DZ magnet Normal Limit is flagged at the bottom edge of the magnet.
3. Refer to the *Final Switch Placement* illustrations on the following pages for tape or beam installations.



# FINAL SWITCH PLACEMENT - TAPE



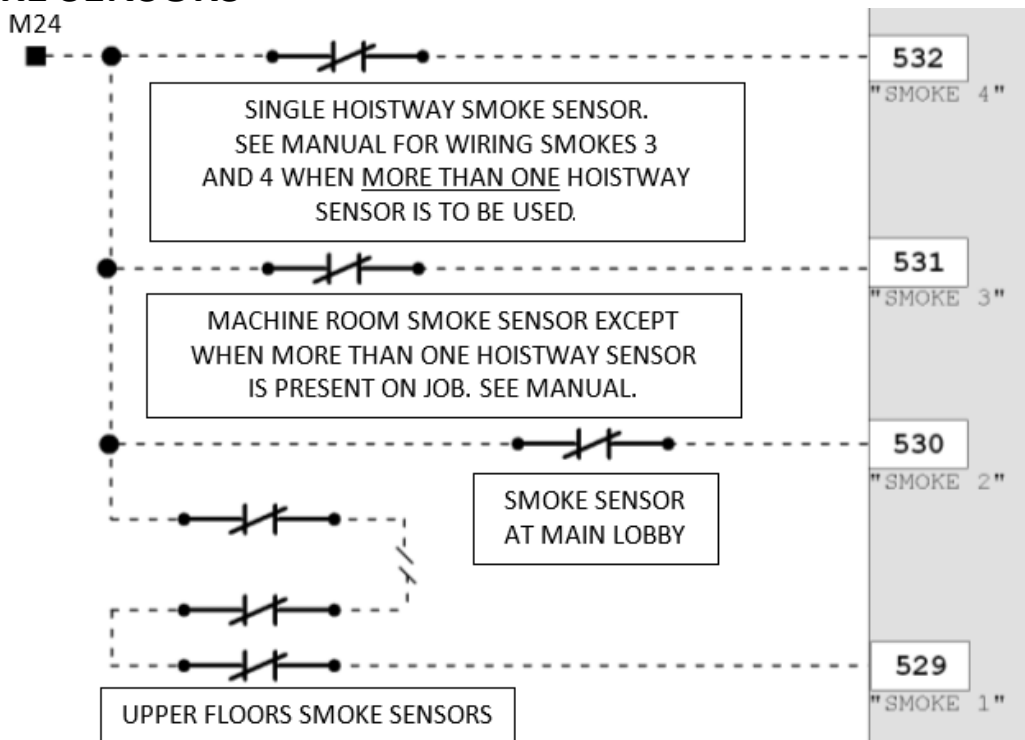
# FINAL SWITCH PLACEMENT – RAIL



# SMOKE SENSORS, SHUNT, & LOAD WEIGHING

# SMOKE SENSOR SETUP

## SMOKE SENSORS



Smartrise controllers include four inputs for connecting smoke sensors. In a 4-Smoke setup activation of any smoke sensor will put the controller in Fire Recall operation. In a 3-Smoke setup only Smokes 1 & 2 will put the controller in Fire Recall operation.

The inputs are: Smoke 1, Smoke 2, Smoke 3, and Smoke 4. See Sheet 2 of the job prints to determine which SRU board input is configured for each smoke designation.

During installation, the smoke inputs should temporarily be jumped to M24 until such time as the smoke sensors are installed. The jumper must be removed when the smoke sensor is connected. Leave the jumper in place on any smoke input which will not be used.

Smartrise recommends wiring and programming the smoke inputs in the following manner for proper compliance with A17.1/B44 safety code. The following table illustrates the sensor number, the location the sensor is installed and where the car goes to during activation.

Input	Location of Sensor(s)	Sends Car to:	Flash Fire Hat:
<b>Smoke 1 (529)</b>	All floors <u>except</u> the Main Level	Main Level	No (not programmable)
<b>Smoke 2 (530)</b>	Smoke sensor at Main Level	Alternate Level	No
<b>Smoke 3 (531)</b>	Machine room and/or hoistway	Main Level	Yes
<b>Smoke 4 (532)</b>	Machine room and/or hoistway	Alternate Level	Yes

**Smoke 1** – Smoke 1 will never flash the in-car fire lamp.

This input should connect to the smoke sensors of all the floors served by the elevator except the Main Level where the Fire Phase 1 key switch is located.

Wire the smoke sensors from all the other floors except the Main Level in series and connect them to Smoke 1. Do not wire the smoke sensor(s) located at the Main Level to Smoke 1.

Smoke 1 should be programmed to send the car to the Main Level since its activation indicates fire at another floor.

**Smoke 2** – Smoke 2 should be programmed not to flash the in-car fire lamp.

This input should connect only to the smoke sensor(s) located at the Main Level.

Do not wire any other smoke sensors to this input.

Smoke 2 should be programmed to send the car to the Alternate Level since its activation indicates a fire at the Main Level.

### **Smoke 3 / Smoke 4** – Machine room and hoistway smoke sensors.

- ❖ When there is only one machine room and one hoistway smoke sensor, Smoke 3 is used for the machine room and Smoke 4 is used for the hoistway smoke sensor.
- ❖ When more than one hoistway sensor is installed, it is possible that the activation of one sensor may require the car to be sent to the Main Level while the activation of another sensor would send the car to the Alternate Level. Smoke 3 & Smoke 4 can be wired in series to multiple sensors to accommodate the proper recall level based on the physical location of the sensor in question.
- ❖ Refer to the Smoke Sensor Setup Illustration for an example of proper wiring of smoke sensors based on location.

**Smoke 3** – Smoke 3 should be programmed to flash the in-car fire lamp.

This input should connect to any machine room or hoistway smoke sensor whose activation sends the car to the Main Level.

If the machine room is located away from the Main Level (e.g. on the roof), its smoke sensor should be connected to this input.

Consult your local code to determine which hoistway smoke sensors should send the elevator to the Main Level and connect them to this input.

**Smoke 4** – *Smoke 4 should be programmed to flash the in-car fire lamp.*

This input should connect to any machine room or hoistway smoke sensor whose activation sends the car to the Alternate Level.

If the machine room is located at the Main Level, its smoke sensor should be connected to this input to send the elevator to the Alternate Level.

Consult your local code to determine which hoistway smoke sensors should send the elevator to the Alternate Level and connect them to this input.

## **Programming Smoke Sensor Floor Recalls**

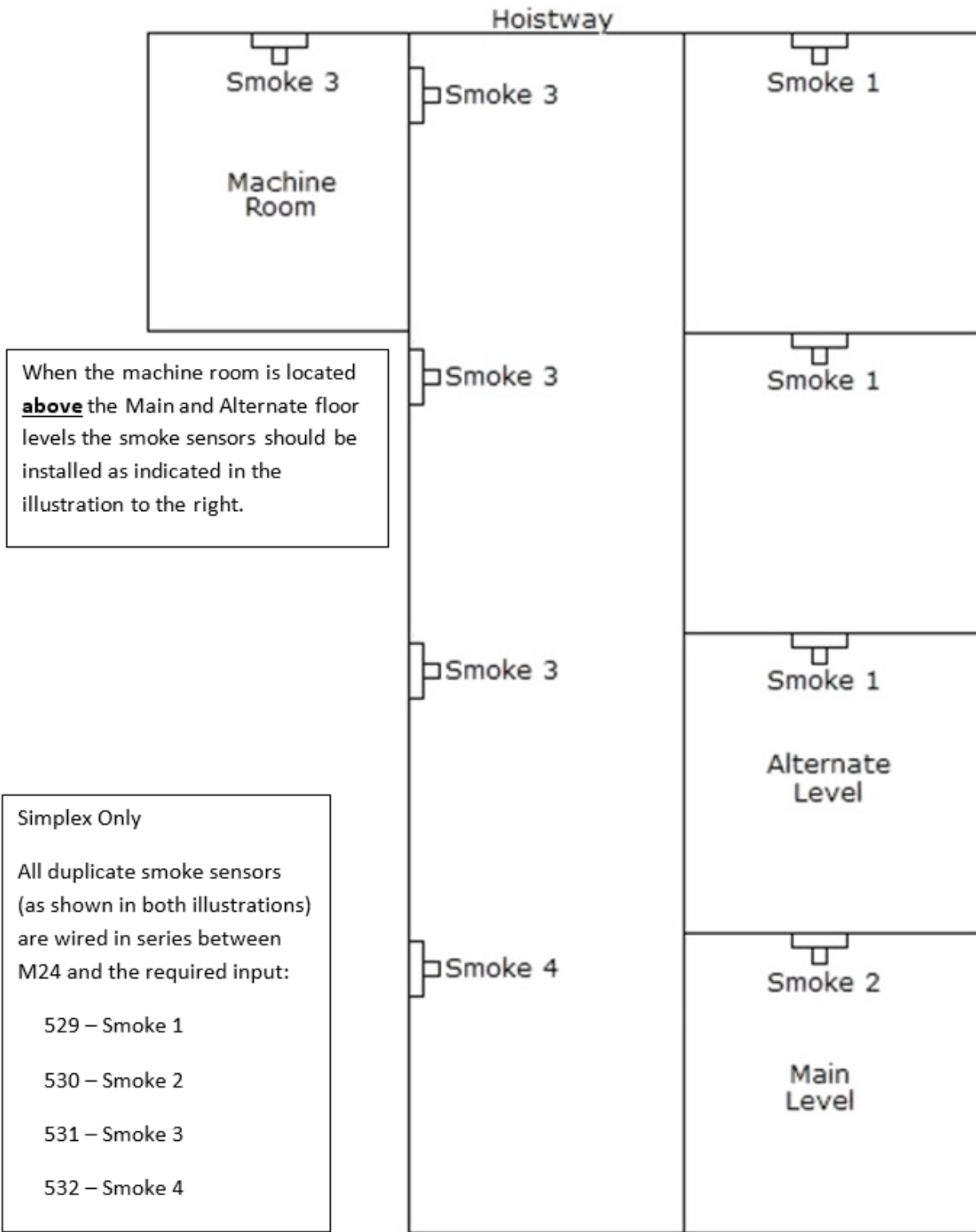
Go to **MAIN MENU | SETUP | FIRE/EARTHQUAKE**. For each smoke sensor (1-4) - Enter the floor location the car is to be recalled to once that sensor is activated.

**Note: The Fire Key is the same as Smoke 1.**

## **Programming Smoke Fire Hat Flashing**

If the code requires a specific smoke to flash the fire hat in the Car Station and Hoistway, go to **MAIN MENU | SETUP | FIRE/EARTHQUAKE | FLASH ON SMOKE 2~4**, set the smoke sensor option to “YES” and then save it.

# SMOKE SENSOR SETUP ILLUSTRATION – UPPER LEVEL MACHINE ROOM



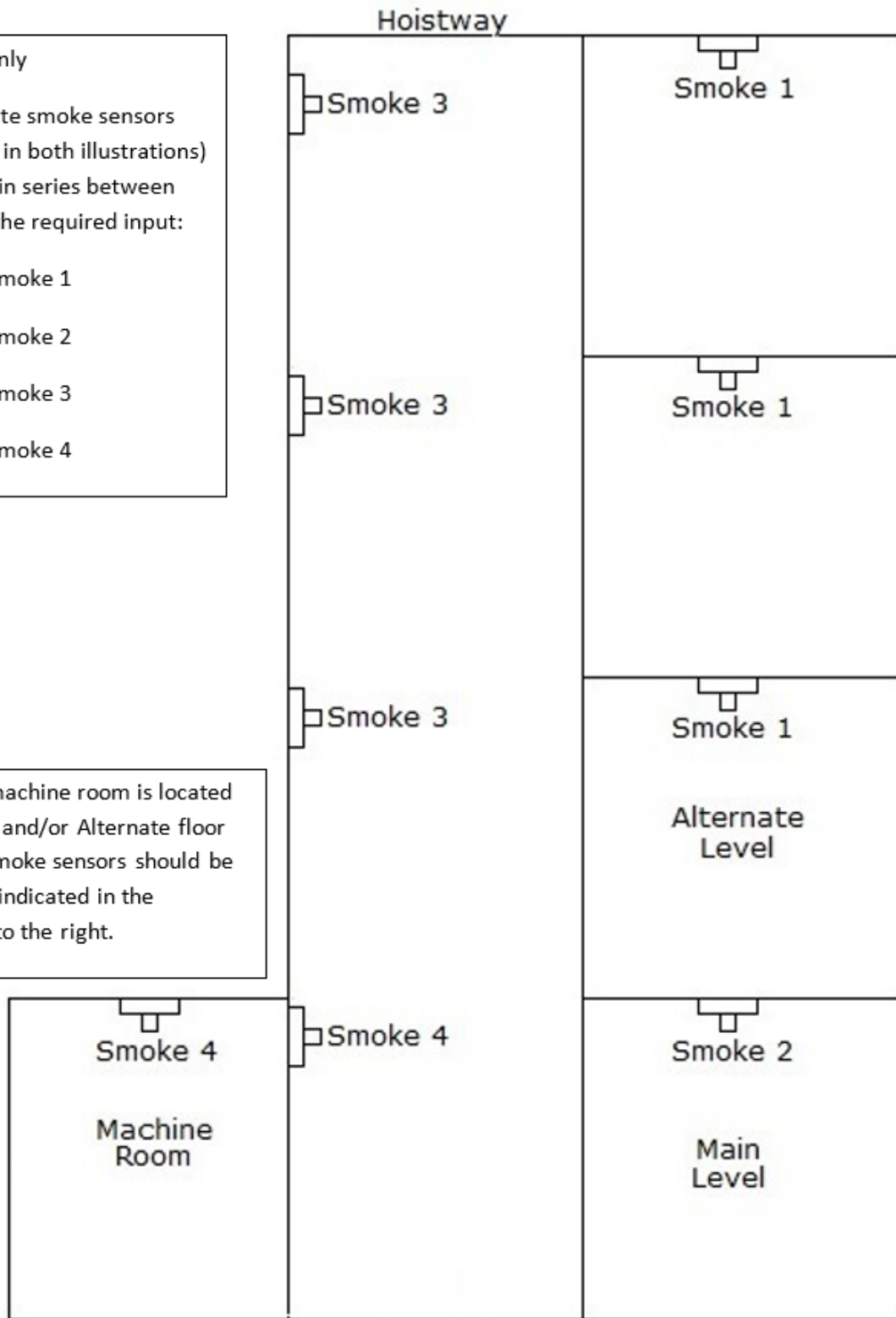
# SMOKE SENSOR SETUP ILLUSTRATION – LOWER LEVEL MACHINE ROOM

Simplex Only

All duplicate smoke sensors (as shown in both illustrations) are wired in series between M24 and the required input:

- 529 – Smoke 1
- 530 – Smoke 2
- 531 – Smoke 3
- 532 – Smoke 4

When the machine room is located **at** the Main and/or Alternate floor levels the smoke sensors should be installed as indicated in the illustration to the right.





# SHUNT OPERATION

---

The Shunt Output is designed to kill the main power to the controller in case of a fire in the Machine Room. The output on the SRI board allows the controller to activate an external “Shunt Disconnect” device after the car has moved to the recall floor and opened its doors.

1. Smoke Sensor activates.
2. Car(s) move to programmed recall floor and open the doors.
3. Shunt Output activates and opens the Shut bypass switch, killing power to the main disconnect.

**NOTE: Battery Lowering Instructions: The ML1/ML2 line (Sheet 3) MUST be ran through the shunt disconnect so that the BLD won't power up when the Shunt disconnect trips. Failure to do this will cause high voltage to be present even after the main power is cut.**

## 3 Smoke – Group Shunt Setup

The Shunt Output for a duplex setup is two-fold: both the car and group SRU need to have parameters set to activate the Shunt Operation.

The Shunt input is on the group SRU board via Smoke 3 (IO 531) and the output for the disconnect is on the individual car's SRU board, since activation is dependent on when the car has moved to the recall floor and opened its doors.

1. Group Binary Parameter (**MAIN MENU | DEBUG | BINARY PARAMETERS**)
  - a. 00-018.0 = “YES”
  - b. This changes the smokes to the following:
    - i. Smoke 1 sends car to Main Floor
    - ii. Smoke 2 sends car to Alternate Floor
    - iii. Smoke 3 activates input for Shunt Trip operation
    - iv. Smoke 4 flashes the In-Car Fire Lamp
2. Car Binary Parameter (**MAIN MENU | DEBUG | BINARY PARAMETERS**)
  - a. 13-172.5 = “YES”

## 3 Smoke – Simplex Shunt Setup

1. Car Binary Parameter (**MAIN MENU | DEBUG | BINARY PARAMETERS**)
  - a. 13-172.5 = “YES”
  - b. When this parameter is set it changes the function of the smoke inputs to the following:
    - i. Smoke 1 sends car to Main Floor

- ii. Smoke 2 sends car to Alternate Floor
- iii. Smoke 3 activates output for Shunt Trip disconnect after recall operation
- iv. Smoke 4 flashes the In-Car Fire Lamp

NOTE: Smoke 3 and Smoke 4 have no effect unless either Smoke 1 or Smoke 2 are active. When parameter 13-172.5 is set to “NO” the smokes behave as a 4–Smoke system. This feature was added in version 2.32b.

## 4 Smoke – Simplex/Group Shunt Setup

1. Car Binary Parameter (**MAIN MENU | DEBUG | BINARY PARAMETERS**)
2. The following parameters activate the programmed Shunt Trip Output when the car has completed Phase 1 recall and has opened its doors at the recall level. The Shunt Trip Output is only activated if the specified smoke sensor is active:
  - a. Shunt Trip on Smoke 1 – 00-088.0 = “YES”
  - b. Shunt Trip on Smoke 2 – 00-088.1 = “YES”
  - c. Shunt Trip on Smoke 3 – 00-088.2 = “YES”
  - d. Shunt Trip on Smoke 4 – 00-088.3 = “YES”

NOTE: These bits are ignored if Binary Parameter **13-172.5** = “YES” (3-Smoke Setup – Simplex or Group).

## LOAD WEIGHING

---

Traction systems occasionally use a load weighing system that monitors the weight of the car. The following shows the definitions of the inputs that the Smartrise SRU uses for the various load weighing devices.

1. **Overload** – this input will ignore hall and car calls until the load is lightened.
2. **Full Load** – this input will still answer car calls but ignore hall calls until load is lightened.
3. **Light Load** – this input is used for anti-nuisance purposes. This input will allow the controller to cancel multiple car calls as long as the light load is active. The amount of calls accepted can be changed in the parameters.

***If you don't have a load weighing device installed but your system has the inputs programmed, don't wire any of the inputs and the car will operate as if on light load.***

# EMERGENCY POWER & SAFETY STRING

# EMERGENCY POWER

---

The Emergency Power option on the Smartrise controller allows 1 or more cars to run on a generator during power outages. The following shows the definitions of the inputs that the Smartrise SRU uses for Emergency Power:

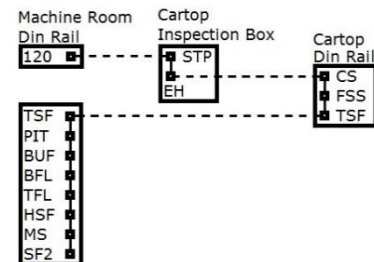
1. **On Emergency Power** – This input tells the controller that the car is on Emergency Power. When this input is active the controller will stop the car at the closest landing and open the doors until the Generator Up to Speed is active.
2. **Generator Up to Speed** – This input tells the controller that the generator is supplying the power to operate the car(s). When this input is active the car will go into normal operation or if selected by the group board (duplexes only).
3. **Pre-Transfer** – This input is used for changing *from* generator *to* normal power. When this input is active the controller will send the car to the programmed recall landing and open the doors.

# SAFETY STRING DESCRIPTION

---

The Safety String is a SERIES based circuit where any open switch will cause the controller to be inoperative. Wire the Traveler and Safety String to the appropriate terminals using the provided drawings. The Safety String is designed to:

1. Operate on 120vac.
2. Pass through a customer installed Stop Switch and a series of safety switches (buffer, pit, hatch, finals, machine room stop switch, etc.), the SF2 relay on the Cartop and through the Machine Room SF1 relay when commanded.
3. Stops the car immediately if any switch is opened during operation.
4. For Emergency Situations: The Safety String is bypassed by jumping SF1 to 120, allowing the car to run as if the safety circuitry is intact.
5. Hydros – Provides power to the Valve Interface Board (COM) and Fault contactor.
6. Traction – Provides power to the M, B1 & B2 contactors.



# SAFETY STRING TROUBLESHOOTING

---

The first step in troubleshooting the Safety String is to determine:

1. Do you have 120vAC at terminal SF2 on the machine room DIN rail?
2. Are there any active faults?
3. Are the proper relays or contactors functioning?

Safety String open:

1. Start by measuring the safety string at the TSF terminal on the machine room DIN rail.
  - a. If it measures 120vAC then the open is either in the hoistway or machine room. Check the PIT, Buffer, Bottom or Top Final switch.
  - b. If it measures less than 70vAC then the open is on the cartop. Check the cartop stop switch, car safeties, escape hatch or fire stop - second pole switch.

# DOOR OPERATOR GENERAL INSTALLATION

MANUAL OPEN/CLOSE – Command the front or rear doors to open or close (nudge) from any Smartrise station by using MAIN MENU | SETUP | DOOR SETUP | MANUAL OPEN & CLOSE. However, the controller must be in Inspection Mode and in a door zone to operate. You may get a gateswitch fault but that is normal.

# MOVFR DOOR OPERATOR

**NOTE: Verify that the voltage supplied to the door operator from breaker DR in machine room matches the actual supply voltage (120vac / 240vac) for the door operator before applying power.**

Remove the Temporary Gate switch jumper when installing the Gate Switch circuit.

Remove Temporary DPM jumper at Cartop Input 519 when making permanent DPM connection from Door Operator. If the DPM is not used then you can jump it to the Gate Switch terminal. Check provided drawings for correct wiring.

A photoeye may be used as a separate input to the cartop controller or wired into the door operator. This will need to be installed for the doors to operate correctly. If a photoeye is not used then jump out the PHE Input to C24 (refer to provided drawings for proper Input terminal).

Photoeyes can have main power of 24vdc or 120vac.

For 24vdc attach to C24 and REF.

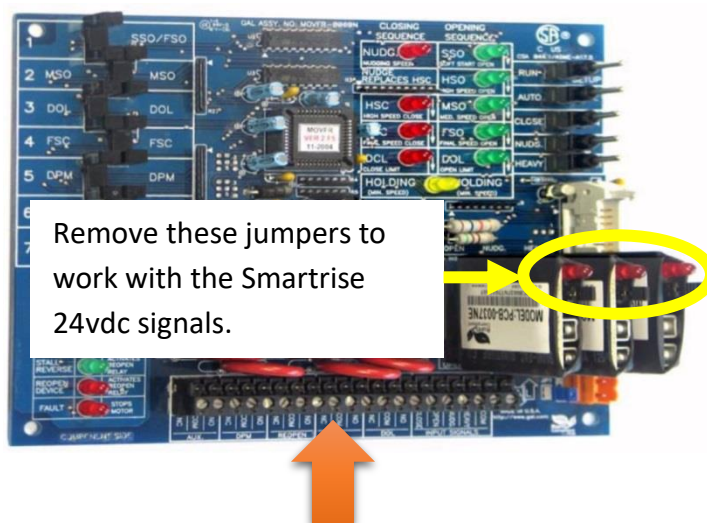
For 120vac attach to 120 and N terminals. Note: Never connect a 120vac photoeye to the terminals on the SRU board. **THE SRU TERMINALS OPERATE ON 24VDC ONLY.**

The normally closed contact (NC) can be connected between the door operator “reopen” terminal and the PHE Input terminal or, if door operator doesn’t support a PHE, then connect a jumper between C24 and the PHE Input terminal.

Push DIP Switch #3 (third from the top) to the ON position. This bypasses door operation and hall calls which will be checked later in this procedure.

The MOVFR door operator requires jumpers to be removed when operated by the low voltage from the Smartrise SRU. See the following figure for jumper location.

MOVFR Control Board



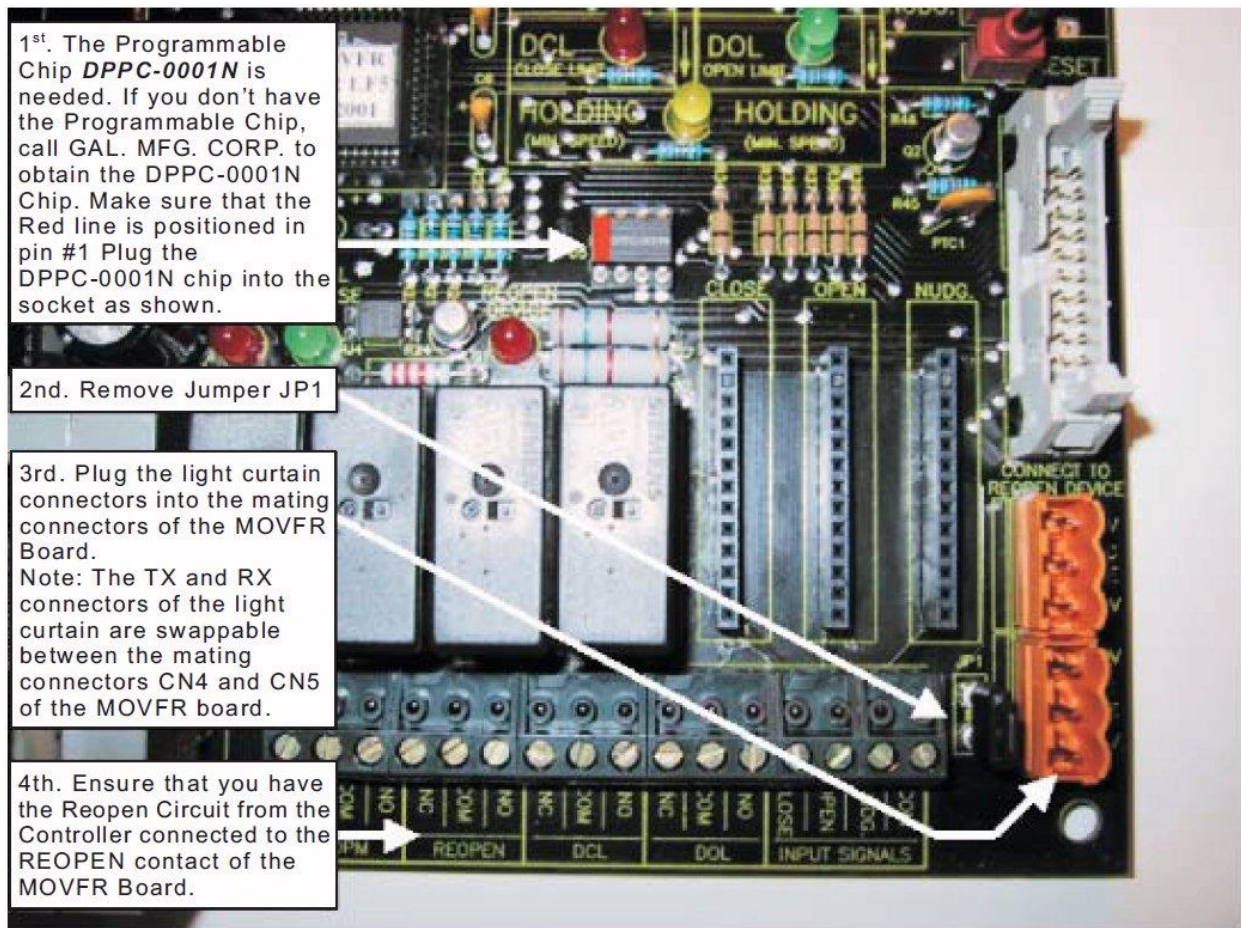
**CAUTION: MAKE SURE YOU DON'T OVERTIGHTEN THE SCREW TERMINALS ON THE MOVFR TERMINAL STRIP. DAMAGE TO THE CONTACT PIN CAN OCCUR.**



# MOVFR DOOR OPERATOR – G.A.L. CERTIFIED PHE

To use a G.A.L. certified light curtain on the MOVFR door operator you must follow the 4 steps listed below:

1. Insert the G.A.L. programmable chip in socket U5 (DPPC-0001N) as shown below. If you don't have this chip then you must call G.A.L. and get it.
2. Remove jumper JP1 located at the end of the terminal strip.
3. Plug the G.A.L. light curtain plug into the orange socket next to the JP1 jumper.
4. IMPORTANT! Connect the PHE input on the SRU board to the REOPEN terminal on the MOVFR. Make sure the REOPEN COM is connected to C24.





## IPC DOOR OPERATOR CONTROL MODEL D3000

---

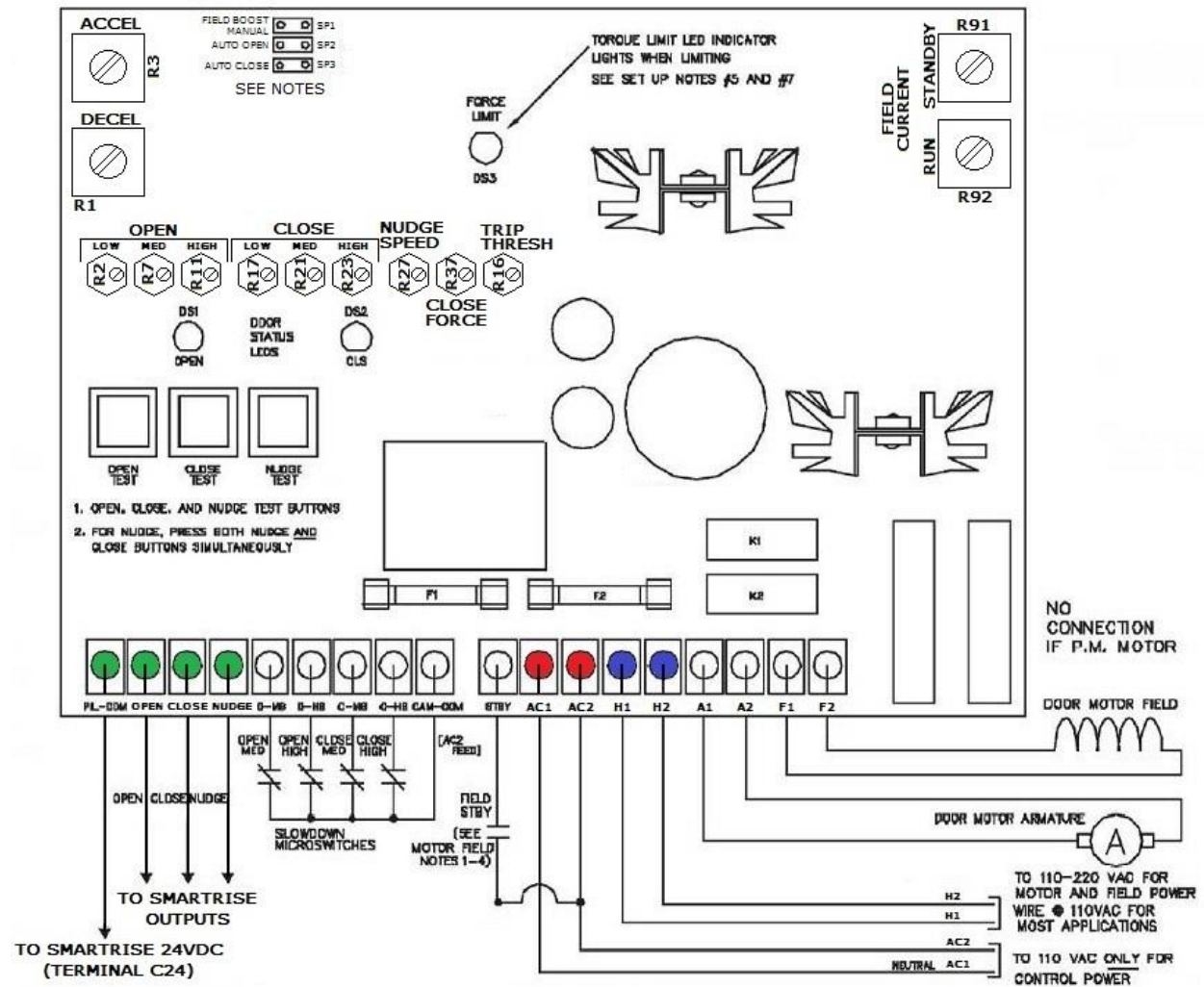
The IPC D3000 Door Operator Control Board is designed as an interface control board that operates on the low voltage signals supplied by the Smartrise SRU. Refer to Sheet 11 of the Smartrise drawings for correct wiring connections.

### D3000 WARNINGS AND NOTES:

1. AC1-AC2 INPUT POWER IS 115VAC. DO NOT OPERATE AT ANY HIGHER VOLTAGE.
2. *NEVER APPLY A CAPACITIVE LOAD TO THIS ASSEMBLY. NEVER ADD ANY CAPACITORS TO THE MOTOR OR TO THE FIELD FOR ANY PURPOSE.*
3. DANGER! CAPACITORS STAY CHARGED FOR 10 MINUTES AFTER POWERING OFF. ALLOW SUFFICIENT TIME BEFORE SERVICING.
4. THIS CIRCUIT OPERATES WITH LETHAL VOLTAGES AND MAY CAUSE SERIOUS INJURY OR DEATH IF MISAPPLIED.
5. CONTROL POWER {AC1-AC2} MUST BE APPLIED BEFORE MOTOR AND FIELD POWER {H1-H2}.
6. DO NOT GROUND ANY CONNECTION EXCEPT AC1 AT ANY TIME.
7. TEST FIELD AND ARMATURE FOR INFINITE RESISTANCE TO GROUND. USE A "MEGGER" IF POSSIBLE.
8. INPUT POWER MUST BE FUSED EXTERNALLY FOR 8 AMPS.
9. DO NOT PLACE ELEVATOR IN SERVICE UNTIL THE SETUP PROCEDURE HAS BEEN COMPLETED AND DOOR OPERATION COMPLETELY TESTED.

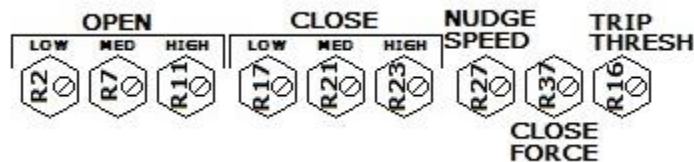
# MOTOR FIELD MANUAL / AUTO JUMPER SETTINGS

- SP1 – “FIELD BOOST MANUAL” – CONNECT THIS JUMPER ONLY TO MAKE THE FIELD FOLLOW THE EXTERNAL STANDBY / RUN INPUT.  
IE: RUN = STANDBY CONTACT DE-ENERGIZED; STANDBY = STANDBY CONTACT ENERGIZED
- SP2 – “AUTO OPEN” – IN THIS POSITION ONLY – FIELD WILL AUTOMATICALLY FOLLOW THE RUN SETTING IN OPEN DIRECTION AND DEFAULT TO THE STANDBY SETTING IN CLOSE.
- SP3 – “AUTO CLOSE” – IN THIS POSITION ONLY – FIELD WILL AUTOMATICALLY FOLLOW THE RUN SETTING IN CLOSE DIRECTION AND DEFAULT TO THE STANDBY SETTING IN OPEN.
- INSTALL BOTH SP2 – “AUTO OPEN”- AND SP3 – “AUTO CLOSE” – FOR FULL AUTOMATIC OPERATION  
IE: FIELD WILL FOLLOW THE RUN SETTING WHENEVER THE OPEN OR CLOSE PILOTS ARE ENERGIZED. WHEN BOTH PILOTS ARE DE-ENERGIZED, FIELD WILL FOLLOW THE STANDBY FIELD POT SETTING.



## D3000 CONTROL ADJUSTMENTS

1. DOOR OPEN HIGH – *OPEN HIGH AND OPEN MED CONTACTS OPEN*, ADJUST R11 {4 TURN POT}
2. DOOR OPEN MED – *OPEN HIGH CONTACTS CLOSED, OPEN MED CONTACTS OPEN*. ADJUST R7 {4 TURN POT}
3. DOOR OPEN LOW – *OPEN HIGH AND OPEN MED CONTACTS CLOSED*. ADJUST R2 {4 TURN POT}
4. DOOR CLOSE HIGH – *CLOSE HIGH AND CLOSE MED CONTACTS OPEN*. ADJUST R23 {4 TURN POT}
5. DOOR CLOSE MED – *CLOSE HIGH CONTACT CLOSED, CLOSED MED CONTACT OPEN*. ADJUST R21 {4 TURN POT}
6. DOOR CLOSE LOW – *CLOSE HIGH AND CLOSE MED CONTACTS CLOSED*. ADJUST R17 {4 TURN POT}
7. TRIP THRESHOLD – ADJUST R16 FOR REMAINING DOOR FORCE AFTER TRIP {30LBS@EDGE} {4 TURN POT}
8. CLOSE FORCE – ADJUST R37 TO SET POINT AT WHICH THE DOOR TRIPS TO SLOW SPEED/TQ UPON AN OBSTRUCTION {4 TURN POT}
9. NUDGE SPEED – ADJUST R27 TO SET THE NUDGE SPEED {4 TURN POT}



10. ACCEL / DECEL – ADJUST R3 AND R1 TO SET RESPECTIVE ACCEL AND DECEL RATES {1 TURN POT}
11. FIELD CURRENT STANDBY – ADJUST R91 TO SET FIELD OUTPUT VOLTAGE WHEN BOTH OPEN AND CLOSE PILOTS ARE REMOVED. RANGE OF 50 TO 200 VDC – SET TO 50VDC {1 TURN POT}
12. FIELD CURRENT RUN – ADJUST R92 TO SET FIELD OUTPUT VOLTAGE- SET TO 90 – 100 VDC RANGE OF 50 TO 200 VDC {1 TURN POT}



**TURN POTS CLOCKWISE TO INCREASE FORCE, SPEED or RATE**

**WARNING! – DO NOT OVERVOLTAGE MOTOR FIELD – DAMAGE TO CIRCUIT CAN OCCUR! -- GENERALLY ONLY 90 – 120VDC REQUIRED TO OPERATE FIELD AT RUN**

## SET UP INSTRUCTIONS FOR D3000 DOOR OPERATOR

1. INSTALL CONTROL ACCORDING TO IPC HOOK UP DIAGRAM. SET FIELD MANUAL/AUTO JUMPER SETTINGS AS DESIRED. USE 110V FOR "H1-H2" WHENEVER POSSIBLE IF ADEQUATE DOOR PERFORMANCE CAN BE OBTAINED.
2. BEFORE APPLYING POWER, PRESET ALL POTENTIOMETERS AS FOLLOWS:
  - a. 0-HI, 0-MED, C-HI, C-LO to FULLY CCW:
  - b. 0-LO, C-LO, NUDGE SPD., ACCEL/DECEL to MID POSITION:
  - c. C-FORCE and T-THRESH to FULLY CW:
  - d. STANDBY and RUN to ¼ TURN CW.
3. APPLY POWER AND CYCLE DOOR OPEN AND CLOSED. DOOR SHOULD OPERATE ONLY AT SLOW SPEED SINCE MED AND HI POTS ARE ALL THE WAY DOWN.
  - a. ADJUST 0-LO AND C-LO AND CAM SWITCHES FOR A SATISFACTORY FINAL OPEN AND FINAL CLOSE. CHECK FIELD VOLTAGE SETTINGS
  - b. SET STANDBY FOR APPROX 50VDC. RUN FOR APPROX. 90 – 110 VDC.
4. ADJUST THE OPEN MED AND CLOSE MED POTS FOR APPROPRIATE MIDRANGE SPEEDS AND ADJUST THE CAM SWITCHES FOR DESIRED SLOW-DOWN POINTS. AT THIS POINT THE ACCEL/DECEL POTS MAY ALSO BE ADJUSTED TO OBTAIN A QUICK BUT SMOOTH TRANSITION FROM MEDIUM TO SLOW SPEED.
5. ADJUST OPEN HI AND CLOSE HI POTS FOR THE DESIRED MAXIMUM DOOR SPEEDS AND ADJUST THE CAMS FOR PROPER TRANSITION POINTS FROM SLOW TO MEDIUM TO HIGH AND BACK DOWN IN EACH DIRECTION.
6. ADJUST THE ACCEL/DECEL POTS AND FINE TUNE CAM POSITIONS AND SPEEDS FOR THE BEST DOOR PERFORMANCE POSSIBLE. IT MAY BE DESIRABLE TO START THE DOOR DIRECTLY TO MEDIUM OR EVEN HIGH SPEED IF VERY HIGH DOOR PERFORMANCE IS NECESSARY. CHECK FOR SMOOTH OPERATION ON BOTH THE LIGHTEST AND HEAVIEST DOORS IN THE SHAFT. IF THE TORQUE LIMIT LED BUNKS DURING CLOSING AND DOOR "TRIPS", THE ACCEL / DECEL OR TOP SPEED IS SET TOO FAST FOR THE WEIGHT OF THE DOOR AND MUST BE REDUCED.
7. DURING A NORMAL CLOSE (DO NOT OBSTRUCT DOOR). ADJUST CLOSE FORCE POT {R37} CCW UNTIL DOOR "TRIPS" ON ITS OWN {TQ LIMIT LED SHOULD FLICKER}. THEN ADJUST POT ½ TO 1 TURN CW TO ADD HEADROOM SO DOOR DOES NOT TRIP ON ITS OWN DURING CLOSE. NEXT ADJUST "TRIP THRESH" (R16) {STEP 8}
8. TURN R16 "TRIP THRESH" POT FULL CCW. ONCE DOOR IS TRIPPED, STALL DOOR AND APPLY PRESSURE GAUGE SLOWLY. ADJUST THE R16 "TRIP THRESH" UNTIL THE FORCE GAUGE READS THE MAXIMUM DESIRED FORCE DURING A STALL CONDITION. SINCE DOOR MECHANISMS VARY IN LEVERAGE OVER THE TRAVEL OF THE DOOR, CHECK THE FORCE AT SEVERAL DIFFERENT POSITIONS IN THE CYCLE.

NOTE: IF DOOR DOES NOT MOVE IN THE CLOSE DIR, TURN TRIP THRESH OR LOW SPEED CLSE CW.
9. IF EQUIPPED WITH NUDGING, DURING CLOSING CALL FOR A NUDGE INPUT AND SET THE NUDGE SPD POT FOR THE DESIRED DOOR SPEED. THIS CAN BE DONE USING THE ON-BOARD PUSHBUTTONS. IT IS NECESSARY TO PRESS NUDGE AND CLOSE SIMULTANEOUSLY.
10. SET THE CAR FOR NORMAL OPERATION AND VERIFY OPEN AND CLOSE DOOR PERFORMANCE AT ALL FLOORS. CHECK TO MAKE SURE TORQUE LIMIT LED DOES NOT FLICKER DURING

CLOSING (A SHORT BLINK DURING INITIAL OPENING IS OK) AND THAT THE DOOR OPERATION IS SMOOTH AND DOES NOT BUMP EXCESSIVELY AT THE START OR END OF TRAVEL. VERIFY THAT THE STALL FORCE IS WITHIN SPECIFICATIONS ON SEVERAL FLOORS.

IPC D3000 Control Board



# ADJUSTING DOOR DWELL TIMES

---

You can specify how long the controller keeps the car doors open when answering a call. Navigate to the **MAIN MENU | SETUP | DOOR SETUP** menu. Use the following parameters to set the desired dwell times:

## **DOOR DWELL HC**

This parameter specifies how long the car will keep the doors open after answering a hall call. It may be desirable to keep the doors open longer when answering a hall call since the person waiting may not be at the elevator door when it arrives at the floor.

## **DOOR DWELL CC**

This parameter specifies how long the car will keep the doors open after answering a car call.

## **DOOR DWELL REOPEN**

This parameter specifies how long the car will keep the doors open after reopening them in response to a photo-eye, safety edge, or Door Open button being pressed. You may wish to make this timer relatively short.

## **NO DEMAND DOOR OPEN**

This option tells the controller to keep the door open until a call demand is entered into the system. This option is normally used when an automatic car door is opposite a swing style hall door.

## **DOOR TIMEOUT OPEN/CLOSE/NUDGE**

These three timers specify the maximum allowed time for the specified door operation. For example, when the car arrives at a floor, the controller will issue a door open command. If the controller does not see the Door Open Limit reached within the specified Door Timeout Open period, it will attempt to cycle the doors closed and open again. The close and nudge timeouts work in a similar way for those door operations.

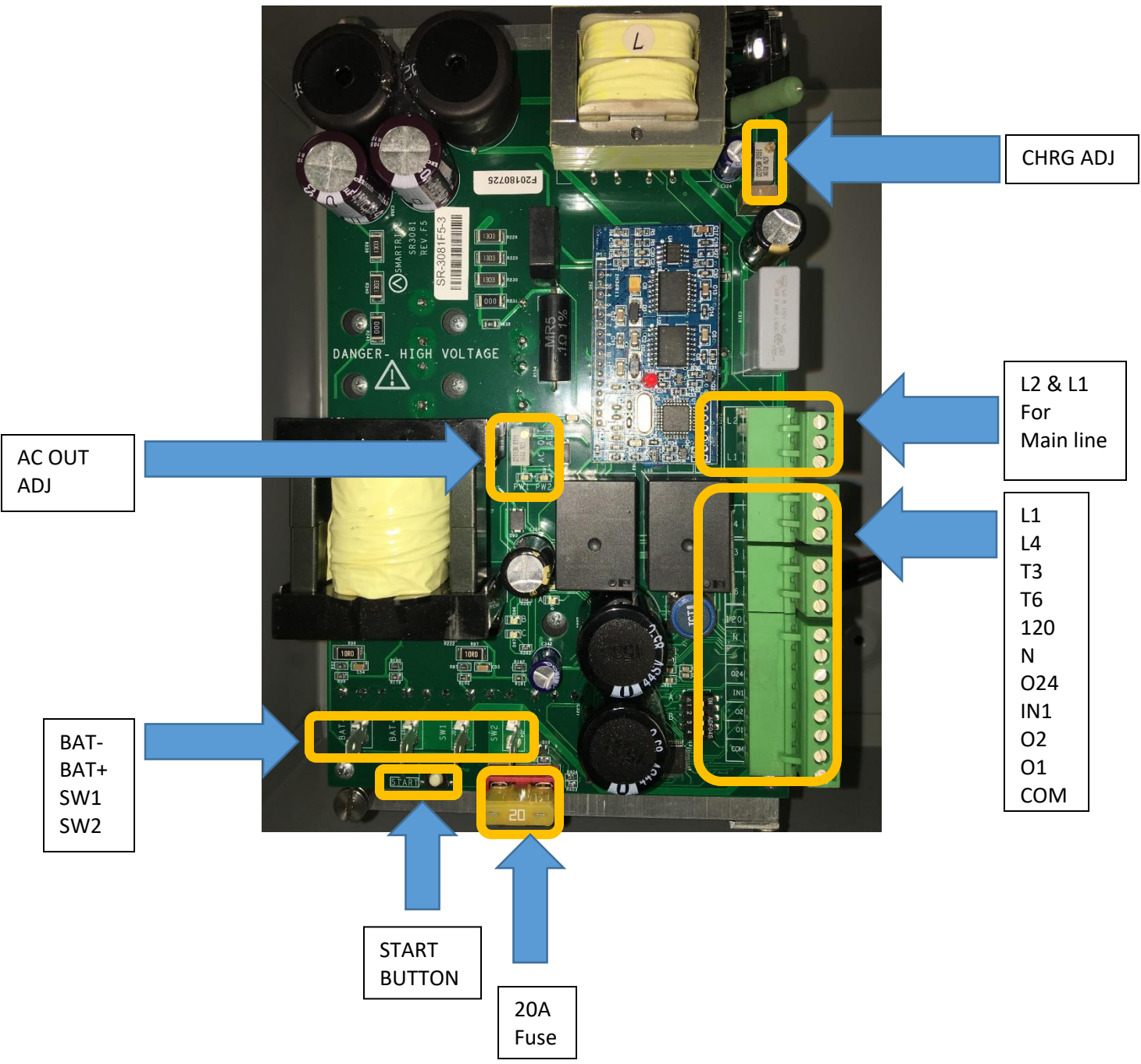
## **DCB CANCELS DWELL**

This parameter allows the Door Close button to cancel the current door dwell and close the doors. If this parameter is set to “no” then the Door Close button has no effect during normal operation.

# BATTERY LOWERING DEVICE



# Smart Battery Lowering Overview





## DESCRIPTION:

The Smart Battery Lowering is intended to replace R&R's RB240 device. It eliminates the need to have a step-down transformer when the main line is above 240VAC. The RB240 is capable of receiving 208VAC or 240VAC, but the Smart Battery Lowering can receive 208VAC, 240VAC, and 480VAC. Like the RB240's batteries, the Smart Battery Lowering's batteries will need to be charged for at least 24 hours.

## **\*WARNING\***

**DO NOT TOUCH THE BOARD WHILE BATTERY LOWERING IS OPERATION DUE TO HIGH VOLTAGE. ONCE UNIT HAS SHUTDOWN, WAIT 2 MINUTES FOR CAPACITORS TO DISCHARGE.**

## TERMINALS:

BAT-: Battery connection (Negative-Black wire)

BAT+: Battery connection (Positive-Red wire)

SW1, SW2: Battery disconnect switch (Black wires)

L1, L2: L1 and L2 from main line. Used to detect main line power loss

L1, T4, T3, T6: External connections based on incoming main line. Refer to [Main line wiring](#)

120, N: 120VAC used to charge the batteries

O24, IN1: For main line aux switch

O2: On battery lowering input to controller

O1: Battery lowering fault input to controller

COM: 24VDC from controller

## LEDS:

FLT: Indicates fault (Battery low)

PW1: Battery voltage is 24VDC

PW2: Internal 15VDC switching voltage is available and device is ready to output AC voltage.

A: Not used

B: Blinking indicates battery is charging

C: Indicates test with use of dip 3 turned ON

## DIP SWITCHES:

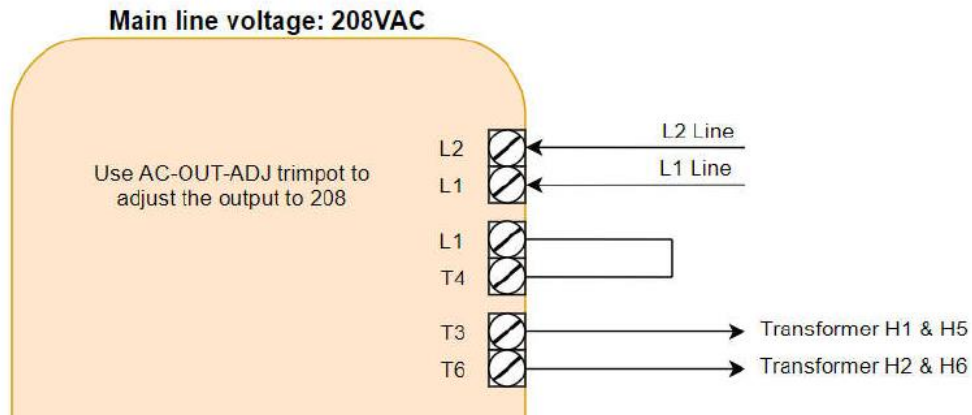
Note: (By default, all 4 are OFF)

- 1: Manual battery output (5 seconds)
- 2: Not used
- 3: Manual Battery test (LED C indicates test)
- 4: Not used

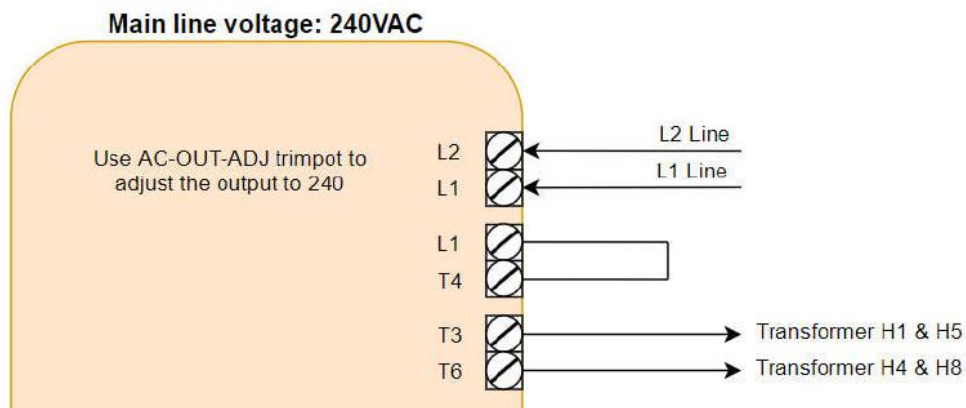
## PUSH BUTTON:

Start: Resets the board

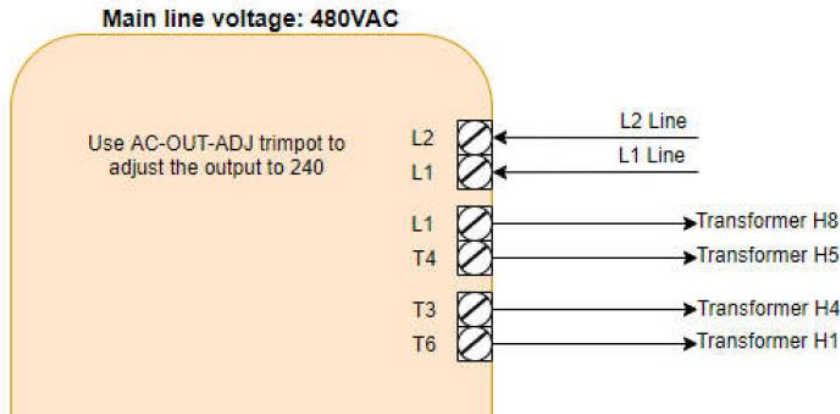
## MAIN LINE WIRING:



## Smart Battery Lowering wiring for main line 208VAC



## Smart Battery Lowering wiring for main line 240VAC

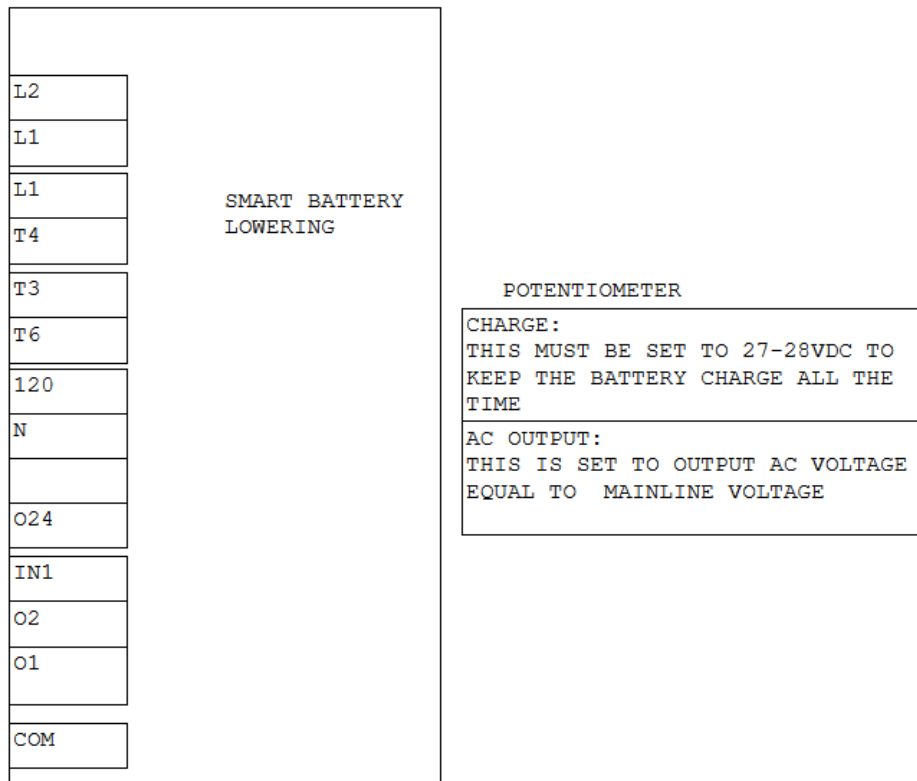


### Smart Battery Lowering wiring for main line 480VAC

#### TRIMPOTS ADJUSTMENT:

- Adjust trimpot “AC OUT ADJ” and measure the voltage coming out of T3 & T6. Measured voltage will need to be main line voltage (i.e. 208VAC, 240VAC, 480VAC).
- Adjust trimpot “CHRG ADJ” and measure the voltage coming out of BAT- & BAT+. Measured voltage will need to be ~27VDC. This is the voltage reading of both 12V batteries together.

#### SMARTRISE SCHEMATIC:



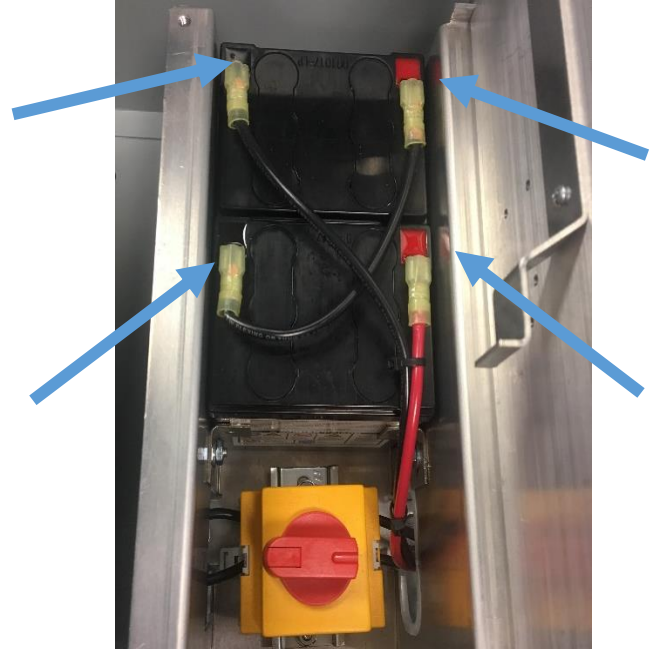
## BATTERY REPLACEMENT:

Battery lifetime = 2 years

1. Remove screws from top left and bottom left corners to access batteries. As shown in the picture below.



**STEP: 1**



**STEP: 2 & 3**

2. Pull the left side of plate and open it showing the 2 batteries.
3. Pull out the old batteries (Note: Pull out the black and red connectors from each battery as shown in the picture above) and replace them with the new batteries.

# REYNOLDS & REYNOLDS BATTERY LOWERING DEVICE – “BLD”

The Reynolds & Reynolds RB2-120 (120vac) and the RB2-240 (240vac) is the battery lowering device Smartrise uses for both their Hydraulic and Traction controllers.

When the controller cabinet arrives, the BLD will have 3 jumpers installed to operate the controller without the BLD being activated.

1. The jumpers between PWR3 & PWR4 and PWR5 & PWR6 are in place to bypass the power at the BLD. When these jumpers are removed and the BLD wiring is properly connected the batteries will start to charge.
2. The jumper between T-CTRL6 & T-CTRL8 is to bypass the Battery Lowering input on the controller. It will need to be removed for the controller to go into Battery Lowering operation.

**CAUTION – You must remove the bypass jumpers between the input and output lines (PWR3-PWR4 & PWR5-PWR6) BEFORE attaching the wires and turning on the BLD. Otherwise, damage could occur to the input/output terminals.**

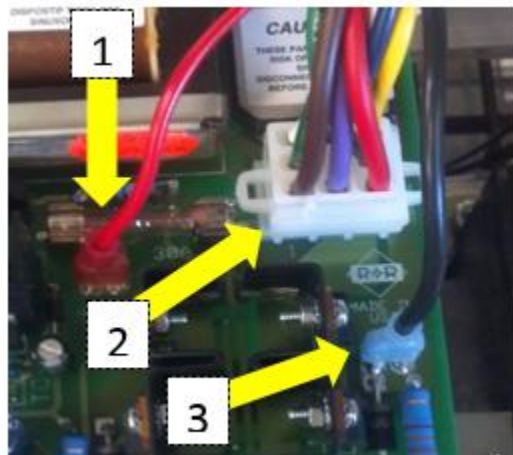
## Installation

When the controller arrives the BLD will not have its control wires connected. This is to prevent the batteries from discharging fully during shipping. The technician must plug these wires in before the BLD is fully functional.

**\*\* (SEE CAUTION NOTE ABOVE) \*\***

The three items that need to be plugged in are:

1. The RED wire to the +B terminal
2. The 9-pin wire harness to the molex plug (MTC) on the control board
3. The BLACK wire to the  $\perp$  terminal



## Testing

To test the BLD perform the following steps:

1. Make sure the BLD is properly connected, all bypass jumpers removed and the batteries have been fully charged (min 24hours).
2. Install a jumper between ML1 & ML2 (see prints for location). This will activate the BLD input.
3. Verify that the Battery Lowering input is active.
4. Turn off main disconnect.
5. Verify that the output voltages match job specifications.
6. The car should lower to the bottom floor and open the doors. The doors will open and then close. The DOB inside the car will function but the hall call button should not.

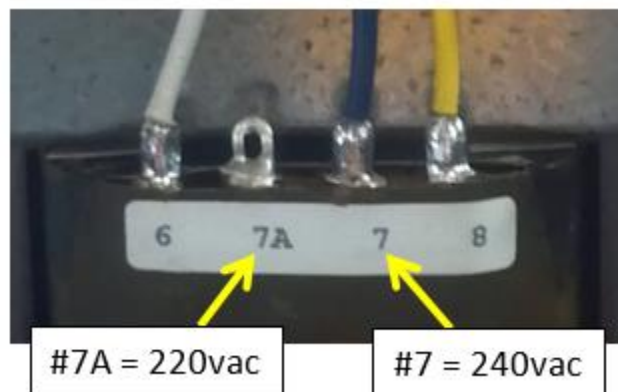
## Troubleshooting

If the input voltages on the BLD are incorrect, follow the section “CHANGING BLD VOLTAGES”.

If the MOVFR door operator doesn't open, follow the section “MOVFR DOOR OPERATOR VOLTAGE ISSUES”.

## Changing BLD Output Voltages

The RB2-240 can operate at voltages from 200vac to 240vac. The tap on the main transformer is factory set for 240vac (#7). The output voltage will be 240vac or greater. If the voltage required is less than 240vac then the blue wire from terminal #7 needs to be moved to the 208vac terminal (7A). This will allow the output voltages to range from 208vac to 220vac.



## BLD / MOVFR DOOR OPERATOR VOLTAGE ISSUES

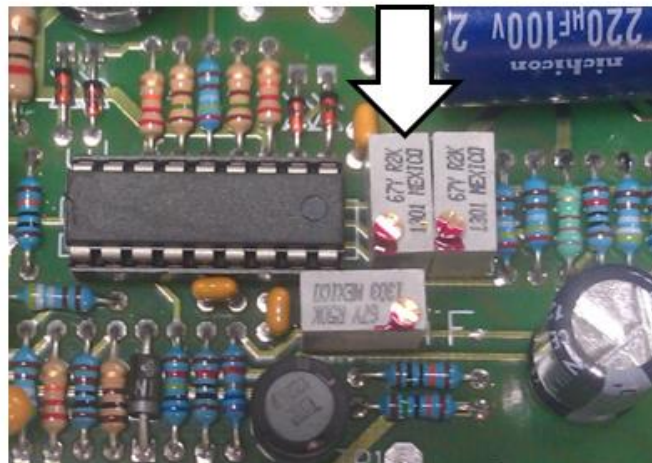
Occasionally a GAL MOVFR door operator will not operate because the output voltage from the BLD going into the secondary transformer is too high. This causes the output voltage to exceed the door operator voltage range and the door operator to fault out. In this case, trimpot "TR" will need to be adjusted to lower the voltage to the secondary transformer which in turn lowers the output voltage to the door operator.

The following procedure will allow you to compensate for the voltage differences in case the voltage cannot be lowered enough using the TR potentiometer.

1. Determine the voltage output requirement for your job and connect the tap accordingly. To adjust, see "**CHANGING BLD OUTPUT VOLTAGES**":
  - a. Tap 7 – 240vac
  - b. Tap 7A – 208vac-220vac

**Note:** When blue wire is on #7 you cannot lower the voltage down below 240vac. You must move the blue wire to terminal #7A and adjust the voltage up from 208vac to 220vac (See **CHANGING BLD OUTPUT VOLTAGES** in **TROUBLESHOOTING** section).

2. Turn off main disconnect and start battery lowering.
3. Measure the output of the BLD from Terminal T-PWR Line 3 or 6 to neutral (N).
4. Adjust the output voltage to the proper range the door operator can run at by adjusting trimpot "TR" (See picture below).





# LEARNING THE HOISTWAY



## Overview

This part of the manual explains how to learn the hoistway and adjust the car. Learning the hoistway is the operation where the controller runs the car from the bottom to the top of the hoistway, recording the location of switches and door zone magnets it sees along the way. Once the hoistway is learned, the controller can run on automatic operation and adjustments to the ride and performance can be made.

## Pre-Check

- A. Does the car move? If not check the Safety String and for correct Door Limit and Hall Lock signals.
- B. Do the DZ magnets register on the selector when passed over?
- C. Is leveling speed < 20 FPM in both directions?
- D. On the machine room SRU: does 509/510 go out when at top floor DZ and 511/512 go out when at the bottom floor DZ?
- E. On the LCD screen: when the car moves up is FPM positive and when moving down is FPM negative?

## Procedure

On the Machine Room SRU board put the controller in Learn mode by flipping DIP Switch #2 (on Dip A) to the right (ON) position. Inspection takes priority over Learn so be sure all the Inspection/Hoistway Access switches in the machine room, cartop, and in the car are in the Normal (automatic) position.

The LCD should now show “Learn” on the Home Screen. This indicates the controller is ready to learn the hoistway. If it still shows “Inspection” then you need to check to see which inspection input(S) are not powered and jump them to 24vdc.

- A. “Inspection (MR)” machine room inspection.
- B. “Inspection (CT)” Cartop Inspection inputs.
- C. “Inspection (HA)” Hoistway Access inputs.
- D. “Inspection (IC)” In-Car inspection inputs.

There are three main steps involved in learning the hoistway. They are all performed from the **MAIN MENU | SETUP | LEARN MODE COMMANDS** menu of the machine room SRU (this option is only available on the Machine Room SRU).

1. Go to **MAIN MENU | SETUP | MISC | BYPASS TERM LIMITS** and set to “YES”.
2. Move the car in Inspection Mode in between the bottom landing and 2nd landing.
3. Are the DET inputs 511/512 on the Machine Room SRU lit?
  - a. If not, go to cartop and check the following:
    - i. Move car next to the DET magnets and check orientation (N/S).
    - ii. Move car over magnet to verify that IP8300 selector is flagging **BZ**.
4. Go to **MAIN MENU | SETUP | MISC | BYPASS TERM LIMITS** and set to “NO”. Press the Enter button.
5. On Dip A – Turn DIP switch #2 to the **ON** position.
6. Set the controller Inspection switch to Normal.
7. Go to **MAIN MENU | SETUP | LEARN MODE COMMANDS | HOMING RUN** – set to “YES”. Press the Enter button.
8. The car will run down until the DET inputs 511/512 go off. If the car is at the bottom landing it will move up until the DET inputs 511/512 come on.
9. Press the left arrow key and select **MOVE TO BOTTOM** and set it to “YES”. Press the Enter button.
10. The car will run down to the top of the door zone – DZ will be in the upper right of the screen.
11. Press the left arrow key and select **LEARN MAGNETS** and set it to “YES”. Press the Enter button.
12. The car will begin running up at leveling speed until it reaches the top door zone magnet.
13. When finished turn DIP switch #2 (DIP A) to the **OFF** position

## Troubleshooting

### 1. HOMING RUN

If the car runs down into the pit or runs up beyond the top floor, it means that the DET signal is not being seen by the controller. Check to make sure you don't have the DET terminals jumped to M24.

### 2. MOVE TO BOTTOM

If the car goes down into the pit it most likely means that the controller is not seeing the bottom door zone magnet or the DZ magnet is too close to the DET magnet. Check that the selector is installed correctly, connected with a standard CAT5 cable and that the door zone magnet is properly

placed with the correct side facing selector. Be sure your leveling speed is around 10 fpm.

### 3. LEARN MAGNETS

At the end of the Learn procedure there may be faults that appear on the screen that are not actually faults but flags that come on during the procedure.

After turning Dip Switch #2 (DIP A) to off you may get the following faults/alarms appear on the LCD screen. **This does not mean the Learn was unsuccessful.**

#### **A60: Position Error**

#### **F205: Need to Learn**

Press the Left (ESC) arrow button. Wait a few moments and verify that these faults are not latched by viewing the RED fault light at the top of the SRU. If the light is not on or goes away then these faults are not “Active” (current) faults and can be ignored.

### 4. “F127:TERM LIMITS” FAULT

Go to **MAIN MENU | SETUP | MISC | BYPASS TERM LIMITS** and set it to “NO”.

### 5. “F91: LEARN ERROR” FAULT

The controller did not see the correct number of door zone magnets. Go to **MAIN MENU | DEBUG | ADJUST PARAMETERS** and look at parameter 00-000. The number after the “x” indicates the number of floors this car has. (x05 = 5 floors). Adjust as necessary and re-learn.

(Example: 00-000 x05 = five floors).

### 6. ETS SWITCH IS OVERLAPPING A DOOR ZONE.

In this case, repeat the learn process and watch the “DZ” indicator on the Home Screen. See that the indicator comes on as the car passes each floor and goes off as it leaves. Watch the feet and inches count and make sure that DZ only comes on at the position of a floor. Also, be sure that you are not missing a door zone magnet at any floor. Finally, be sure that UET and DET are flagging on and off correctly.

### 7. CAR NOT MOVING – DOOR ISSUE

Using the “Car Door” and “Hall Door” data screens verify that the doors are closed and are getting proper signals.

**Doors Closed = GSW / DCL / DPM**

**Doors Open = DOL**

# ADJUSTING CAR SPEEDS

# CAR SPEED PROFILES OVERVIEW

---

Tractions - The Smartrise Controller has individual “Speed Profiles” programmed to operate the car at different speeds based on demand.

Each Speed Profile has the following:

## **Speed**

The speed the car is expected to achieve (and sustain for 1 second or more) when that profile is selected for a run.

## **Slowdown Distance**

The distance from the target floor that the controller will command a speed reduction to leveling speed.

**S# All** – Changes all settings to same value

**S# Up Normal** – Changes the slowdown going UP into a floor for ALL floors (including terminal landings)

**S# Down Normal** – Changes the slowdown going DOWN into a floor for ALL floors (including terminal landings)

**S# Up NTS** – Changes the slowdown going UP into the TOP terminal landing ONLY

**S# Down NTS** – Changes the slowdown going DOWN into the Bottom terminal landing ONLY

## **Minimum Run Distance**

The minimum distance a call must have in order for this speed profile to be selected for a run.

This setting is the one that determines which speed profile is used based on the distance the car is traveling (one floor, two floors, etc.).

Hydros only have one Fast and Slow speed so the controller only uses one Speed Profile (S1) which is equal to the Contract Speed. The slow speed is normally equal to the leveling speed.

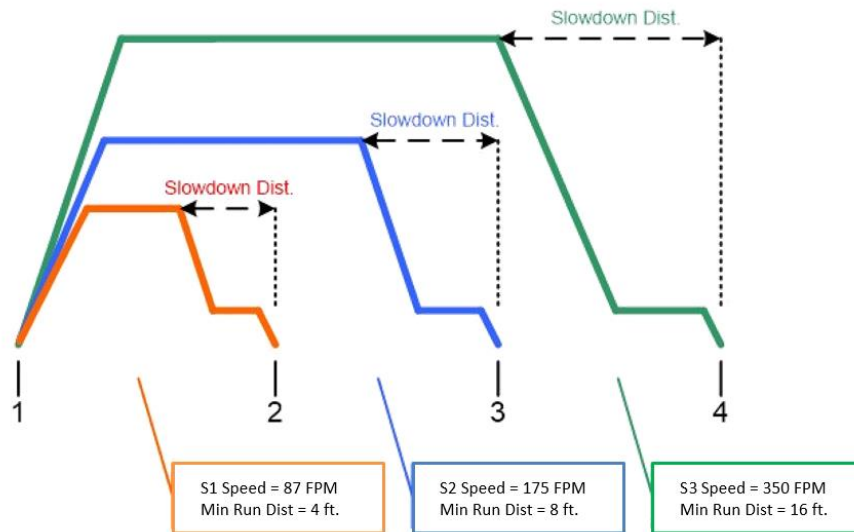
The operation of each speed profile must be defined so the speeds conform to this logic:  $S8 > S7 > S6 > S5 > S4 > S3 > S2 > S1$ . A setting of zero at any “S” speed profile disables that speed setting.

**Example:** The contract speed of a car is 350FPM. The following parameters could be defaulted as:

Contract	=	350 FPM
Inspection	=	50 FPM
Leveling	=	10 FPM
S1 (S1 Speed)	=	87 FPM (1 – Floor Run)
S2 (S2 Speed)	=	175 FPM (2 – Floor Run)
S3 (S3 Speed)	=	350 FPM (3 or more – Floor Run)
S4 thru S8	=	0 FPM (Disabled)

In this example, the controller will command any one of the 3 programmed target speeds based on the MINIMUM RUN DISTANCE.

## Speed Profiles



Each Speed Profile contains a Speed, Slowdown Distances, and Minimum Run Distance. Up to 8 Speed Profiles can be used.

## Setting the Minimum Run Distance for Car Speeds

Adjust the MINIMUM RUN DISTANCES for every Speed Profile to optimize the speed the car runs between floors. This is done by going to **MAIN MENU | SET UP | SPEEDS & SLOWDOWNS | S1, S2, etc. | MIN RUN DISTANCE**.

**NOTE: Do not command too much speed for too short of a rise. This will cause the car to over shoot the landing and fault the drive.**

Example: Using the Speed Profile example below the slowdowns and Min Run Distance can be programmed as illustrated in the following table:

## Default Speed Profile (350)

Speed Profile	Speed	Slowdown	Min Run Dist
S1	87	2'	4'
S2	175	4'	8'
S3	350	8'	16'
...	...	...	...
S8	0	...	...

Profile selections based on 10' floor heights:

S2 = 1 floor run

S3 = 2 or more floor runs

With a floor height of 10':

- ❖ The Min Run Distance determines what Speed Profile is used based on the distance of travel requested.
- ❖ If the distance of travel falls between two Speed Profiles then the lower Speed Profile is used.
- ❖ Since a 1-Floor run is 10', the S2 Speed Profile is used because the Min Run Distance requested falls between the S2 and S3 Speed Profiles.
- ❖ A 2 or more Floor run will use the S3 Speed Profile since 2 floors (20') is greater than the Min Run Distance for S3 (16').

## Adjusting Slowdowns

**Note: If the Controller is power cycled or initialized in the middle of the Hoistway it will NOT command high speed until a terminal landing run has been achieved.**

The controller uses different speed profiles determined by the length of run the car is going to make. Before you adjust the slowdowns, look at the commanding car speed on the lower left hand corner of the LCD main screen.

1. To adjust the slowdown distance, make sure you're adjusting the slowdown distance in the profile you're running the car.
  - a. For instance, using the speed profiles from the previous page, if you're running the car and it's commanding 175FPM then you'll adjust the S2 Slowdown distances. If it's running 350 FPM then you'll adjust the S3 Slowdown distances.
2. Start by adjusting the slowdown distance in the Down direction. Move the car to the top of the Hoistway.
3. On the Machine Room SRU, go to | **MAIN MENU** | **DEBUG** | **ENTER CAR CALLS** to enter a car call for a One Floor run DOWN and observe performance.
4. Note: The car may level for an excessive period of time using the factory defaults. As the Car is leveling observe the performance and reduce or expand the slowdown distance to meet a sustained 4-6 inches of Leveling Speed (or 3-5 seconds) prior to the car reaching floor level and stopping.
5. Adjust all of the Slowdowns Distances in this profile by going to | **MAIN MENU** | **SETUP** | **SPEEDS AND SLOWDOWNS** | **S#** | **S# SLOWDOWNS** | **S# ALL**.
6. If more or less slowdown is desired, simply increase or decrease the distance value in "S1 All" by increasing or decreasing the count value.
7. Now move the car to the bottom of the Hoistway.
8. Enter a car call for a One Floor Run in the up direction to verify that the slowdown previously adjusted is good.
9. Once the One Floor Profile is adjusted, repeat the same procedure for all the higher Speed Profiles you may have.
10. When testing the leveling distance, make sure that the car call you entered is for the correct speed profile.



# ADJUSTING FLOOR LEVELS

## ADJUSTMENT TOO HIGH/TOO LOW METHOD

---

**\*\* CAN ONLY BE DONE FROM THE CT or COP SRU BOARDS \*\***

**NOTE: BE SURE RELEVELING IS TURNED OFF BEFORE ATTEMPTING TO ADJUST THE FLOOR LEVELS.**

Navigate to **MAIN MENU | SETUP | FLOOR LEVELS | RELEVELING** and set it to “**NO**”. Make sure to turn it back on after all floor levels have been set.

### **Bottom Floor**

1. Send the car on a call down to the bottom floor.
2. When the car stops, see if it is level with the landing floor.
3. If the car is level you are finished adjusting this floor.
4. If the car is not level, navigate to the **MAIN MENU | SETUP | FLOOR LEVELS | TOO HIGH/TOO LOW** screen.
5. Use the up and down arrow keys to specify how high or low the car is relative to the landing. Save the value. Be sure the car does not leave the bottom floor until the value has finished saving or that value may get applied to the next floor the car stops at.
6. Send the car to an upper floor then back down to the bottom floor.
7. If the car stops level with the floor you are now finished adjusting the bottom floor. If not, repeat steps 1-6.

### **Intermediate Floors**

1. Start with the car below the target floor (the floor you wish to adjust).
2. Send the car on a call up to the target floor.
3. When the car stops, see if it is level with the landing floor.
4. If the car is level go to the TOP FLOOR procedure.
5. If the car is not level, navigate to the **MAIN MENU | SETUP | FLOOR LEVELS | TOO HIGH/TOO LOW** screen.
6. Use the up and down arrow keys to specify how high or low the car is relative to the landing. Save the value. Be sure the car does not leave the target floor until the value has finished saving or that value may get applied to the next floor the car stops at.
7. Send the car down to a lower floor then back up to the target floor. The car should now stop level with the floor. If not, repeat steps 5-6.

8. Send the car to a floor above the target floor.
9. Enter a call to the target floor so that the car comes down into the floor.
10. If the car stops level with the floor you are now finished adjusting this floor.
11. If the car is not level, perform steps 5-6 above.
12. Repeat these steps for all remaining intermediate floors.

## Top Floor

1. Send the car on a call up to the top floor.
2. When the car stops, see if it is level with the landing floor.
3. If the car is level you are finished adjusting this floor.
4. If the car is not level, navigate to the **MAIN MENU | SETUP | FLOOR LEVELS | TOO HIGH/TOO LOW** screen.
5. Use the up and down arrow keys to specify how high or low the car is relative to the landing. Save the value. Be sure the car does not leave the top floor until the value has finished saving or that value may get applied to the next floor the car stops at.
6. Run the car down to a lower floor and then back up to the terminal landing. Repeat steps 4-5 above until car is level when going into landing.
7. You are now finished adjusting the top floor.

**NOTE: BE SURE RELEVELING IS TURNED ON WHEN FINISHED ADJUSTING THE FLOOR LEVELS.**

Navigate to **MAIN MENU | SETUP | FLOOR LEVELS | RELEVELING** and set it to "YES".

## ADJUSTING UP/DOWN STOP POINTS METHOD

---

**NOTE: BE SURE RELEVELING IS TURNED OFF BEFORE ATTEMPTING TO ADJUST THE FLOOR LEVELS.**

Navigate to **MAIN MENU | SETUP | FLOOR LEVELS | RELEVELING** and set it to “NO”. Make sure to turn it back on after all floor levels have been set.

### UP STOP POINTS

1. To modify the car’s height going UP into a floor (B + ##) navigate to **MAIN MENU | SETUP | FLOOR LEVELS | UP STOP POINT** and scroll to the floor number to adjust. Change the step value to raise or lower the car’s floor level with the landing level.
  - a. If the cars floor is too high going up into the landing lower the B + ## value – (1 step = 3/16”). If the car is too low going up into the landing raise the B + ## value.

### DOWN STOP POINTS

1. To modify the car’s height going DOWN onto a landing (T – ##) navigate to **MAIN MENU | SETUP | FLOOR LEVELS | DOWN STOP POINT** and scroll to the floor number to adjust. Change the step value to raise or lower the car’s floor level with the landing level.
  - a. If the cars floor is too high going down into the landing raise the T – ## value – (1 step = 3/16”). If the car is too low going down into the landing lower the T – ## value.

The illustrations on the next two pages show the position of the car in relation to the floor landing. Adjustments will be made depending on direction of travel.

If the car is going UP into a landing then the value to change will be that landing’s UP STOP POINTS (B + #).

If the car is going down into a landing then the value will be that landing’s DOWN STOP POINTS (T - #).

**The value to change is determined by where the car stops at the landing.**

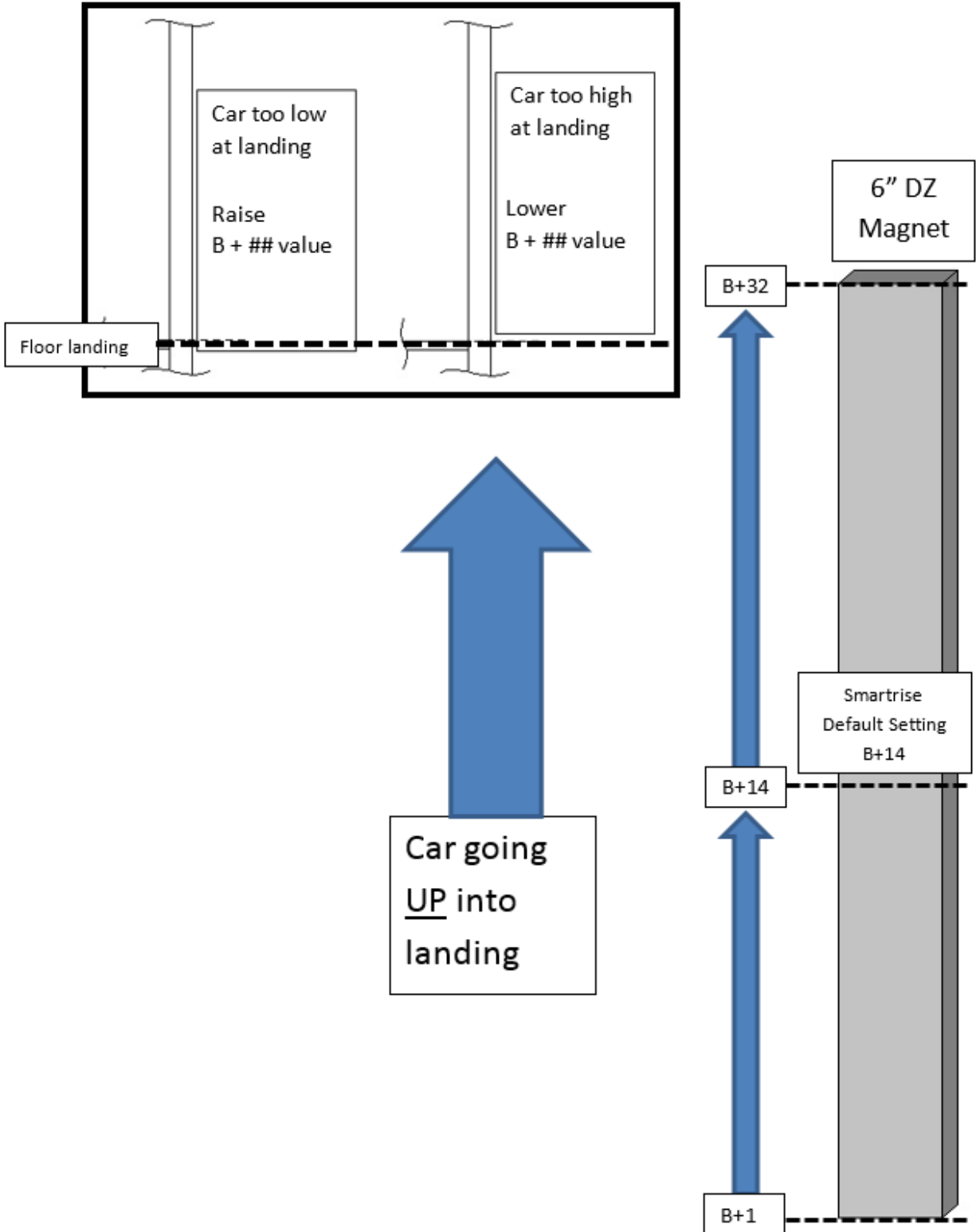
**NOTE: BE SURE RELEVELING IS TURNED ON WHEN FINISHED ADJUSTING THE FLOOR LEVELS.**

Navigate to **MAIN MENU | SETUP | FLOOR LEVELS | RELEVELING** and set it to “YES”.

### UP STOP POINTS - Illustration

If the car stops below the floor level the “B” value will need to increase.

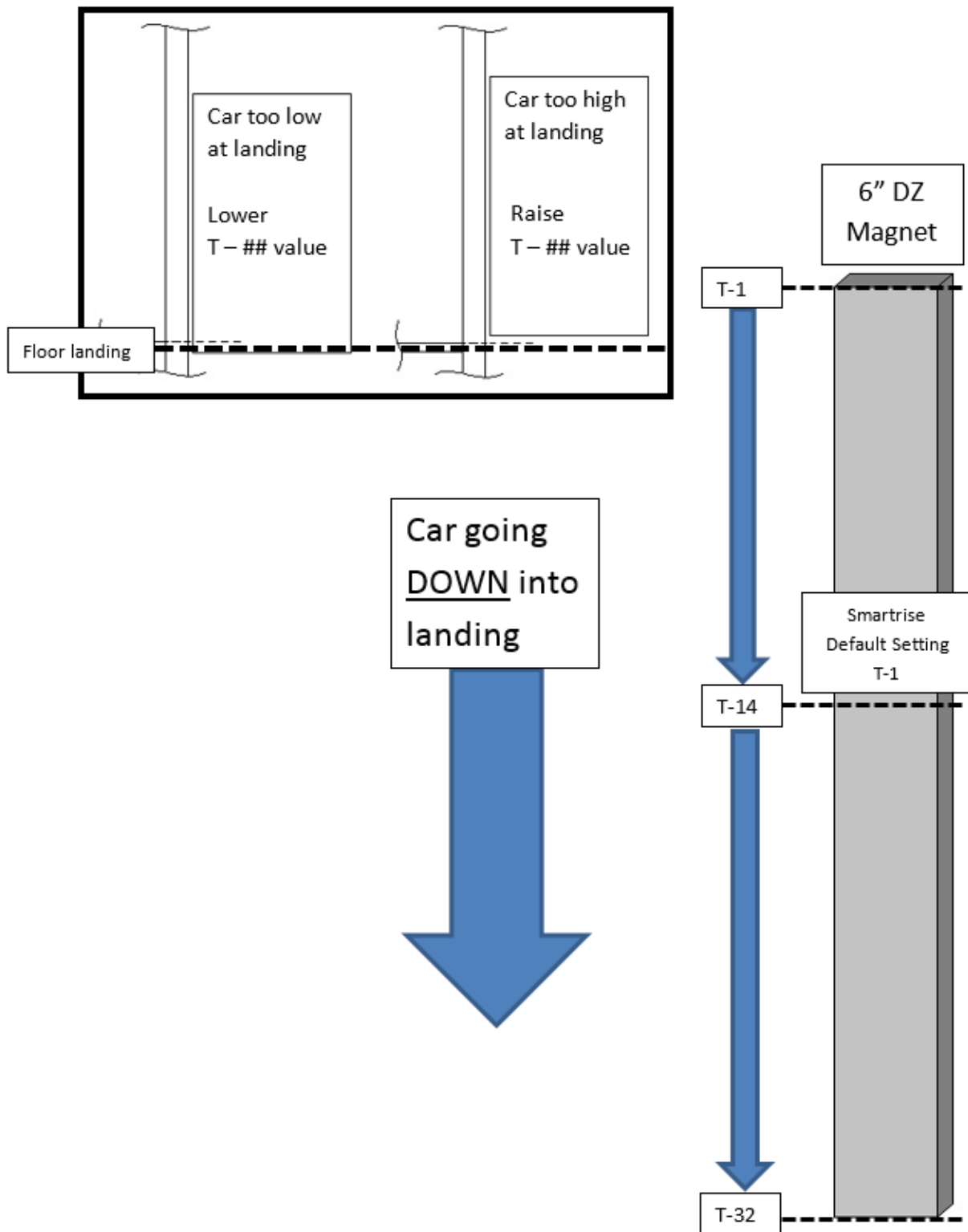
If the car stops above the floor level the “B” value will need to decrease.



## DOWN STOP POINTS - Illustration

If the car stops below the floor level the “T” value will need to decrease.

If the car stops above the floor level the “T” value will need to increase.



# TESTING PROCEDURES FOR HYDRO CONTROLLERS

# EMERGENCY POWER TESTING

---

The Emergency Power option on the Smartrise controller allows 1 or more cars to run on a generator during power outages. The following shows the testing steps for the Emergency Power function:

1. **Step 1 – On Emergency Power** – When this input is activated the fault “F123: Emergency Power” will display on the screen and stop the car immediately until the Generator Up to Speed input is activated.
  - a. Pull the wire from the Emergency Power input (if Normally Closed) or apply 24vDC to the input (if Normally Open).
2. **Step 2 – Generator Up to Speed** – When this input is activated the simplex car will go into normal operation. In a group configuration, each car will move to the recall landing one at a time until all cars are recalled. The car selected by the group switch will then go into Normal Operation while the other cars will stay Out Grp.
  - a. Pull the wire from the Generator Up to Speed input (if Normally Closed) or apply 24vDC to the input (if Normally Open).
  - b. On cars with no Generator Up to Speed switch, this input will be activated with the On Emergency Power input.

**NOTE: The time the cars take to recall in a group configuration can make it appear that the feature is not working. This time is dependent on the**

- a. **Number of cars group,**
- b. **Distance the cars have to travel for recall, and**
- c. **Whether there are cars not in group at time of recall**

**When performing this test there can be a minimum of 5-6 minutes for a 2-car group and much longer with more cars.**

3. **Step 3 – Pre-Transfer** – When this input is active the controller will send the car to the programmed recall landing and open the doors. When the Emergency Power input is deactivated then the car(s) will go into Normal Operation.
  - a. Apply 24vDC to this input to activate this feature.



# NORMAL LIMIT TESTING SETUP

---

## Special Note:

- When testing the limits at the top landings the car should be empty to provide the proper speeds.
- When testing the limits at the bottom landings the car should be fully loaded to overcome the counterweight and provide the proper speeds.

## SPEED PROFILES:

- ❖ During the various testing procedures certain speeds of your car may have to be adjusted. These speeds are located in profiles labeled S1, S2, S3...S8 and are usually different for every job. These profiles are located in **MAIN MENU | SETUP | SPEEDS & SLOWDOWNS**.
- ❖ Use the following chart to record your car speeds.

**MAIN MENU|SETUP|SPEEDS & SLOWDOWNS|S1..S8**

S1 Speed: \_\_\_\_\_ FPM

**MAIN MENU|SETUP|SPEEDS & SLOWDOWNS**

Contract Speed: \_\_\_\_\_ FPM

Inspection Speed: \_\_\_\_\_ FPM

Leveling Speed: \_\_\_\_\_ FPM

## TOP SPEED PROFILE:

Hydro controllers only have one speed profile as there is only high and leveling. The S1 profile will be the one that is adjusted for all high speed testing.

## NORMAL / NTS STOPPING TEST

---

1. Move the car to the top landing.
2. Go to your Top Speed Profile speed (S1) in **MAIN MENU | SETUP | SPEEDS & SLOWDOWNS | S1 | S1 DOWN** \_\_, record the existing values and temporarily set the new values to 00001.
  - a. S1 DOWN Normal – Value: \_\_\_\_\_
  - b. S1 DOWN Normal – Set to 00001. Save this parameter.
3. Enter a call DOWN to a couple of intermediate floors to obtain top speed. Manual car calls will only work from the MR or CT SRU boards.
4. Observe that car achieves top speed, blows through the called floor and logs an “A64:STOP NO DZ” alarm message. This will confirm that the normal means of slowdown is disabled.
5. Send the car to the BOTTOM floor and observe that the car stops at the bottom terminal level. The controller should log a “A72:NTS Overspeed” alarm. This is normal and will confirm the DOWN NTS setting is functioning properly.
6. Restore the previous recorded S# DOWN Normal parameter from (Step 2a).
7. Go to **MAIN MENU | SETUP | SPEEDS & SLOWDOWNS | S1 | S1 SLOWDOWNS | S1 UP** \_\_, record the existing value and temporarily set the new value to 00001.
  - a. S1 UP Normal – Value: \_\_\_\_\_
  - b. S1 UP Normal – Set to 00001. Save this parameter.
8. With the car at the bottom landing, enter a call UP to a couple of intermediate floors to obtain top speed. Manual car calls will only work from the MR or CT SRU boards.
9. Observe that car achieves top speed, blows through the called floor and logs an “A64:STOP NO DZ” alarm message. This will confirm that the normal means of slowdown is disabled.
10. Send the car to the TOP floor and observe that the car stops at the top terminal level. The controller should log a “A72:NTS Overspeed” alarm. This is normal and will confirm the UP NTS setting is functioning properly.
11. When testing is complete for the bottom landing restore the previous recorded S# UP Normal parameter from (Step 7a).

## ETS SLOWDOWN TEST

---

1. This procedure will test the UET (up) and DET (down) stopping devices. The procedure will demonstrate that the car will emergency stop (e-stop) as it passes the ETS locations at contract speed. To demonstrate the operation of the ETS, both the software normal stopping means and the normal terminal stopping device (NTS) will need to be bypassed.
2. On MR controller turn on Dip switch #3 to disable door operation during testing.
3. Prior to starting this procedure take a moment and write down the parameters for S# Slowdowns. This is found by going to the **MAIN MENU | SETUP | SPEEDS & SLOWDOWNS | S1 | S1 SLOWDOWNS**.
4. Write down the following 5-digit number for the parameters below:
  - a. S1 UP Normal – Value: \_\_\_\_\_
  - b. S1 UP NTS – Value: \_\_\_\_\_
  - c. S1 Down Normal – Value: \_\_\_\_\_
  - d. S1 Down NTS – Value: \_\_\_\_\_
5. These values will need to be manually restored after the ETS testing is completed.
6. Command the Car to several floors away from a top terminal and disable the normal stopping means by:
7. Go to **MAIN MENU | SETUP | SPEEDS & SLOWDOWNS | S1 | S1 SLOWDOWNS | UP \_\_**.
  - a. S1 UP Normal – set to 00001. Save this parameter.
  - b. S1 UP NTS – set to 00001. Save this parameter.
8. Initiate a car call from **MAIN MENU | DEBUG | ENTER CAR CALLS** to send the car to the top terminal landing. Manual car calls will only work from the MR or CT SRU boards.
9. Run the car at contract speed to the top terminal landing and verify that the car e-stops (faults). The fault should be “F81:UETS Overspeed”.
10. When testing is complete for the top landing **restore** the previous recorded S1 UP Normal & S1 UP NTS parameter from (Step 4a-b).
11. Go to **MAIN MENU | SETUP | SPEEDS & SLOWDOWNS | S1 | S1 SLOWDOWNS | S1 DOWN \_\_**.
  - a. S1 DOWN Normal – set to 00001. Save this parameter.
  - b. S1 DOWN NTS – set to 00001. Save this parameter.
12. Run the car at contract speed from several floors above the bottom terminal

landing and verify that the car e-stops (faults). The fault should be “F80: DETS Overspeed”.

13. When testing is complete **restore** the previous recorded S1 DOWN Normal & S1 DOWN NTS parameters from (Step 4c-d).

## NORMAL/DIRECTIONAL LIMITS TEST

---

These limits are physical switches electronically calculated by the Smartrise board. Special magnet placement is required for V3 Hydro systems.

1. Run the car on inspection toward the last door zone in either direction and verify that the car stops in the direction of travel when it reaches the last edge of the 2” South Pole magnet.
2. If car did not stop, refer to the “HYDRO DOOR ZONE / TERMINAL LIMIT MAGNET SPECIFICATIONS” section for proper magnet placement.

Completion:

Once the edge of the magnet is reached the car should stop and “A10: At Bottom Term” (for bottom landing) or “A9: At Top Term” (for top landing) should be displayed on the LCD screen.

## RE-LEVELING WITH IN-CAR STOP SWITCH (HYDRAULIC SYSTEM):

---

1. Make sure releveling is set to “YES” in **MAIN MENU | SETUP | FLOOR LEVELS | RELEVELING**
2. Stop car in door zone and turn on In-Car Stop switch.
3. Bleed out valve **SLOWLY** to allow car to drop out of dead zone but **NOT** out of door zone.
4. Car should re-level within a few seconds.

## REDUNDANCY TEST

---

1. If there is a grey jumper installed on a Redundant Input:
  - a. Remove the grey jumper on the terminal you are testing on the SRU board and then test the input. If a grey jumper is connecting two terminals then there should only be one wire going to it. When the state changes on this wired input and the grey jumper is removed then a RND: fault should occur.
2. If there are two wires going to a redundant input:
  - a. Remove one wire and test the input. A RND: fault should occur.

## BATTERY LOWERING TEST

---

To test the BLD perform the following steps:

1. Make sure the BLD is properly connected, all bypass jumpers removed and the batteries have been fully charged (min 24 hours).
2. Install a jumper between ML1 & ML2 (see prints for location). This will activate the BLD input.
3. Verify that the Battery Lowering input is active.
4. Turn off main disconnect.
5. Verify that the output voltages match job specifications.
6. The car should lower to the bottom floor and open the doors. The doors will open and then close. The DOB inside the car will function but the hall call button should not.

# BUFFER TEST (IP8300 LANDING SYSTEM)

---

The physical goal of the buffer test for a hydro system is to run the car at full speed down onto the buffer under power without dropping the down valve. On hydro systems this is only done in the down direction to test the car buffer.

## Hydro systems:

1. Make sure the hoistway and car-top are clear of any personnel and then move the car to the center of the hoistway to ensure the car runs at contract speed.
2. Set all the slowdowns to a value of 00001. This will be done for the fastest speed (usually S1 for Hydros). To do this go to **MAIN MENU | SETUP | SPEEDS & SLOWDOWNS | S1 | S1 SLOWDOWNS | S1 ALL**.
  - a. Step 1: Record original value of S1 All: \_\_\_\_\_
  - b. Step 2: Temporarily change S1 All to 00001 to perform test.
3. On the Din Rail:
  - a. Jump the UET (UET) to DET (DET) terminals together. This will bypass the UET / DET switches.
  - b. Bypass the safety string by jumping terminal SF1 to terminal 120 on the Din Rail. This will allow you to move the car away from the overhead/buffer.
    - i. If you have a CXN board please follow this step: Bypass the safety string by jumping SF2 terminal on the MR din rail to TSF\_OUT on the CXN board.
4. Enter a Car call to the bottom landing. The car should go full speed onto the buffer. Care should be taken when operating the car at full speed without safety features in place.

## Test Completion:

1. Restore all slowdown values recorded in Step 2.
2. Run the car in MR Inspection up above the bottom landing door zone.
3. On the Din Rail:
  - a. Remove the jumper from UET (UET) to DET (DET).
  - b. Remove the jumper from the SF1 terminal to 120.

# BUFFER TEST (CEDES APS LANDING SYSTEM)

---

The physical goal of the buffer test for a hydro system is to run the car at full speed down onto the buffer under power without dropping the down valve. On hydro systems this is only done in the down direction to test the car buffer.

1. Start with car on Normal operation at the **top** floor.
2. Turn on MR DIP switch A3 to disable car door operation.
3. Record the current slowdown distance for all speed profiles that have non-zero speeds.
  - a. Record original value of S1 All: \_\_\_\_\_
  - b. Record original value of S2 All: \_\_\_\_\_
  - c. Record original value of S3 All: \_\_\_\_\_
  - d. Record original value of S4 All: \_\_\_\_\_

*If more than four speed profiles are in use then record them also.*
4. Reduce the slowdown distance for all in-use speed profiles to 00001 count.
5. Record the value of the DETS position parameter which can be found under SETUP | ETS SETUP | DETS POSITION.
  - a. Original value of DETS POSITION: \_\_\_\_\_
6. Set DETS POSITION to 00001.
7. Disable the final limit switches by placing a jumper wire between terminal block SF1 and terminal block PIT on the MR DIN rail.
  - a. If you have a CXN board please follow this step: Bypass the safety string by jumping SF2 terminal on the MR din rail to TSF\_OUT on the CXN board.
8. Place a jumper from QS to M24.
9. On the SRU menu, navigate to SETUP | TIMERS | BRAKE DROP (FAULT) and record its current value.
  - a. Original value of BRAKE DROP (FAULT) : \_\_\_\_\_
10. Change the "Brake Drop (Fault)" parameter to its maximum value of 2.55 seconds.
11. **WARNING:** Ensure that no one is in or on top of the car and in the hoistway before continuing.
12. Use the Debug menu to enter a car call to the **bottom** floor.
13. Car will run at full speed into its buffer.
14. Place car on Inspection after it strikes the buffer.
15. Run car on Inspection out of the pit and up to the bottom floor door zone.
16. Restore the "Brake Drop (Fault)" parameter to its original value.
17. Remove the jumper wire between SF1 and PIT.
18. Restore the DETS POSITION parameter to its original value.

19. Restore the slowdown distance parameters for all in-use speed profiles to their original values.

## STOP RING TEST – LOW SPEED

---

1. Make sure the hoistway and car-top are clear of any personnel and then move the car to the top landing of the hoistway.
2. Go to **MAIN MENU | SETUP | MISC | BYPASS TERM LIMITS** and set to “Yes”.
3. Verify that only the UPL valve goes on when moving in Inspection Speed. If not, go to **MAIN MENU | SETUP | SPEEDS & SLOWDOWNS | INSPECTION SPEED** and lower it enough that only the UPL valve actuates when moving in Inspection Mode.
4. Bypass upper final limit switch (*if installed*).
5. Install a jumper from UET (UET Switch) on the din rail to M24.
  - a. If you are using the APS landing system, set UETS in the ETS SETUP menu to 65530.
6. Run car slowly up onto stop ring using Machine Room Inspection mode.
7. When test is complete, lower car back down to the top landing door zone.
8. Set Bypass Term Limits back to “No”.
9. Set the Inspection Speed back to original value (*if changed*).



## LOW OIL / LOW PRESSURE TEST

---

There are 2 ways of testing for Low Oil or Low Pressure:

1. Low Pressure / Low Oil input programmed
  - a. While the car is running or stopped at a higher floor, pull the wire going to the Low Oil / Low Pressure IO.
  - b. The car should lower to the bottom landing and open the doors.
2. No IO programmed:
  - a. Start with the car on the bottom landing.
  - b. Close the gate valve or remove the coil wire on the UPH terminal.
  - c. Go to **MAIN MENU | SETUP | TIMERS | MAX RUN TIME** and set it to 010 seconds.
  - d. Issue a Car Call to send the car to the top floor.
  - e. In 10 seconds the alarm **A50:MLT** should appear on the LCD screen and the car should lower to the lower landing and the fault F29: Out of Service should appear on the LCD screen.
3. Reset the car by performing a Dip1+Reset on Dipswitch A.

## LEVELING SPEED TEST (V2.35E OR NEWER ONLY)

---

1. Navigate to **MAIN MENU | SETUP | SPEED AND SLOWDOWNS | LEVELING SPEED** and change the speed to a value greater than 150 FPM. Save this value.
2. After saving the new value, you should get a '**F161: Invalid Parameter**' fault in Active Faults. This indicates that the leveling speed is outside its proper operational range.
3. Change the leveling speed back to the original value and save. The fault will automatically reset.

## LEVELING ZONE TEST

---

1. Enter a car call to the bottom landing using **MAIN MENU | DEBUG | ENTER CAR CALLS** and put car in Inspection (MR) Mode.
2. Move the car in Inspection Mode about a foot above the bottom landing.
3. Open the doors using **MAIN MENU | SETUP | DOOR SETUP | MANUAL OPEN & CLOSE**.
  - a. Move asterix under Open and press and hold the Enter button on the SRU controller. The door icon “[ | ]” will change to “[ < | > ]” while opening and then to “< >” when they’re fully open. Release the Enter button at this time and the doors will remain open.
4. Move the Inspection switch back to Normal Mode.
5. Verify that the doors close prior to the car moving. After the doors close the car will move back to the door zone (DZ) in leveling speed.

## PRESSURE TEST (HYDRAULIC SYSTEM):

---

1. Ensure that the **MAIN MENU | SETUP | MISC | BYPASS TERM LIMIT** is still set to “Yes”, and run the car on inspection to the top landing. This procedure ensures the motor’s bypass valve and stop rings operate correctly.
2. In order to test the functionality of the stop ring:
  - a. Command the Car to the top terminal landing and place in Inspection MR.
  - b. Command the car up from the Machine Room and verify the car stops on the ring.
  - c. Disable the car bypass terminal limits by going to **MAIN MENU | SETUP | MISC | BYPASS TERM LIMITS** and set this parameter to “NO” and save it.
  - d. Move the car back down to door zone. If you receive a “Term Limit” error then go back to **MAIN MENU | SETUP | MISC | BYPASS TERM LIMITS** and verify it is saved to “NO”.
3. Place the car in Normal Operation.
4. If experiencing a problem with pressure valve parameter adjustments may be made by utilizing the following submenu:
  - a. **MAIN MENU | SETUP | TIMERS | UP TO SPEED DELAY** : increase or decrease to allow more or less time for the motor to reach speed before the controller operates the up valve (UPL).

## HYDRO RUPTURE SETUP

---

1. If you need to setup and adjust the rupture valve you need to move the car down in a multi-floor run at the highest speed possible.
  - a. If your Contract speed is < 150fpm then you can increase your inspection speed to 150fpm and run it the car on Inspection.
  - b. If your Contract speed is > 150fpm then you have to run the car in Normal mode. You can place car calls using **MAIN MENU | DEBUG | ENTER CAR CALLS**

# TESTING PROCEDURES FOR TRACTION CONTROLLERS

# NORMAL LIMIT TESTING SETUP

---

## Special Note:

- When testing the limits at the top landings the car should be empty to provide the proper speeds.
- When testing the limits at the bottom landings the car should be fully loaded to overcome the counterweight and provide the proper speeds.

## SPEED PROFILES:

- ❖ During the various testing procedures certain speeds of your car may have to be adjusted. These speeds are located in profiles labeled S1, S2, S3...S8 and are usually different for every job. These profiles are located in MAIN MENU | SETUP | SPEEDS & SLOWDOWNS.
- ❖ Use the following chart to record your car speeds.

MAIN MENU|SETUP|SPEEDS & SLOWDOWNS|S1...S8

S1 Speed: \_\_\_\_\_ FPM

S2 Speed: \_\_\_\_\_ FPM

S3 Speed: \_\_\_\_\_ FPM

S4 Speed: \_\_\_\_\_ FPM

S5 Speed: \_\_\_\_\_ FPM

MAIN MENU|SETUP|SPEEDS & SLOWDOWNS

Contract Speed: \_\_\_\_\_ FPM

Inspection Speed: \_\_\_\_\_ FPM

Leveling Speed: \_\_\_\_\_ FPM

Top Speed Profile = S\_\_

## TOP SPEED PROFILE:

The following tests require changing values in the Top Speed Profile (hereafter referred to as "S#") determined from the table above. The Top Speed Profile will be whatever "S" speed that matches the Contract Speed.

Example:

S3 Speed = 350FPM

Contract Speed = 350FPM

S3 is the profile that will be used for S#

## NORMAL / NTS STOPPING TEST

---

1. Move the car to the top landing.
2. Go to your Top Speed Profile speed (S#) in **MAIN MENU | SETUP | SPEEDS & SLOWDOWNS | S# | S# DOWN** \_\_, record the existing values and temporarily set the new values to 00001.
  - a. S# DOWN Normal – Value: \_\_\_\_\_
  - b. S# DOWN Normal – Set to 00001. Save this parameter.
3. Enter a call DOWN to a couple of intermediate floors to obtain top speed. Manual car calls will only work from the MR or CT SRU boards.
4. Observe that car achieves top speed, blows through the called floor and logs an “A64:STOP NO DZ” alarm message. This will confirm that the normal means of slowdown is disabled.
5. Send the car to the BOTTOM floor and observe that the car stops at the bottom terminal level. The controller should log a “A72:NTS Overspeed” alarm. This is normal and will confirm the DOWN NTS setting is functioning properly.
6. Restore the previous recorded S# DOWN Normal parameter from (Step 2a).
7. Go to **MAIN MENU | SETUP | SPEEDS & SLOWDOWNS | S# | S# SLOWDOWNS | S# UP** \_\_, record the existing value and temporarily set the new value to 00001.
  - a. S# UP Normal – Value: \_\_\_\_\_
  - b. S# UP Normal – Set to 00001. Save this parameter.
8. With the car at the bottom landing, enter a call UP to a couple of intermediate floors to obtain top speed. Manual car calls will only work from the MR or CT SRU boards.
9. Observe that car achieves top speed, blows through the called floor and logs an “A64:STOP NO DZ” alarm message. This will confirm that the normal means of slowdown is disabled.
10. Send the car to the TOP floor and observe that the car stops at the top terminal level. The controller should log a “A72:NTS Overspeed” alarm. This is normal and will confirm the UP NTS setting is functioning properly.
11. When testing is complete for the bottom landing restore the previous recorded S# UP Normal parameter from (Step 7a).

# ETS SLOWDOWN TEST

---

1. This procedure will test the UET (up) and DET (down) stopping devices. The procedure will demonstrate that the car will emergency stop (e-stop) as it passes the ETS locations at contract speed. To demonstrate the operation of the ETS, both the software normal stopping means and the normal terminal stopping device (NTS) will need to be bypassed.
2. On MR controller turn on Dip switch #3 to disable door operation during testing.
3. Prior to starting this procedure take a moment and write down the parameters for S# Slowdowns. This is found by going to the **MAIN MENU | SETUP | SPEEDS & SLOWDOWNS | S# | S# SLOWDOWNS**.
4. Write down the following 5-digit number for the parameters below:
  - a. S# UP Normal – Value: \_\_\_\_\_
  - b. S# UP NTS – Value: \_\_\_\_\_
  - c. S# Down Normal – Value: \_\_\_\_\_
  - d. S# Down NTS – Value: \_\_\_\_\_
5. These values will need to be manually restored after the ETS testing is completed.
6. Command the Car to several floors away from a top terminal and disable the normal stopping means by:
7. Go to **MAIN MENU | SETUP | SPEEDS & SLOWDOWNS | S# | S# SLOWDOWNS | UP \_\_**.
  - a. S# UP Normal – set to 00001. Save this parameter.
  - b. S# UP NTS – set to 00001. Save this parameter.
8. Initiate a car call from **MAIN MENU | DEBUG | ENTER CAR CALLS** to send the car to the top terminal landing. Manual car calls will only work from the MR or CT SRU boards.
9. Run the car at contract speed to the top terminal landing and verify that the car e-stops (faults). The fault should be “F81:UETS Overspeed”.
10. When testing is complete for the top landing **restore** the previous recorded S# UP Normal & S# UP NTS parameter from (Step 4a-b).
11. Go to **MAIN MENU | SETUP | SPEEDS & SLOWDOWNS | S# | S# SLOWDOWNS | S# DOWN \_\_**.
  - a. S# DOWN Normal – set to 00001. Save this parameter.
  - b. S# DOWN NTS – set to 00001. Save this parameter.
12. Run the car at contract speed from several floors above the bottom terminal

landing and verify that the car e-stops (faults). The fault should be “*F80: DETS Overspeed*”.

13. When testing is complete **restore** the previous recorded S# DOWN Normal & S# DOWN NTS parameters from (Step 4c-d).

## NORMAL/DIRECTIONAL LIMITS

---

These limits are physical switches electronically calculated by the Smartrise board and activated at the outside edge of the terminal landing DZ magnets.

1. Run the car on inspection toward the last door zone in either direction and verify that the car stops in the direction of travel when it reaches the last edge of the last door zone magnet.
  - a. If the floor level is in the middle of the magnet then the limits are 3 inches below the magnet for the bottom terminal -- 3 inches above for the top magnet. If 3 inches of over-travel is too much, simply move the bottom magnet(s) up more and move the top magnet(s) down more in order to achieve your desired result.
  - b. If magnets are moved in step 1.a then a “Learn” procedure will have to be performed and floor height settings readjusted at these locations.



## REDUNDANCY TEST

---

1. If there is a grey jumper installed on a Redundant Input:
  - a. Remove the grey jumper on the terminal you are testing on the SRU board and then test the input. If a grey jumper is connecting two terminals then there should only be one wire going to it. When the state changes on this wired input and the grey jumper is removed then a RND: fault should occur.
2. If there are two wires going to a redundant input:
  - a. Remove one wire and test the input. A RND: fault should occur.

## MANUAL BRAKE RELEASE TEST

---

See Addendum III – Traction Brake Pick Operation

## BATTERY LOWERING TEST

---

To test the BLD perform the following steps:

1. Make sure the BLD is properly connected, all bypass jumpers removed and the batteries have been fully charged (min 24hours).
2. Install a jumper between ML1 & ML2 (see prints for location). This will activate the BLD input.
3. Verify that the Battery Lowering input is active.
4. Turn off main disconnect.
5. Verify that the output voltages match job specifications.
6. The car should lower to the bottom floor and open the doors. The doors will open and then close. The DOB inside the car will function but the hall call button should not.

# BUFFER TEST/COUNTERWEIGHT TEST (IP8300 LANDING SYSTEM)

---

The physical goal of the buffer test for a traction system is to run the car at full speed into the buffer under power without dropping the brake, thus breaking traction. This is done in the down direction to test the car buffer and the up direction to test the counterweight buffer.

## Setup:

1. Make sure the hoistway and car-top are clear of any personnel and then move the car to the center of the hoistway to ensure the car runs at contract speed.
2. Set all the slowdowns to a value of 00001. This will be done for the fastest speed S# - (usually S3 for tractions, S1 for Hydros). To do this go to **MAIN MENU | SETUP | SPEEDS & SLOWDOWNS | S# | S# SLOWDOWNS | S# ALL**.
  - a. Step 1: Record original value of S# All: \_\_\_\_\_
  - b. Step 2: Temporarily change S# All to 00001 to perform test.
3. On the Din Rail:
  - a. Jump the UET (UET) to DET (DET) terminals together. This will bypass the UET / DET switches.
  - b. Bypass the safety string by jumping terminal SF1 to terminal 120 on the Din Rail. This will allow you to move the car away from the overhead/buffer.
    - i. If you have a CXN board please follow this step: Bypass the safety string by jumping SF2 terminal on the MR din rail to TSF\_OUT on the CXN board.

## Testing:

1. Go to **MAIN MENU | SETUP | TIMERS | BRAKE DROP (FAULT)** and record original value.
  - a. Record original value: \_\_\_\_\_
  - b. Temporarily set it to the maximum of 2.55 seconds.
2. Enter a Car call to the bottom landing. The car should go full speed into the buffer. Care should be taken when operating the car at full speed without safety features in place.
3. Place car in Inspection and move the car up onto door zone magnet.
4. Put car in Normal operation and allow it to level into floor.
5. Perform Step 2 in the UP direction to test the counterweight buffer.
6. Restore the Brake Drop (Fault) value recorded in Step 1.

## Test Completion:

1. Restore all slowdown values recorded in Step 2 of “Hydros and Traction systems” on previous page.
2. On the Din Rail:
  - a. Remove the jumper from UET (UET) to DET (DET).
  - b. Remove the jumper from SF1 to 120.
  - c. If car is lost, perform the **HOMING RUN** and **MOVE TO BOTTOM**.

## BUFFER TEST/COUNTERWEIGHT TEST (CEDES APS LANDING SYSTEM)

---

The physical goal of the buffer test for a hydro system is to run the car at full speed down onto the buffer under power without dropping the down valve. On hydro systems this is only done in the down direction to test the car buffer.

20. Start with car on Normal operation at the **top** floor.

21. Turn on MR DIP switch A3 to disable car door operation.

22. Record the current slowdown distance for all speed profiles that have non-zero speeds.

- a. Record original value of S1 All: \_\_\_\_\_
- b. Record original value of S2 All: \_\_\_\_\_
- c. Record original value of S3 All: \_\_\_\_\_
- d. Record original value of S4 All: \_\_\_\_\_

*If more than four speed profiles are in use then record them also.*

23. Reduce the slowdown distance for all in-use speed profiles to 00001 count.

24. Record the value of the DETS position parameter which can be found under SETUP | ETS SETUP | DETS POSITION.

- a. Original value of DETS POSITION: \_\_\_\_\_

25. Set DETS POSITION to 00001.

26. Disable the final limit switches by placing a jumper wire between terminal block SF1 and terminal block PIT on the MR DIN rail.

- a. If you have a CXN board please follow this step: Bypass the safety string by jumping SF2 terminal on the MR din rail to TSF\_OUT on the CXN board.

27. Place a jumper from QS to M24.

28. On the SRU menu, navigate to SETUP | TIMERS | BRAKE DROP (FAULT) and record its current value.

- a. Original value of BRAKE DROP (FAULT) : \_\_\_\_\_

29. Change the “Brake Drop (Fault)” parameter to its maximum value of 2.55 seconds.
30. **WARNING:** Ensure that no one is in or on top of the car and in the hoistway before continuing.
31. Use the Debug menu to enter a car call to the **bottom** floor.
32. Car will run at full speed into its buffer.
33. Place car on Inspection after it strikes the buffer.
34. Run car on Inspection out of the pit and up to the bottom floor door zone.
35. Record the value of the UETS position parameter which can be found under SETUP | ETS SETUP | UETS POSITION.
  - a. Original value of UETS POSITION: \_\_\_\_\_
36. Set UETS POSITION to 65530.
37. Use the Debug menu to enter a car call to the **top** floor.
38. Car will run at full speed to the top to test the counterweight.
39. Place car on Inspection after it strikes the top.
40. Run car on Inspection out of the top and down to the top floor door zone.
41. Restore the “Brake Drop (Fault)” parameter to its original value.
42. Remove the jumper wire between SF1 and PIT.
43. Restore the DETS/UETS POSITION parameter to its original value.
44. Restore the slowdown distance parameters for all in-use speed profiles to their original values.

## PRESSURE TEST (HYDRAULIC SYSTEM):

1. Ensure that the MAIN MENU | SETUP | MISC | BYPASS TERM LIMIT is still set to “Yes”, and run the car on inspection to the top landing. This procedure ensures the motor’s bypass valve and stop rings operate correctly.
2. In order to test the functionality of the stop ring:
  - a. Command the Car to the top terminal landing and place in Inspection MR.
  - b. Command the car up from the Machine Room and verify the car stops on the ring.
  - c. Disable the car bypass terminal limits by going to MAIN MENU | SETUP | MISC | BYPASS TERM LIMITS and set this parameter to “NO” and save it.
  - d. Move the car back down to door zone. If you receive a “Term Limit” error then go back to MAIN MENU | SETUP | MISC | BYPASS TERM LIMITS and verify it is saved to “NO”.
3. Place the car in Normal Operation.
4. If experiencing a problem with pressure valve parameter adjustments may be made by utilizing the following submenu:
  - a. MAIN MENU | SETUP | TIMERS | UP TO SPEED DELAY : increase or decrease to allow more or less time for the motor to reach speed before the controller operates the up valve (UPL).

## RE-LEVELING WITH IN-CAR STOP SWITCH (HYDRAULIC SYSTEM):

---

1. Stop car in door zone and turn on In-Car Stop switch.
2. Bleed out valve SLOWLY to allow car to drop out of dead zone but NOT out of door zone.
3. Car should re-level within a few seconds.

## STOP RING TEST – LOW SPEED

---

1. Make sure the hoistway and car-top are clear of any personnel and then move the car to the top landing of the hoistway.
2. Go to **MAIN MENU | SETUP | MISC | BYPASS TERM LIMITS** and set to “Yes”.
3. Verify that only the UPL valve goes on when moving in Inspection Speed. If not, go to **MAIN MENU | SETUP | SPEEDS & SLOWDOWNS | INSPECTION SPEED** and lower it enough that only the UPL valve actuates when moving in Inspection Mode.
4. Bypass upper final limit switch (*if installed*).
5. Install a jumper from UET (UET Switch) on the din rail to M24.
  - a. If you are using the APS landing system, set UETS in the ETS SETUP menu to 65530.
6. Run car slowly up onto stop ring using Machine Room Inspection mode.
7. When test is complete, lower car back down to the top landing door zone.
8. Set Bypass Term Limits back to “No”.
9. Set the Inspection Speed back to original value (*if changed*).

# OVERSPEED AND GOVERNOR TEST – MAGNETEK DRIVE

---

There are three tests to perform for the Overspeed and Governor test; Smartrise Overspeed test, Governor Switch test and Governor Mechanical test. The following procedures will test all three items.

## Smartrise Controller Overspeed test:

1. Move the car to the top landing.
2. Go to the Magnetek Drive Menu Parameter. Adjust Drive A1:
  - a. Increase the “Contract Mtr Spd” by 50%:  
Original Value: \_\_\_\_\_ x (1.5) = New Value: \_\_\_\_\_
3. Enter a Car Call in the Down Direction via MAIN MENU | DEBUG | ENTER CAR CALLS.
4. The drive will run the motor at an increased speed causing it to run faster than commanded resulting in an overspeed fault. If more speed is required to achieve an overspeed condition, simply increase this parameter further.

## Governor Electrical Switch test:

1. On the Smartrise controller, increase Contract speed by 150% (MAIN MENU | SETUP | SPEEDS & SLOWDOWNS | CONTRACT SPEED).

Original Value: \_\_\_\_\_ x (1.5) = New Value: \_\_\_\_\_

NOTE: (Smartrise controllers cannot exceed 900FPM)

2. Set the S# speed by 50%. *S# is your highest speed profile on SRU controller.*

Original Value: \_\_\_\_\_ x (1.5) = New Value: \_\_\_\_\_

NOTE: (Smartrise controllers cannot exceed 900FPM)

3. Enter a Car Call in the Down Direction via MAIN MENU | DEBUG | ENTER CAR CALLS.
4. At 125% of rated contract speed the Governor should trip causing the car to E-Stop.
  - a. The Governor contact should open and the Machine Room Board Input should NOT be on.
  - b. A mechanical reset might be needed if the Governor doesn't reset automatically.

## Governor Mechanical test:

1. This test will reuse the settings changed in the previous two tests.
2. Apply a jumper from M24 to the governor input on the Smartrise SRU board.
3. Enter a Car Call in the Down Direction via MAIN MENU | DEBUG | ENTER CAR CALLS.
4. The drive will run the motor at an increased speed causing it to run faster than commanded. At approximately 125%-150% of rated contract speed the Governor should mechanically trip causing the car to E-Stop.

## Resetting and restoring values:

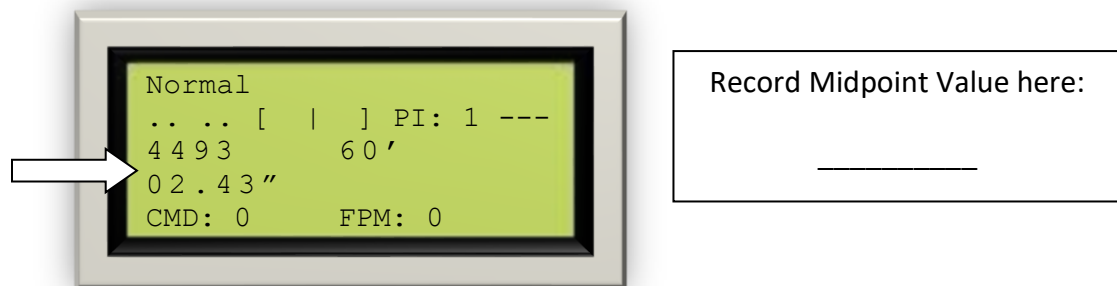
1. Reset the Magnetek parameter Drive A1 - "Contract Mtr Spd" and the SRU Contract speed back to original values.
2. Turn on DIP Switch #1 and press the Reset Button.
3. Turn off DIP switch #1 and the Car should return to Normal Operation.

## EARTHQUAKE COUNTERWEIGHT TEST

---

This test is designed to test the operation of earthquake and counterweight logic

1. Make sure the counterweight mid-point parameter is set. Go to MAIN MENU | SETUP | FIRE/EARTHQUAKE | COUNTERWEIGHT MID PT and input the midpoint distance of the hoistway. The midpoint distance can be determined by moving the car in the hoistway level with the counterweight and recording the step position from the SRU screen, located above the "CMD:" value in the lower left corner.



2. Momentarily jump either of the EQ (+/-) terminals on the Machine Room DIN rail to the Earth Ground terminal on the DIN rail.
3. The Car should stop and correct away from the counterweight to the nearest landing. There it will open the doors, fault out, and go out of service.
4. To reset: Make sure the counterweight input is high (LED is on) and then



press the reset button. This will reset the Earthquake logic.

## LEVELING ZONE TEST

---

6. Enter a car call to the bottom landing using MAIN MENU | DEBUG | ENTER CAR CALLS and put car in Inspection (MR) Mode.
7. Move the car in Inspection Mode about a foot above the bottom landing.
8. Open the doors using MAIN MENU | SETUP | DOOR SETUP | MANUAL OPEN & CLOSE.
  - a. Move asterix under Open and press and hold the Enter button on the SRU controller. The door icon “[ | ]” will change to “[ < | > ]” while opening and then to “< >” when they’re fully open. Release the Enter button at this time and the doors will remain open.
9. Move the Inspection switch back to Normal Mode.
10. The doors will close and the car will move back to the door zone (DZ) in leveling speed.

## UNINTENDED MOVEMENT

---

This test is designed to test the operation of the rope gripper in the event that the car moves unintentionally in a door zone with the Hall AND Car doors open. This test is normally performed in Normal Operation mode. *NOTE: If performing this test in Inspection MR mode, make sure Binary Parameter 00-110.4 is set to “Yes”.*

1. Verify that (DIP A) Dip switch #3 on the machine room SRU controller is not on.
2. Go to MAIN MENU | SETUP | DOOR SETUP | NO DEMAND DO to “YES” and SAVE it.
3. Enter a car call to the bottom landing.
4. The car should remain at the landing with the Hall AND Car doors open so long as another Hall or Car call is not entered.
5. Manually lift the brake by:
  - a. Install a jumper from M24 to A1 on the PICK relay.
  - b. Install a jumper from REF to A2 on the PICK relay.
6. Manually compress/close the M and B contactors. This will apply a picking voltage to the brake and it should lift.
  - a. For PM only: Go to MAIN MENU | DEBUG | ADJUST PARAMETERS and record the value for 13-175, then change it to x00. This will allow the Ebrake to stay picked until an emergency situation occurs.

Original Value: x\_\_\_\_\_

New Value: x00

7. The car should drift up. If not the gearing of the machine may be low such that it may have to be turned via a wrench with the brake lifted.
8. If car still doesn't move try raising the car to the top landing and putting in weights to overcome the counterweight.
9. As soon as the controller detects an out of Door Zone state with the doors open the Controller will drop the Gripper.
10. Release the Brake or M and B Contactors.
11. If the doors did not close automatically, place the Car on Inspection MR and go to MAIN MENU | SETUP | DOOR SETUP | MANUALLY OPEN AND CLOSE and close the doors manually by moving the asterix under the NUDGE option and holding the ENTER key.
12. Remove all jumpers from the PICK relay.
  - a. For PM only: Restore the recorded value from step 6a back into 13-175.
13. Turn on DIP Switch #1 and press the Reset Button. The E-Brake fault may require a power cycle to clear.
14. Turn off DIP Switch #1.
15. On the SRU go to MAIN MENU | SETUP | DOOR SETUP | NO DEMAND DO to "NO" and SAVE it.
16. Set the car back to Normal Operation mode. The car should correct to the floor.

## RACK AND PINION DROP TEST

---

### Setup

1. Move car to top landing
2. Pick the brakes by:
  - a. Install a jumper wire between 120 and SF1 on the Din Rail.
  - b. Install a jumper wire between M24 and A1 of the Pick relay.
  - c. Install a jumper wire between REF and A2 of the Pick relay.

### Testing

1. Manually press in the M and B contactor. This will allow the car to drop.
2. When the car reaches the over speed threshold it will trip the over speed device, and the car should come to a stop.
3. The Smartrise controller should register a governor fault at this time.

### Restore

1. Install a jumper wire between M24 and the Governor input
  - a. Refer to the drawings – Sheet 2 or the supplied IO sheet located in the binder for the location of the Governor input.
2. Put the car into MR Inspection mode and run the car up 8” or so to unlock the over speed device.
3. While still in MR Inspection move the car down until the top of car can be accessed.
4. Reset the over speed device located on top of the car.
5. Remove previously installed jumpers:
  - a. M24 and the governor input
  - b. 120 and SF1 on the Din Rail
  - c. Pick Relay:
    - i. M24 to A1
    - ii. Ref to A2
6. Turn off MR Inspection Mode

# LOSS OF TRACTION TEST (2010 CODE COMPLIANCE ONLY)

---

## Testing Notes:

This procedure is for Traction cars only. This test causes the controller to fault when it commands a speed and receives no car speed feedback, simulating loss of traction.

## Setup

**NOTE: Follow these steps if it is not a CEDES landing system.**

1. Go to **MAIN MENU | DEBUG | BINARY PARAMETERS**
  - a. Enter 00-017.7 and change it to “**NO**”. Save value.
2. Disconnect the **DP1/DP2 or GEA/GEB** wires from the Car (CT) SRU board.
3. Go to **MAIN MENU | DEBUG | ENTER CAR CALLS** and enter a call to another floor.

The car may move slightly prior to faulting out with a **'F71: Speed Dev Err'** fault. When this fault occurs the car will stop and will not run until reset. In order to get the car operational again the technician will have to manually reset the controller. **\*\* Power cycling the controller will not work. \*\***

**NOTE:** Follow these steps if it is a CEDES landing system.

1. Start with the car on Normal Operation (at any floor)
2. Go to Adjust Parameters and enter 13-164. Record original x-value here:  
\_\_\_\_\_
3. Change x-value for parameter 13-164 to x00
4. Place a car call through the Debug Menu to any floor. The controller will fault out with a F71 Speed Deviation, simulating a loss of traction
5. When done, change parameter 13-164 back to its original x-value

You will also have to manually reset the controller by doing a DIP Switch 1 on Dip A Reset.

## Restore

- ❖ Reconnect DP1/DP2 wires or GEA/GEB wires.
- ❖ If no Traction Loss Key switch installed
  1. Turn on Dip1 (on Dip A) on the machine room SRU board and push the Reset button to clear this fault.

2. Turn off Dip Switch 1.

❖ With Traction Loss Key switch

1. Insert the round Traction Loss key into the key switch and turn it on to reset the system. The switch is spring loaded so it will return automatically to the off position. The key can only be removed when in the off position.
2. Remove the key.
3. Power Cycle the controller.

# OTHER ADJUSTMENTS

---

## ACCESS TOP/BOTTOM LIMITS:

1. To set the access distance, simply adjust the parameters ACCESS DIST TOP and ACCESS DIST BOTTOM located under MAIN MENU | SETUP.

## POSITION INDICATOR VIA CE:

1. Floor labels can be programmed at MAIN MENU | SETUP | PI LABELS if a CE micro-com or Emotive fixture is installed.

## RESYNCHING - HYDROS

1. Set real-time clock time/date at MAIN MENU | SETUP | REAL-TIME CLOCK
2. Set releveling to Yes in MAIN MENU | SETUP | FLOOR LEVELS | RELEVELING
3. Set resynch start time at MAIN MENU | SETUP | MISC | RESYNCH START TIME
4. Set resynch duration at MAIN MENU | SETUP | MISC | RESYNCH DURATION

## SIMPLEX PARKING SETUP

1. Go to MAIN MENU | SETUP | GROUP SETUP | PARK DELAY TIME to setup the delay time until the car goes into park mode (000 secs)
2. Parameter 00-083 sets the park floor in MAIN MENU | DEBUG | ADJUST PARAMETERS
  - a. (x00 = bottom floor, x02 = 2<sup>nd</sup> floor, etc.)
  - b. Example: PI for a 4 stop is labeled: G, L, 2, 3
    - i. 00-083 = x00 car will park at G,
    - ii. 00-083 = x01 will park car at L, etc.

## HYDRO RUPTURE SETUP

2. If you need to setup and adjust the rupture valve you need to move the car down in a multi-floor run at the highest speed possible.
  - a. If your Contract speed is < 150fpm then you can increase your inspection speed to 150fpm and run it the car on Inspection.
  - b. If your Contract speed is > 150fpm then you have to run the car in Normal mode. You can place car calls using MAIN MENU | DEBUG | ENTER CAR CALLS

# SMARTRISE MENU DEFINITIONS

---

## ❖ MAIN MENU | STATUS |

### ➤ I/O

#### ▪ INPUT GROUPS

- Displays the real time status of any programmed input.

### ➤ MAGNETS

#### ▪ DZ1 Top/Bottom for all floors

- Displays the precise location, in feet and in counts, of the Top and Bottom on every programmed DZ magnet.

### ➤ SWITCHES

#### ▪ HOISTWAY SWITCHES (UET/DET)

- Displays the precise location, in feet and in counts, of the UET and DET switches.

### ➤ HALL BOARDS

#### ▪ ACCESS BOTTOM

- Displays the communication and button status of the Access Bottom Hall Board.

#### ▪ ACCESS TOP

- Displays the communication and button status of the Access Top Hall Board.

#### ▪ FIRE RECALL

- Displays the communication and button status of the Fire Recall Hall Board.

#### ▪ EMS

- Displays the communication and button status of the EMS Hall Board.

#### ▪ HALL CALL BOARDS (F/R)

- Displays the communication and button status of the Riser Hall Board.

#### ▪ HALL LANTERNS (F/R)

- Displays the communication and button status of the Lantern Hall Board.

## ❖ MAIN MENU | FAULTS |

### ➤ ACTIVE

- Displays current active faults that are preventing the car from running.

### ➤ LOGGED

- Displays the 15 latest faults stored in the board's non-volatile memory with the most recent faults at the bottom.

### ➤ CLEAR LOG

- Clears the fault log history.

## ❖ MAIN MENU | SETUP | SPEEDS & SLOWDOWNS |

### ➤ CONTRACT

- Sets the Contract speed the car should or is actually running at. See actual car speed next to "FPM" to see if this value is correct.

### ➤ INSPECTION SPEED

- Sets the speed the Controller uses for all inspection modes. By code this speed may not exceed 150 FPM.

### ➤ LEVELING SPEED

- Sets the speed the Controller uses while leveling in a Door Zone.

### ➤ RELEVELING SPEED

- Sets the speed the Controller uses while releveling in a Door Zone.

- LIMITED SPEED
  - Sets the speed a user can program to prevent the car from over-speeding.
- S1
  - S1 SPEED
    - Speed set for S1. For tractions this is usually the slowest speed for the car. For Hydro's this is usually the contract speed.
  - S1 SLOWDOWNS
    - S1 ALL
      - ◆ This parameter will set the same level for the Up and Down Normal and NTS slowdowns. Use this if individual slowdowns are not needed.
    - S1 UP NORMAL
      - ◆ This is the slowdown distance for a car traveling Up into all Door Zones.
    - S1 DOWN NORMAL
      - ◆ This is the slowdown distance for a car traveling Down into all Door Zones.
  - S1 MIN RUN DISTANCE
    - Sets the Minimum Run Distance needed to activate the S1 speed profile.
- S2, S3...S8
  - These are separate speed profiles with S1 being the slowest and S8 being the fastest (example: S1 = 50 FPM / S2 = 100 FPM / S3 = 200 FPM / etc.). These profiles contain the same menu selections as S1 above and are set according to job specific speed requirements. Hydros usually only use the S1 profile since the valves are only one speed.
- NUMERIC CMD SPEED
  - When enabled (Yes) this parameter will display the "CMD" speed numerically. Otherwise it will display the commanded speed in English (e.g. High).
  - At the beginning of a run the time between a nonzero speed command and the Brake Pick command.
- ❖ MAIN MENU | SETUP | FLOOR LEVELS |
  - TOO HIGH/TOO LOW
    - This enables the user to set the car to floor level by pressing the up or down arrow keys.
  - DEAD ZONE SIZE
    - This feature sets the maximum distance, in counts, the car is permitted to drift or creep before a re-level command is issued. This parameter should not be changed.
  - RELEVELING
    - When this parameter is enabled (Yes) the controller will correct for out of Dead Zone conditions. Otherwise the controller will not make automatic corrections.
  - RELEVEL DELAY
    - This parameter defines the time the controller will wait before engaging a Relevel command while in a Door Zone's Dead Zone.
  - UP STOP POINTS
    - This parameter permits the user to make advanced adjustments to floor levels. The stop point defined here is the point in the specific floor magnet where the leveling command is removed.
  - DOWN STOP POINTS
    - This parameter permits the user to make advanced adjustments to floor levels. The stop point defined here is the point in the specific floor magnet where the leveling command is removed.



## ❖ MAIN MENU | SETUP | TIMERS

### ➤ BRAKE HOLD TIME

- The time interval between a Brake Pick command and a Brake Hold command.

### ➤ BRAKE DROP (NORM)

- After a Brake Drop command, the time the controller waits before asserting a Brake Drop command in Normal mode.

### ➤ BRAKE DROP (INSP)

- After a Brake Drop command, the time the controller waits before asserting a Brake Drop command in Inspection mode.

### ➤ BRAKE DROP (FAULT)

- After a Brake Drop command, the time the controller waits before asserting a Brake Drop command during a fault condition.

### ➤ DC FIELD ENABLE

- DC Traction controllers only. The time after a run command the controller waits before asserting the DC Field enable output.

### ➤ MOTOR ENERGIZE DELAY

- The duration the controller waits for the motor to become energized.

### ➤ RUN DROP (NORM)

- This timer adjusts the duration of time after the Brake Drop command is given to remove the zero speed command. The drive and controller are still in control of the motor but after the brake has dropped. This timer aids in preventing roll back in Normal mode.

### ➤ RUN DROP (INSP)

- This timer adjusts the duration of time after the Brake Drop command is given to remove the zero speed command. The drive and controller are still in control of the motor but after the brake has dropped. This timer aids in preventing roll back in Inspection mode.

### ➤ RUN DROP (FAULT)

- This timer adjusts the duration of time after the Brake Drop command is given to remove the zero speed command. The drive and controller are still in control of the motor but after the brake has dropped. This timer aids in preventing roll back during a fault condition.

### ➤ SAF DROP DELAY

- At the end of a run, this timer adjusts the time the controller waits to drop the brake after a zero speed command is given.

### ➤ MAX FAULT DELAY

- This timer is how long the controller will try to attempt an orderly stop, or under drive power.

### ➤ SAF REPICK DELAY

- After the Pump Off Delay expires, the amount of time the controller will wait to activate the SF1 relay.

### ➤ MAX RUN TIME

- The maximum time allowed for the motor to run without the car reaching the destination. If this occurs a F114: run too long fault occurs.

### ➤ FAN & LIGHT TIME

- For application with timed cab lighting: this defines the time the controller will keep cab lighting on after a hall or car call.

## ❖ MAIN MENU | SETUP | LEARN MODE COMMANDS |

### ➤ HOMING RUN

- Moves the Car to the DET magnet/switch. If no DET is present the car will hit the buffer.

### ➤ MOVE TO BOTTOM

- Moves the car to DZ magnet below the DET. If no switch is present the car will hit the buffer.

- LEARN MAGNETS
  - Learns the position of all magnets for programmed landings.
- ❖ MAIN MENU | SETUP | DOOR SETUP |
  - MANUAL OPEN AND CLOSE
    - Allows the user to open or nudge the doors closed on any mode of inspection.
  - DOOR DWELL HC
    - The amount of time the controller will wait before asserting door close at the lobby. This time may be canceled by pressing the door close button or a car call button.
  - DOOR DWELL CC
    - The amount of time the controller will wait before asserting door close at a non-lobby landing. May be canceled as above.
  - DOOR DWELL REOPEN
    - The amount of time the controller will wait before asserting the Door Close (DC) command after a reopen command is given.
  - NUDGING TIME
    - The amount of time the controller will permit the photo eye (PHE) to be obstructed before asserting a nudging command. If left at "0" door nudging will be disabled.
  - LOCK CLIP TIME
    - The amount of time the controller will disregard an open hall lock. This prevents intermittent interlock faults and for safety reasons this timer should not exceed .5 seconds.
  - PREOPENING
    - When enabled (Yes) this parameter enables preopening of the doors while the car is leveling and in a Door Zone. Enabled after properly calibrated.
  - NO DEMAND DOOR OPEN
    - Allows the user to keep the car doors open at a landing with no active calls present.
  - DC ON ANY MOVE
    - Applies a squeeze command when the car moves in any direction.
  - DETECT DOOR JUMPERS
    - With this setting enabled (Yes) the controller will check that the gate switch and hall lock inputs mate and de-mate each time a door cycle occurs. *Do not adjust without direction from Smartrise.*
  - TIMEOUT OPEN
    - This timer is the maximum length of time the controller will expect the Door Open Limit (DOL) to activate after issuing a Door Open (DO) command.
  - TIMEOUT CLOSE
    - This timer is the maximum length of time the controller will expect the Door Close Limit (DCL) to activate after issuing a Door Close (DC) command.
  - TIMEOUT NUDGE
    - This timer is the maximum length of time the controller will expect the Door Close Limit (DCL) to activate after issuing a Nudge command.
  - AUTO CLOSE
    - Turns on/off the auto close command (DC) for automatic doors.
  - AUTO OPEN
    - Turns on/off the auto open command (DO) for automatic doors.
  - SWING REOPENS CAR
    - For manual hall swing doors: when enabled (yes) opening the swing door will cause the controller to issue a door reopen command.
  - DC WARNING TIME

- This timer is the amount of time the door close buzzer goes off prior to the controller issuing a Door Close (DC) command.
- DCB CANCELS DWELL
  - When enabled (Yes) “DCB” neglects the door dwell time and closes car doors.
- ANTI-NUI DO W/O PHE
  - How many calls allowed without a break in PHE before cancelling calls.
- NUDGE OUTPUT NORMAL
  - When set to “NO” the Nudge output will be set to Normally Closed (NC).
- ❖ MAIN MENU | SETUP | GROUP SETUP |
  - CAR ID
    - Sets the Controller Car ID. For Group systems this specifies car number. For simplex systems this should default at 000.
  - PARK DELAY TIME
    - Set the amount of time the controller will wait before issuing a park command. If set to “0” the controller will NOT issue a park floor command.
- ❖ MAIN MENU | SETUP | FIRE/EARTHQUAKE |
  - ON SMOKE 1/KEY GO TO
    - Sets the commanded floor when either Smoke 1 trips or when the fire recall key is turned on.
  - ON SMOKE 2 GO TO
    - Sets the commanded floor when Smoke 2 trips.
  - ON SMOKE 3 GO TO
    - Sets the commanded floor when Smoke 3 trips.
  - ON SMOKE 4 GO TO
    - Sets the commanded floor when Smoke 4 trips.
  - RESET TO EXIT PHASE 1
    - When enabled (Yes) a phase 1 key reset is required to return the car to normal operation after the fire recall sequence.
  - LATCH SMOKES
    - If enabled (Yes) a momentary trip of a smoke input will latch Fire Recall. If set to No the controller will return to Normal operation after the Smoke input is remade.
  - LATCH PHASE 1 KEY
    - If enabled (Yes) a momentary contact of the Fire Recall Switch will put the controller in Fire Recall Mode. If disabled (No) the Fire Recall Switch must remain “On” until the car is placed on Fire Phase 2.
  - PHASE 1 BYPASS
    - When enabled (Yes) the controller will permit the fire recall system to be bypassed via a key switch.  
*Do not adjust without Smartrise*
  - DOL TO EXIT PHASE 2
    - When enabled (Yes) the controller will exit phase 2 operation when the DOL is achieved.
  - PH2 DOB MOMENTARY
    - If enabled (Yes), allows user to press “DCB” once instead of holding to close car door.
  - FLASH SMOKE 2
    - Regardless of sequencing, if Smoke 2 is tripped the controller will illuminate the fire hat intermittently as required by group 4 code.
  - FLASH SMOKE 3
    - Regardless of sequencing, if Smoke 3 is tripped the controller will illuminate the fire hat intermittently as required by group 4 code.
  - FLASH SMOKE 4

- Regardless of sequencing, if Smoke 4 is tripped the controller will illuminate the fire hat intermittently as required by group for code.
- COUNTERWEIGHT MID POINT
  - Sets the position at which the counterweight will pass the car.
- ❖ MAIN MENU | SETUP | ACCESS DIST TOP |
  - Sets the allowable distance the car is allowed to travel down on Top Access.
- ❖ MAIN MENU | SETUP | ACCESS DIST BTM |
  - Sets the allowable distance the car is allowed to travel up on Bottom Access.
- ❖ MAIN MENU | SETUP | PI LABELS |
  - This feature permits the user to label any landing to a 2 digit alpha-numeric or numeric configuration.
- ❖ MAIN MENU | SETUP | REAL-TIME CLOCK |
  - TIME
    - This feature sets the internal clock time for fault identification.
  - DATE
    - This feature sets the internal clock date for fault identification.
- ❖ MAIN MENU | SETUP | LOCAL INPUTS |
  - The feature allows the user to see if the Smartrise SRU is registering an input. The inputs are board specific; For example, when looking on the Car Top SRU it will show just the Car Top inputs.
- ❖ MAIN MENU | SETUP | LOCAL OUTPUTS |
  - The feature allows the user to see the programmed output configuration for any Smartrise SRU. For example, if using the Machine Room SRU this would allow the user to see all programmed outputs on the Machine Room Board.
- ❖ MAIN MENU | SETUP | SECURITY |
  - ENABLE CC LOCKOUT
    - When enabled (Yes) input(s) will become actively monitored to secure all car calls. The input requires a 24VC input from the security source.
  - TIMED LOCKOUT HC
    - When enabled (Yes) the controller will lock out all Hall Calls in the programmed time period below.
  - USE FLOOR CODES
    - When enabled (Yes) the user set codes for each floor are now active.
  - IND SRV OVERRIDES
    - When enabled (Yes) Independent Service will override all Car Call security specifications.
  - START TIME (M-F)
    - When timed Hall or Car call is enabled this parameter defines the time of the day Mon-Fri the controller will start locking out the call.
  - STOP TIME (M-F)
    - When timed Hall or Car call is enabled this parameter defines the time of the day Mon-Fri the controller will stop locking out the call.
  - START TIME (S-S)
    - When timed Hall or Car call is enabled this parameter defines the time of the day Sat-Sun the controller will start locking out the call.
  - STOP TIME (S-S)
    - When timed Hall or Car call is enabled this parameter defines the time of the day Sat-Sun the controller will stop locking out the call.
  - PER FLOOR OPTIONS
    - FLOOR # (F) 24/7
      - This parameter turns on security for the front door of Floor # for 24hrs/7days week.

- FLOOR # (R) 24/7
  - This parameter turns on security for the rear door of Floor # for 24hrs/7days week.
- FLOOR # (F) TIMED
  - This parameter turns on security for front door of Floor # based on time of day.
- FLOOR # (R) TIMED
  - This parameter turns on security for rear door of Floor # based on time of day.
- ACCESS CODE (F)
  - This parameter will set an access code to be used for accessing the front door of a security enabled floor.
- ACCESS CODE (R)
  - This parameter will set an access code to be used for accessing the rear door of a security enabled floor.
- ❖ MAIN MENU | SETUP | MISC |
  - BYPASS TERM LIMITS
    - When enabled (Yes) permits the controller to move above or below the bottom and top Door Zone magnets on inspection only.
  - EMERGENCY POWER
    - When set to Yes the controller will monitor an Emergency Power input to determine when to initiate emergency power operation.
  - MONITOR BPS
    - When set to Yes the controller will monitor the brake pick switch on the input it is wired to.  
**CAUTION! Setting this function to No will ignore the brake pick switch which could lead to a dangerous situation, and possibly a fire if the brake doesn't open and the car is still running.**
  - BPS IS N.C.
    - Allows the user to change the input for the brake pick switch from normally open (NO) to normally closed (NC).
  - NUM COP EXP BOARDS
    - This parameter defines how many extra COP boards the controller is expecting. This parameter is only pertinent to specific applications.
  - HOLD WITH PICK
    - Not used for hydraulic applications
  - RESYNC START TIME
    - For hydraulic applications only. This parameter defines the time to initialize the jack re-synchronizing command.
  - RESYNC DURATION
    - For hydraulic applications only. This parameter defines the duration the controller will remain in jack re-synchronization.
  - SABBATH
    - Sets the car to automatically run to every floor, stop, and open the doors.
  - UP VALVE UL WHEN UH
    - This turns on the UPL valve when the UPH valve is actuated (Hydros Only).
- ❖ MAIN MENU | SETUP | DEFAULT ALL |
  - Defaults all parameters to the conditions listed here. If DIP switch one is placed down in conjunction with a default all critical values will be defaulted as well.
- ❖ MAIN MENU | DEBUG |
  - ENTER CAR CALLS
    - Allows the user to input a car call from the Car Top or the Machine Room.

- VIEW MEMORY
  - This is a troubleshooting parameter that is reserved for factory setup. Do not change unless directed by Smartrise.
- ADJUST PARAMETERS
  - These are troubleshooting parameters that are reserved for factory direction. Do not change unless directed by Smartrise.
- BINARY PARAMETERS
  - These are parameters that can be changed by the installer to adjust operation. Refer to Addendum V for a complete list of parameters currently available.
- COMM STATUS
  - This is a troubleshooting parameter that is reserved for factory direction. Do not change unless directed by Smartrise.
- PASSCODE
  - The 5-digit password required to enable Normal Operation. The passcode can be obtained from the Smartrise Accounting Dept.
- ❖ MAIN MENU | SETUP | ABOUT |
  - Describes the controller board, job name and software version the controller is using.

# FAULTS & ALARMS

Each SRU board maintains a log of the  
last 15 faults and alarms.

# DESCRIPTION

Many faults are caused by loose wiring or cables. Check the wiring associated with the fault item before contacting Smartrise. On CAT5 cables, reseal cable in net port making sure that locking tab is fully secure.

Each SRU board maintains a log of the last 15 faults and alarms.

The fault log is maintained even if the controller is powered off.

To view this fault history, navigate to:

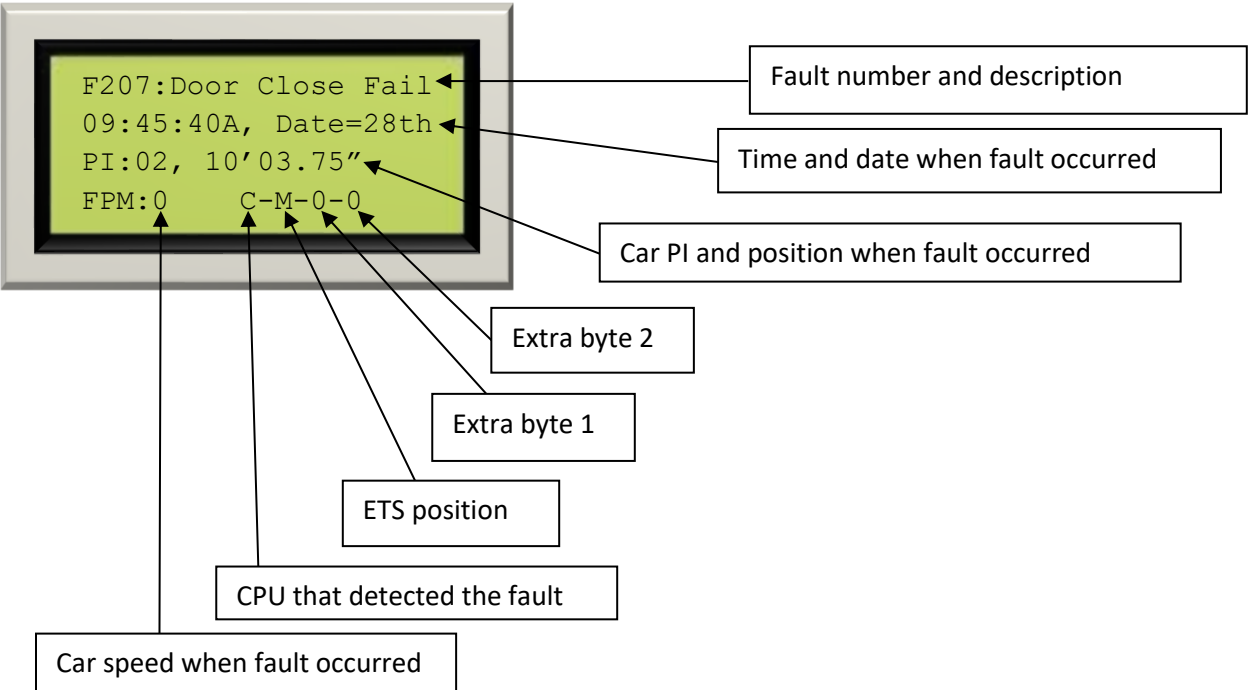
MAIN MENU | FAULTS | LOGGED FAULTS

The fault log is displayed as a list of faults and alarms with the newest faults at the bottom of the list. Scroll up and down to see the list if the last 15 faults and alarms.



To get detailed information on a particular fault or alarm, move the cursor next to that fault and press the ENTER button.

Below is an example of how faults are displayed on the Fault Detail screen.



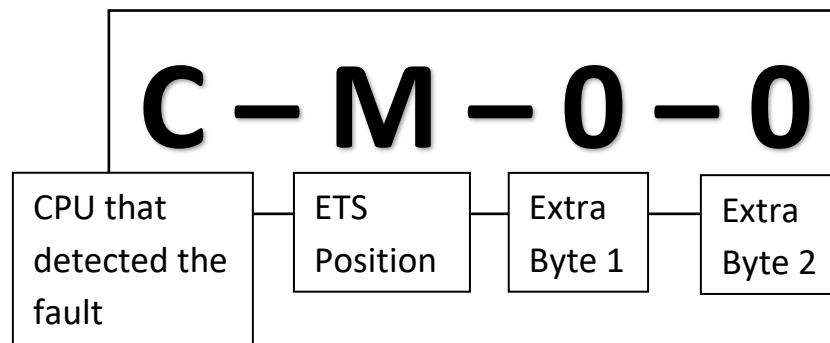


The time and date indicate when the fault was written to the log. It is important that the real-time clock be set properly to have an accurate idea of when the faults occurred.

The PI shows the floor label of the closest doors zone magnet and the position shows feet and inches.

FPM indicates how fast the car was moving.

Four additional indicators on the bottom row show CPU, ETS position, and Extra Bytes 1 and 2.



## Extra Byte Definitions

<i>CPU</i>	<i>Computer that Detected the Fault or Alarm</i>
A	Machine Room SRU, J21 processor
B	Machine Room SRU, J22 processor
C	Cartop SRU, J21 processor
D	Cartop SRU, J22 processor

<i>ETS Position</i>	<i>Meaning</i>	<i>State of ETS Switches when Fault or Alarm Occurred</i>
B	Bottom	DET switch was open, UET switch was closed.
M	Middle	Both DET and UET switches were closed.
T	Top	DET switch was closed, UET switch was open.
U	Unknown	Either DET or UET were both open and the CPU recording the fault did not have accurate information about the state of the switches. Faults that occur shortly after a power on or during a system communication loss may indicate an unknown ETS position.

Extra Byte 1 and Extra Byte 2 are normally both zero indicating that no additional information is available. Several faults and alarms will store additional information in these bytes that can be used to diagnose the cause of the fault.

## Common Fault Clearing Procedures

- DIP SWITCH 1 + RESET – If the Controller gets stuck in a non-normal mode (i.e. Fire Phase I, Earthquake, etc.), verify the required inputs are connected or jumped out, set Dip Switch #1 (Dip A) to ON and then press the RESET button on the SRU board. After pushing RESET turn Dip Switch 1 to off. Latched faults can sometimes be cleared by changing the mode between Normal and Inspection at the machine room controller or car top inspection station.
- ROPE GRIPPER WON'T RESET – Perform “Dip1+Reset” resolution above on cartop SRU board.
- ACTIVE FAULTS – A red LED flashing on the SRU board means a Fault or an Alarm condition exists.
  - a. The faults are logged under MAIN MENU | FAULTS | LOGGED. If the car does not move, look under MAIN MENU | FAULTS | ACTIVE and record the fault number (Fxx).
  - b. When the LCD displays Axx (A57, for example) this indicates an Alarm Condition. This is not an active fault but rather an information message indicating a condition to be addressed.
  - c. When the LCD displays Fxx (F49, for example) this indicates an Active Fault. The car will not run so long as an active fault is present. This condition must be corrected before the car may resume operation.

<b>F2</b>	<b>MS MR Mode</b>	Main/Safety Machine Room Mode fault.
Causes	<p>The J22 processor on the Machine Room SRU board has detected that input 508 is not powered. This indicates that the controller should be either on Inspection or Construction mode. This fault occurs if the J21 processor reports a different operation mode.</p> <p>If a software upgrade has been performed recently then it is possible that one of the SRU boards was mis-programmed.</p>	
Remedies	<p>Verify the wiring on inputs 507 and 508 of the Machine Room SRU board. These inputs should go on and off together as the Machine Room Inspection Enable switch is toggled.</p> <p>Controller boards may need to be reprogrammed if they contain invalid software.</p> <p>Machine Room SRU board may need to be replaced.</p> <p>“MS” faults are often caused by a fast power glitch on an input rather than longer glitches which will cause a “Rdn” F30 fault.</p>	

<b>F4</b>	<b>MS Hall Locks</b>	Main/Safety Hall Locks fault.
Causes	<p>The J22 processor on the Machine Room SRU board has determined the state of the hall door locks by scanning inputs 502, 504, and 506. The J21 processor which scans redundant inputs 501, 503, and 505 reports the hall door locks in a different state.</p> <p>If a software upgrade has been performed recently then it is possible that one of the SRU boards was mis-programmed.</p>	
Remedies	<p>Verify the wiring on inputs 501 through 506 of the Machine Room SRU board. These input pairs [501,502], [503,504], and [505,506] should go on and off together as the bottom, middle, and top hall locks open and close.</p> <p>Controller boards may need to be reprogrammed if they contain invalid software.</p> <p>Machine Room SRU board may need to be replaced.</p> <p>“MS” faults are often caused by a fast power glitch on an input rather than a longer glitch which will cause a “Rdn” F39-F41 fault.</p>	

F6	Safety String	Safety String has caused a contactor to not close.
Causes	<p>The feedback from the M, B1 or B2 contactors shows a contactor in the open position when it should be closed. Use Extra Byte 1, 2 or 3 to determine the reason for the fault and how to correct it.</p> <p>Extra Bytes 1-0: Both SF1 and SF2 are energized but the M contactor feedback shows it open (de-energized). The M contactor should close (energize) whenever the safety string is made and the SAF relays are both energized.</p> <p>The machine room board monitors the normally closed auxiliary contact of the M contactor. This contact is normally wired to an input on the Machine Room SRU board but can be moved to another input. The input should be powered when the contactor is open and unpowered when the contactor is closed.</p> <p>Extra Bytes 2-0: The controller has been asserting a pick or hold command to the brake for at least one second but one or more of the B1 contactors feedback show they are not energized.</p> <p>Extra Bytes 3-0: The controller has been asserting a pick or hold command to the brake for at least one second but one or more of the B2 contactors feedback show they are not energized.</p>	
Remedies	<p><u>Extra Bytes 1-0:</u> If the M contactor does not energize at all, check the safety circuit for an open switch. The coil of the M contactor gets its power from the safety circuit.</p> <p>Also check the SF1 and SF2 relays. Verify the relays are properly seated in the sockets and do not have any bent pins.</p> <p>If the M contactor does energize, verify the normally closed feedback input on the Machine Room SRU board is powered when contactor is de-energized, and not powered when contactor is energized.</p> <p>Verify the auxiliary contactor is securely attached to the M contactor. If the connection is loose, try to snap it back on more snugly.</p> <p><u>Extra Bytes 2-0:</u> If the B1 contactor does energize, verify that the normally open feedback inputs on the Machine Room SRU board are powered when contactor is de-energized and not powered when contactor is energized.</p> <p>Verify the auxiliary contactor is securely attached to the B1 contactors. If a connection is loose, try to snap it back on more snugly.</p> <p><u>Extra Bytes 3-0:</u> If the B2 contactor does energize, verify that the normally open feedback inputs on the Machine Room SRU board are powered when contactor is de-energized and not powered when contactor is energized.</p> <p>Verify the auxiliary contacts are securely attached to the B2 contactors. If a connection is loose, try to snap it back on more snugly.</p>	

<b>F7</b>	<b>MS ETS Zone</b>	Main/Safety ETS Zone fault
Causes	<p>The J22 processor on the Machine Room SRU board has determined the state of the ETS hoistway switches by scanning inputs 510 and 512. The J21 processor which scans redundant inputs 509 and 511 reports the switches in a different position.</p> <p>If a software upgrade has been performed recently then it is possible that one of the SRU boards was mis-programmed.</p>	
Remedies	<p>Verify the wiring on inputs 509 through 512 of the Machine Room SRU board. The input pairs [509,510] and [511,512] should go on and off together as the car passes the UET and DET hoistway switches.</p> <p>Controller boards may need to be reprogrammed if they contain invalid software.</p> <p>Machine Room SRU board may need to be replaced.</p> <p>“MS” faults are often caused by a fast power glitch on an input rather than a longer glitch which will cause a “Rdn” F35-F36 fault.</p>	

<b>F8</b>	<b>MSM GSW</b>	Main/Safety Gate Switch fault.
Causes	<p>The J22 processor on the Cartop SRU board has determined the state of the gate switch by scanning input 508 (and 515 if car has rear doors). The J21 processor which scans redundant inputs 507 and 514 reports the switches in a different position.</p> <p>If a software upgrade has been performed recently then it is possible that one of the SRU boards was mis-programmed.</p>	
Remedies	<p>Verify the wiring on inputs 507 and 508 (and 514 and 515 if car has rear doors) of the Cartop SRU board. The input pairs [507,508] and [514,515] (if rear doors) should go on and off together as the car doors open and close.</p> <p>Controller boards may need to be reprogrammed if they contain invalid software.</p> <p>Cartop SRU board may need to be replaced.</p> <p>“MS” faults are often caused by a fast power glitch on an input rather than a longer glitch which will cause a “Rdn” F37 or F56 fault.</p>	

<b>F9</b>	<b>SAF1 Open Fail</b>	<b>Safety Relay SAF1 Failed to Open</b>
Causes	<p>The controller is trying to de-energize (open) safety relay SF1 but the feedback from the relay shows that it is still energized (closed).</p> <p>Output 601 on the Machine Room SRU board controls the coil of the relay. Input 520 is the normally closed feedback monitor.</p> <p>When 601 is off, 520 should be on. If 520 reports the wrong state for more than 1 second then this fault is logged.</p>	
Remedies	<p>Check to see if the SF1 relay is properly seated in the socket and does not have any bent pins.</p> <p>Check Jumper J19 (Rev 5-7 SRU) and J24 (Rev 8 SRU) for proper configuration. Refer to provided drawings.</p> <p>Check MAIN MENU   STATUS   IO   INPUT GROUPS   CONTROLLER   SAF1 to see if the status is changing with Output 601.</p> <p>Check wiring for 601 / 520.</p>	

<b>F10</b>	<b>SAF2 Open Fail</b>	<b>Safety Relay SAF2 Failed to Open</b>
Causes	<p>The controller is trying to de-energize (open) safety relay SF2 but the feedback from the relay shows that it is still energized (closed).</p> <p>Output 601 on the Cartop SRU board controls the coil of the relay. Input 526 is the normally closed feedback monitor.</p> <p>When 601 is off, 526 should be on. If 526 reports the wrong state for more than 1 second then this fault is logged.</p>	
Remedies	<p>Check the SF2 relay. Verify it is properly seated in the socket and does not have any bent pins.</p> <p>Check Jumper J19 (Rev 5-7 SRU) and J24 (Rev 8 SRU) for proper configuration. Refer to provided drawings.</p> <p>Check MAIN MENU   STATUS   IO   INPUT GROUPS   CONTROLLER   SAF2 to see if the status is changing with Output 601.</p> <p>Check wiring for 601 / 526.</p>	

F11	B Cont. Fail	B Contactor Failed to Open
Causes	<p><u>Extra Bytes 2-0</u>: B1 Contactor auxiliary contact indicates the B1 is energized (closed) when it should be de-energized (open).</p> <p><u>Extra Bytes 3-0</u>: B2 Contactor auxiliary contact indicates the B2 is energized (closed) when it should be de-energized (open).</p>	
Remedies	<p><u>Extra Bytes 2-0</u>: Check that the B1 contactor de-energizes (opens) when there is no demand to run.</p> <p>Check the auxiliary contact on B1. Verify it is properly seated on the contactor and that no wires have become loose or disconnected.</p> <p>Check input terminal on Machine Room SRU board to verify that the wire has not become loose or disconnected.</p> <p>Check door data to see if all interlocks are being made.</p> <p><u>Extra Bytes 3-0</u>: Check that the B2 contactor de-energizes (opens) after relays RGM and DZM de-energize.</p> <p>Check the auxiliary contact on B2. Verify it is properly seated on the contactor and that no wires have become loose or disconnected.</p> <p>Check input terminal on Machine Room SRU board to verify that the wire has not become loose or disconnected.</p> <p>Check door data to see if all interlocks are being made.</p>	
F12	M Cont. Fail	M Contactor Failed to Open
Causes	The M contactor failed to open.	
Remedies	<p>Check that the M contactor de-energizes (opens) when SF1 relay is de-energized.</p> <p>Check the auxiliary contact on M contactor. Verify it is properly seated on the contactor and that no wires have become loose or disconnected.</p> <p>Check input terminal on Machine Room SRU board to verify that the wire has not become loose or disconnected.</p>	

F13	MS CT Mode	Main/Safety Mode Fault
Causes	<p>The J22 processor on the Cartop SRU board has scanned inputs 504 and 506 (and 513 if In-Car Inspection option is enabled) to determine if car is on inspection or in automatic mode. The J21 processor has scanned redundant inputs 503 and 505 (and 512 if IC inspection) and determined a different mode of operation.</p> <p>If a software upgrade has been performed recently then it is possible that one of the SRU boards was mis-programmed.</p>	
Remedies	<p>Verify the wiring on inputs 503 through 506 (and 512 and 513 if IC inspection). The input pairs [503,504] and [505,506] (and [512, 513] if IC inspection) should go on and off together as the various inspection/access enable switches are toggled on and off.</p> <p>Controller boards may need to be reprogrammed if they contain invalid software.</p> <p>Cartop SRU board may need to be replaced.</p> <p>“MS” faults are often caused by a fast power glitch on an input rather than a longer glitch which will cause a “Rdn” F31, F32, or F38 fault.</p>	

F22	Gate Switch	GSW, DCL or DPM not flagging in Normal Operation
Causes	<p><u>Extra Bytes 0-0</u> (any door): Controller was trying to close or nudge the doors and timed out before seeing GSW, DPM and DCL.</p> <p>All three signals (GSW, DPM, DCL) have to be flagged in Normal Operation.</p> <p>Car is on inspection, GSW is not made, and the Car Door Bypass enable switch is not active.</p> <p>Car is outside of a door zone and the GSW is not made.</p> <p><u>Extra Bytes 1-0</u> (front door): The GSW input for the front (or only) door is not powered, the car is not in a door zone, and the current operating mode does not allow for running with the car doors open.</p> <p><u>Extra Bytes 2-0</u> (rear door): Same as above but for rear door.</p> <p><u>Extra Bytes 3-0</u> (any door): Controller detected no GSW for at least 500ms while outside a door zone and exceeding 20 fpm.</p>	
Remedies	<p><u>Extra Bytes 0-0</u> (any door): Check inputs for GSW, DPM, and DCL. Verify they are transition properly as car door is opened and closed.</p> <p>If DPM is not flagging, jump it to the GSW inputs so it flags at the same time as GSW.</p> <p>If car is on inspection and needs to be moved then either close the car doors or activate the Car Door Bypass Enable switch. Note that the bypass switch will not work on Machine Room Inspection.</p> <p>A bad door zone magnet may cause the controller to lose the DZ input while stopped at a floor. If this happens while the doors are open this fault will be logged.</p> <p><u>Extra Bytes 1-0</u> (front door): Verify that the front car door is closed.</p> <p>Verify that the GSW circuit is operating correctly.</p> <p>Verify that the door zone sensor and magnets are working.</p> <p><u>Extra Bytes 2-0</u> (rear door): Same as above but for rear door.</p> <p><u>Extra Bytes 3-0</u> (any door): Check gate switch and wiring.</p>	



F23	Hall Locks	Hall Lock or Swing Door Closed fault.
Causes	<p>This fault will occur when a hall door lock is clipped or open during car operation. Two faults may be logged for each occurrence, one for CPU A &amp; one for CPU B. Both faults will have the same Extra Byte 1.</p> <p>Extra Bytes = CPU – Location at time of fault – Extra Byte 1 – Extra Byte 2</p> <p>CPU: A or B</p> <p>Location: T = Top floor, M = Middle Floors, B = Bottom floor</p> <p><b><u>Automatic Doors</u></b></p> <p><b><u>Extra Byte 1:</u></b> 27 = Top Lock Open, 45 = Middle Lock Open, 54 = Bottom Lock Open</p> <p><b><u>Manual Doors</u></b></p> <p><b><u>Extra Byte 1:</u></b> 31 = Top Close Switch Open, 47 = Middle Close Switch Open, 55 = Bottom Close Switch Open 59 = Top Hall Lock Open, 61 = Middle Hall Lock Open, 62 = Bottom Hall Lock Open</p> <p><b><u>All Doors</u></b></p> <p><b><u>Extra Byte 2:</u></b> CPU A records in increments of 1, CPU B records in increments of 10</p> <p>Example: A–B–45–10 = CPU A, At Bottom Landing, Middle Lock Open, Lasted 10ms</p> <p>Extra Byte 1 holds the hall door flags at the time of the fault.</p> <p>Extra Byte 2 holds the time (in 10ms ticks) that the doors were in an unsafe position prior to generating the fault.</p> <p>CPU: A: Attempting to move car on inspection with one or more hall locks open and Bypass Hall Doors Enable switch off.</p> <p>Car is on Hoistway Access and the middle lock or closed input in not powered.</p> <p>Car was running and clipped a door lock.</p> <p>Car doors are closed and car is attempting to run for at least 5 seconds but hall locks have not yet made.</p> <p>CPU: B: One or more locks were not made for more than 500ms at a time when all locks should be made.</p>	
Remedies	<p>CPU: A: Using the Extra Bytes determine which lock was open at time of fault.</p> <p>Try increasing the LOCK CLIP TIME under the DOOR SETUP menu.</p> <p>Check hall locks and wiring.</p> <p>CPU: B: Check hall locks and wiring.</p>	

F24	In Car Stop	In-Car Stop Switch in Stop Position
Causes	<p>The In-Car Stop switch is in the Stop position.</p> <p>The In-Car stop switch inputs on the SRU board are not powered or switch is wired incorrectly (reversed).</p> <p>The In-Car Stop switch is not present on car but inputs have not been jumped out.</p>	
Remedies	<p>Turn the In-Car Stop switch to the RUN position.</p> <p>Both inputs on the SRU board must be powered for the car to run. Verify that the In-car Stop switch is wired to both these inputs.</p> <p>Verify the inputs have power when the switch is in the RUN position and that power is removed in the STOP position.</p> <p>If car does not have an In-car Stop switch then the Cartop SRU inputs must be jumped to the C24 bus.</p>	

F27	Drive Comm	No Serial Communication with Drive
Causes	<ol style="list-style-type: none"> <li>1. CAT5 cable not plugged into <u>DRIVE</u> port.</li> <li>2. Smartrise drive parameter not configured for serial control of drive.</li> <li>3. Jumpers on Machine Room SRU board connector J20 set for half-duplex communication on DRIVE port.</li> <li>4. Bad CAT5 communication cable.</li> <li>5. Magnetek drive not configured for serial communication.</li> <li>6. Bad comport on Machine Room SRU board.</li> <li>7. Excessive electrical noise or bad grounding.</li> <li>8. Bad Comm port on Magnetek drive.</li> </ol>	
Remedies	<ol style="list-style-type: none"> <li>1. Reseat CAT5 communication cable into DRIVE port.</li> <li>2. Verify parameter 00-020 = xFF for Magnetek / Verify parameter 00-020 = xFC for Hydros</li> <li>3. Verify there are no jumpers on Machine Room SRU board 10-pin header J20. This header is located at top left corner of SRU board.</li> <li>4. Replace CAT5 drive cable.</li> <li>5. Verify Magnetek drive is configured for serial communication.</li> <li>6. Replace Machine Room SRU board.</li> <li>7. Be sure controller is properly grounded.</li> <li>8. Replace Magnetek drive.</li> </ol>	

F29	Out of Service	Car will no longer run on Automatic operation.
Causes	<p>Use Extra Byte 1 and Extra Byte 2 to determine the reason for the fault and how to correct it.</p> <p><u>Extra Bytes 0-2:</u> Hydro is in a “Can’t Run Up” condition. This is a condition where it cannot run the pump motor. This can be due to low oil, running on battery power, or having exceeded the motor limit timer (MLT).</p> <p><u>Extra Bytes 1-0:</u> Car has exceeded the maximum number of <i>Starts Per Minute</i>.</p> <p>Parameter 00-042 limits how many times the controller may attempt to run the car in a one-minute period. If the safety logic detects too many attempts, it will take the car out of service until the minute field on the real-time clock changes.</p> <p><u>Extra Bytes 2-0:</u> Car has exceeded the maximum number of <i>Faults Per Hour</i>.</p> <p>Parameter 00-041 limits how many times the controller may fault in a one-hour period. If the safety logic detects too many faults, it will take the car out of service until the hour field on the real-time clock changes.</p> <p><u>Extra Bytes 4-0:</u> Manual reset required per TSSA code.</p> <p><u>Extra Bytes 7-N</u> – Where N is floor (1 = bottom): Car has gone out of service due to activation of the HUGS infant abduction security system at a floor the car was serving.</p> <p><u>Extra Bytes 8-8:</u> An <i>Out of Service</i> input has been activated on one of the SRU boards. An out of service input will appear under <i>Local Inputs</i> as [CONTROLLER, GO OOS].</p> <p><u>Extra Bytes 9-9:</u> The <i>Out of Service Timer</i> is activated and took the car out of service.</p>	

Remedies	<p><u>Extra Bytes 0-2:</u> Correct the condition preventing the car from running the pump motor. You may also need to toggle the car on and off of inspection to manually clear the fault.</p> <p><u>Extra Bytes 1-0:</u> Verify parameter 00-042 has a valid value. By default, the car is allowed to make 10 runs per minute. If the value is too small this fault may occur.</p> <p>Check that the real-time clock is set and working. Navigate to MAIN MENU   SETUP   REAL-TIME CLOCK   TIME. If the time is wrong, set it. If the time is correct, watch until the seconds reaches 59. Verify the minute value increments when the seconds rolls over to 00. If it does not the clock chip may need to be replaced.</p> <p>To prevent this fault from occurring, you can set parameter 00-042 = x00. This should only be done if the real-time clock is not working and a replacement is not immediately available.</p> <p><u>Extra Bytes 2-0:</u> During installation or testing, an excessive number of faults may be generated. You can set parameter 00-041 = x00 to disable this fault however it is recommended that you set it back to a non-zero number once the car is placed into normal operation.</p> <p>Check that the real-time clock is set and working. Navigate to MAIN MENU   SETUP   REAL-TIME CLOCK   TIME. If the time is wrong, set it. If the time is correct, verify that the hour value increments when the minutes rolls over from 59 to 00. If it does not the clock chip may need to be replaced. Set parameter 00-041 = x00 until the clock chip can be replaced.</p> <p><u>Extra Bytes 4-0:</u> Reset the controller via key switch or DIP #1 + RESET.</p> <p><u>Extra Bytes 7-N:</u></p> <p>Reset of the HUGS security system is required to put the car back in service.</p> <p><u>Extra Bytes 8-8:</u> If the controller has external circuitry for taking the car out of service, check if it is functioning properly. The SRU input should be off for normal operation, on to take car out of service.</p> <p>Check the <i>Local Inputs</i> of each SRU board to see if any input is incorrectly assigned for the out of service function.</p> <p><u>Extra Bytes 9-9:</u> The Out of Service Timer is under the MAIN MENU   DEBUG   OOS menu. To put the car back in service, the appropriate OOS LOCK CODE must be entered. Contact Smartrise for additional assistance if the lock code is not known.</p>
----------	---

<b>F30</b>	<b>Rdn Insp MR</b>	
Causes	<p>This fault is related to safety critical inputs that come in on two input terminals. A fault occurs when one input is on and the other is off.</p> <p>Mismatch on MR input pair</p>	
Remedies	<p>Check for wiring mistakes on the inputs terminals.</p> <p>Check for plug-in terminal blocks on SRU board that might be defective.</p> <p>Verify input LEDs go on and off together. If LEDs do go on and off together, check SRU board for metal shavings or anything that might be grounding or shorting the components on the board.</p> <p>Replace SRU board.</p>	

<b>F31</b>	<b>Rdn Insp CT</b>	
Causes	<p>This fault is related to safety critical inputs that come in on two input terminals. A fault occurs when one input is on and the other is off.</p> <p>Mismatch on CT input pair</p>	
Remedies	<p>Check for wiring mistakes on the inputs terminals.</p> <p>Check for plug-in terminal blocks on SRU board that might be defective.</p> <p>Verify input LEDs go on and off together. If LEDs do go on and off together, check SRU board for metal shavings or anything that might be grounding or shorting the components on the board.</p> <p>Replace SRU board.</p>	

<b>F32</b>	<b>Rdn Insp IC</b>	
Causes	<p>This fault is related to safety critical inputs that come in on two input terminals. A fault occurs when one input is on and the other is off.</p> <p>Mismatch on CT input pair or controller was configured for In-car Inspection but car does not have IC Inspection key switch.</p>	
Remedies	<p>Check for wiring mistakes on the inputs terminals.</p> <p>Check for plug-in terminal blocks on SRU board that might be defective.</p> <p>Verify input LEDs go on and off together. If LEDs do go on and off together, check SRU board for metal shavings or anything that might be grounding or shorting the components on the board.</p> <p>Replace SRU board.</p> <p>For fault F32 only, if car does not have an In-car Inspection key switch then set parameter 00-004 = x51 to disable this feature.</p>	

<b>F33</b>	<b>Rdn IC Stop</b>	
Causes	<p>This fault is related to safety critical inputs that come in on two input terminals. A fault occurs when one input is on and the other is off.</p> <p>Mismatch on CT input pair</p>	
Remedies	<p>Check for wiring mistakes on the inputs terminals.</p> <p>Check for plug-in terminal blocks on SRU board that might be defective.</p> <p>Verify input LEDs go on and off together. If LEDs do go on and off together, check SRU board for metal shavings or anything that might be grounding or shorting the components on the board.</p> <p>Replace SRU board.</p>	

<b>F35</b>	<b>Rdn UET</b>	
Causes	<p>This fault is related to safety critical inputs that come in on two input terminals. A fault occurs when one input is on and the other is off.</p> <p>Mismatch on MR input pair</p>	
Remedies	<p>Check for wiring mistakes on the inputs terminals.</p> <p>Check for plug-in terminal blocks on SRU board that might be defective.</p> <p>Verify input LEDs go on and off together. If LEDs do go on and off together, check SRU board for metal shavings or anything that might be grounding or shorting the components on the board.</p> <p>Replace SRU board.</p>	

<b>F36</b>	<b>Rdn DET</b>	
Causes	<p>This fault is related to safety critical inputs that come in on two input terminals. A fault occurs when one input is on and the other is off.</p> <p>Mismatch on MR input pair</p>	
Remedies	<p>Check for wiring mistakes on the inputs terminals.</p> <p>Check for plug-in terminal blocks on SRU board that might be defective.</p> <p>Verify input LEDs go on and off together. If LEDs do go on and off together, check SRU board for metal shavings or anything that might be grounding or shorting the components on the board.</p> <p>Replace SRU board.</p>	

<b>F37</b>	<b>Rdn GSW (F)</b>	
Causes	<p>This fault is related to safety critical inputs that come in on two input terminals. A fault occurs when one input is on and the other is off.</p> <p>Mismatch on CT input pair</p>	
Remedies	<p>Check for wiring mistakes on the inputs terminals.</p> <p>Check for plug-in terminal blocks on SRU board that might be defective.</p> <p>Verify input LEDs go on and off together. If LEDs do go on and off together, check SRU board for metal shavings or anything that might be grounding or shorting the components on the board.</p> <p>Replace SRU board.</p>	

<b>F38</b>	<b>Rdn Access</b>	
Causes	<p>This fault is related to safety critical inputs that come in on two input terminals. A fault occurs when one input is on and the other is off.</p> <p>Mismatch on CT input pair</p>	
Remedies	<p>Check for wiring mistakes on the inputs terminals.</p> <p>Check for plug-in terminal blocks on SRU board that might be defective.</p> <p>Verify input LEDs go on and off together. If LEDs do go on and off together, check SRU board for metal shavings or anything that might be grounding or shorting the components on the board.</p> <p>Replace SRU board.</p>	

<b>F39</b>	<b>Rdn Top Lock</b>	
Causes	<p>This fault is related to safety critical inputs that come in on two input terminals. A fault occurs when one input is on and the other is off.</p> <p>Mismatch on MR input pair</p>	
Remedies	<p>Check for wiring mistakes on the inputs terminals.</p> <p>Check for plug-in terminal blocks on SRU board that might be defective.</p> <p>Verify input LEDs go on and off together. If LEDs do go on and off together, check SRU board for metal shavings or anything that might be grounding or shorting the components on the board.</p> <p>Replace SRU board.</p>	

<b>F40</b>	<b>Rdn Intr Lock</b>	
Causes	<p>This fault is related to safety critical inputs that come in on two input terminals. A fault occurs when one input is on and the other is off.</p> <p>Mismatch on MR input pair</p>	
Remedies	<p>Check for wiring mistakes on the inputs terminals.</p> <p>Check for plug-in terminal blocks on SRU board that might be defective.</p> <p>Verify input LEDs go on and off together. If LEDs do go on and off together, check SRU board for metal shavings or anything that might be grounding or shorting the components on the board.</p> <p>Replace SRU board.</p>	

<b>F41</b>	<b>Rdn Btm Lock</b>	
Causes	<p>This fault is related to safety critical inputs that come in on two input terminals. A fault occurs when one input is on and the other is off.</p> <p>Mismatch on MR input pair</p>	
Remedies	<p>Check for wiring mistakes on the inputs terminals.</p> <p>Check for plug-in terminal blocks on SRU board that might be defective.</p> <p>Verify input LEDs go on and off together. If LEDs do go on and off together, check SRU board for metal shavings or anything that might be grounding or shorting the components on the board.</p> <p>Replace SRU board.</p>	

<b>F47</b>	<b>Main&lt;-&gt;Saf MR</b>	
Causes	<p>These faults will occur normally during an upgrade of the system software since the CPUs are halted during programming.</p> <p>If these faults occur during normal operation then it may indicate a bad board.</p>	
Remedies	<p>It is probably safe to ignore this fault if it occurred during SRU programming.</p> <p>Replace the Machine Room SRU board.</p>	

<b>F48</b>	<b>Main&lt;-&gt;Saf CT</b>	
Causes	<p>These faults will occur normally during an upgrade of the system software since the CPUs are halted during programming.</p> <p>If these faults occur during normal operation then it may indicate a bad board.</p>	
Remedies	<p>It is probably safe to ignore this fault if it occurred during SRU programming.</p> <p>Replace the Cartop SRU board.</p>	



<b>F49</b>	<b>Drive Fault</b>	A Fault has occurred on the drive or a fault on the controller has registered as a drive fault.
Causes	<p>A drive fault can sometimes be the result of an emergency stop due to another fault.</p> <p>On hydraulic systems a softstart fault has occurred either from the fault contactor not closing or an actual drive fault.</p> <p>On traction systems an encoder that is connected wrong can often cause a drive fault.</p>	
Remedies	<p>Check the Smartrise fault log to see if another fault occurred at the same time as the drive fault. This may be the actual fault and the drive fault was just a result of the emergency stop.</p> <p>Check the softstart for faults and refer to the softstart manual for troubleshooting codes and corrections.</p> <p>Check the fault history on the drive itself. This will give additional details as to what caused the drive to fault.</p>	

<b>F52</b>	<b>Overspeed Cmd</b>	Attempt to Command Drive to Run at Illegal Speed
Causes	<p>Inspection speed or Leveling speed set to a value greater than 150 fpm.</p> <p>One of the run speeds set greater than 110% of Contract Speed.</p>	
Remedies	Verify car speed parameters (S1-S3) are set with the values included on provided drawings.	

<b>F53</b>	<b>Fault Log Cleared</b>	All faults stored in memory have been automatically erased
Causes	<p>During power up of the controller, the software validates that the memory used to store the fault log is valid. An F53 fault is thrown and the fault log memory is cleared if it is found to contain invalid data.</p> <p>A new SRU board that has not been powered on may have invalid data in the area of memory used to store faults.</p> <p>Reprogramming an SRU with a new software version may cause the fault log to get cleared.</p> <p>If the controller lost power or an SRU board was reset during the recording of a fault, the log data may become invalid and have to be cleared.</p> <p>If the F53 fault happens every time the controller is powered up, it probably means that the battery that provides power to the Real-Time Clock chip is dead. This is the large chip in the center of the SRU board. It keeps track of time when the controller is powered off and also stores the fault log in RAM.</p>	
Remedies	<p>With the exception of a dead RTC chip battery, an occasional F53 should not be a problem.</p> <p>If you suspect a dead battery, you will need to replace the RTC chip. Most SRU boards manufactured after 2009 have this chip socketed. If your board has the chip soldered, you will need to replace the board.</p> <p>It is perfectly safe to run the elevator with a dead battery in the RTC chip. It simply means that the fault log will be erased if you lose power. Also, any functions that require knowing the time and date (e.g. timed security) may not function properly after a power loss.</p>	

<b>F56</b>	<b>Rdn GSW (R)</b>	
Causes	<p>This fault is related to safety critical inputs that come in on two input terminals. A fault occurs when one input is on and the other is off.</p> <p>Mismatch on CT input pair</p>	
Remedies	<p>Check for wiring mistakes on the inputs terminals.</p> <p>Check for plug-in terminal blocks on SRU board that might be defective.</p> <p>Verify input LEDs go on and off together. If LEDs do go on and off together, check SRU board for metal shavings or anything that might be grounding or shorting the components on the board.</p> <p>Replace SRU board.</p>	

<b>F71</b>	<b>Speed Dev Err</b>	Speed deviation error
Causes	<p>The detected car speed is different from the expected value.</p>	
Remedies	<p>Check for proper connection of DP1 and DP2 signals. Verify the DP1 and DP2 inputs on the CT SRU toggle rapidly back &amp; forth as the car moves.</p> <p>IP8300:</p> <p>Verify the CAT5 connection cable between the IP8300 breakout board and the selector head has not come loose or disconnected. Reseat cable. Make sure the CAT5 cable is a standard cable and not a modified or crossover cable.</p> <p>Encoder:</p> <p>Verify that the encoder has not become loose or disconnected. Check the encoder speed feedback in the drive to determine if it's reading accurately.</p>	

<b>F75</b>	<b>Overspeed FPM</b>	Actual Overspeed of Car Detected
Causes	<p>True car speed exceeded 110% of Contract Speed.</p> <p>True car speed exceeded 150 fpm while on Inspection.</p>	
Remedies	<p>Be sure Contract Speed parameter is set correctly to maximum speed at which the car will run.</p> <p>For hydraulic cars, high speed inspection may cause car to over speed.</p> <p>For traction cars, check contract motor speed on drive. Reduce the RPM value if necessary.</p>	

<b>F77</b>	<b>CPU Stop Swch</b>	CPU Stop Switch is Active
Causes	<p>A or B: DIP switch 1 on Machine Room SRU board is in the ON position.</p> <p>C or D: DIP switch 1 on Cartop SRU board is in the ON position.</p>	
Remedies	<p>Turn switch to OFF position to enable car to run.</p> <p>Turn switch to OFF position to enable car to run.</p>	

<b>F80</b>	<b>DETS Overspeed</b>	Overspeed of Car at DET switch.
Causes	<p><u>Extra Bytes A or B</u> : Commanded car speed was 95% of Contract Speed as car crossed an ETS switch while approaching the terminal.</p> <p><u>Extra Bytes C or D</u> : Actual detected car speed was 95% of Contract Speed as car crossed an ETS switch while approaching the terminal.</p>	
Remedies	<p>Increase the slowdown distance parameters.</p> <p>Move the ETS switch that caused the fault closer to the terminal.</p> <p>Increase the slowdown distance parameters.</p> <p>Move the ETS switch that caused the fault closer to the terminal.</p>	
<b>F81</b>	<b>UETS Overspeed</b>	Overspeed of Car at UET switch.
Causes	<p><u>Extra Bytes A or B</u> : Commanded car speed was 95% of Contract Speed as car crossed an ETS switch while approaching the terminal.</p> <p><u>Extra Bytes C or D</u> : Actual detected car speed was 95% of Contract Speed as car crossed an ETS switch while approaching the terminal.</p>	
Remedies	<p>Increase the slowdown distance parameters.</p> <p>Move the ETS switch that caused the fault closer to the terminal.</p> <p>Increase the slowdown distance parameters.</p> <p>Move the ETS switch that caused the fault closer to the terminal.</p>	
<b>F91</b>	<b>Learn Error</b>	Learn Error
Causes	<p>The LEARN MAGNETS command was given when car was not in the bottom door zone. Controller must see DZ on, DET off, and UET on to begin the learn process.</p>	
Remedies	<p>Verify the LEARN MAGNETS command is given only when car is at bottom door zone.</p> <p>Verify the door zone input is correctly wired and magnets are reading properly.</p> <p>Verify DET and UET are installed correctly and do not overlap with any door zone magnets.</p>	

F100	CN 0	Loss of communication between Machine Room and Cartop
Causes	<p>CN+ and CN- wires in traveling cable not properly connected.</p> <p>Machine room REF terminal not connected to Cartop REF terminal.</p> <p>Shield on communication cable not connected to REF at <u>both</u> ends.</p> <p>CAT5 cable between Cartop and COP board not properly connected.</p> <p>Factory “pig tail” CAT5 cables loose in machine room or cartop.</p> <p>Either the Machine Room SRU board or the Cartop SRU board is not powered.</p>	
Remedies	<p>Verify the CN+ terminal in the machine room connects to the CN+ terminal on the cartop.</p> <p>Verify the CN- terminal in the machine room connects to the CN- terminal on the cartop.</p> <p>Verify the REF terminal in the machine room connects to the REF terminal on the cartop.</p> <p>Verify the N terminal in the machine room connects to the N terminal on the cartop.</p> <p>Verify the GND terminal in the machine room connects to the GND terminal on the cartop.</p> <p>Verify the CN+ / CN- pair is shielded and that the shield is connected to REF at <u>both</u> ends.</p> <p>Check communication status of J21:U0 under MAIN MENU   DEBUG   COMM STATUS. It should normally be 100% at all times. If it is 100% but then drops when the car runs, it is most likely a grounding problem.</p> <p>Unplug the CAT5 cable that goes from the cartop to the COP board. If the F100 fault goes away with the cable unplugged it may be a bad cable. It might also be that the cable is plugged into the wrong comport. Verify the CAT5 goes from NET on the Cartop board to NET on the COP board. For best results, a CAT5 cable with the orange pair cut should be used.</p> <p>Bring the Cartop SRU board to the machine room and connect it directly to the Machine Room SRU board. You will need to connect CN+, CN-, M24, and REF. If you have a standard CAT5 cable<sup>1</sup> you can connect it from the MR NET port to the CT NET port. This will provide both power and CN signals. If the F100 fault goes away during this test then there is a problem in the wiring. If the F100 fault persists then one or both of the SRU boards is damaged.</p> <p><sup>1</sup> A standard PC CAT5 cable must be used. The CAT5 cable provided by Smartrise to link the Cartop and COP SRU boards usually has the internal orange pair cut and will not work for this test.</p>	

<b>F111</b>	<b>Closing SAF1</b>	Safety Relay SAF1 Failed to Close
Causes	<p>Rev 5-7 Boards: Jumper J19 on the Machine Room SRU board may be in the wrong position.</p> <p>Rev 8+ Boards: Jumper J24:1 on the Machine Room SRU board may be in the wrong position.</p> <p>All: The controller is trying to energize (close) safety relay SAF1 but the feedback from the relay shows that it is still de-energized (open). Output 601 on the Machine Room SRU board controls the coil of the relay. Input 520 is the normally closed feedback monitor. When 601 is on, 520 should be off. If 520 reports the wrong state for more than 1 second then this fault is logged.</p>	
Remedies	<p>Rev 5-7 Boards: Verify the jumper on J19 shunts the upper two posts (pins 2 and 3).</p> <p>Rev 8+ Boards: Verify the jumper on J24:1 shunts the right two posts (pins 2 and 3).</p> <p>All: Check the SAF1 relay. Verify it is properly seated in the socket and does not have any bent pins.</p>	

<b>F112</b>	<b>Closing SAF2</b>	Safety Relay SAF2 Failed to Close
Causes	<p>Rev 5-7 Boards: Jumper J19 on the Cartop SRU board may be in the wrong position.</p> <p>Rev 8+ Boards: Jumper J24:1 on the Cartop SRU board may be in the wrong position.</p> <p>All: The controller is trying to energize (close) safety relay SAF2 but the feedback from the relay shows that it is still de-energized (open). Output 601 on the Cartop SRU board controls the coil of the relay. Input 526 is the normally closed feedback monitor. When 601 is on, 526 should be off. If 526 reports the wrong state for more than 1 second then this fault is logged.</p>	
Remedies	<p>Rev 5-7 Boards: Verify the jumper on J19 shunts the upper two posts (pins 2 and 3).</p> <p>Rev 8+ Boards: Verify the jumper on J24:1 shunts the right two posts (pins 2 and 3).</p> <p>All: Check the SAF1 relay. Verify it is properly seated in the socket and does not have any bent pins.</p>	

<b>F118</b>	<b>Rdn Hall Byp</b>	Primary and Redundant Hall Lock Inputs don't match
Causes	<p>The Hall Lock signals have a primary and a redundant input terminal on the controller. Under normal conditions, the two inputs should change together. If the controller detects a difference on the inputs, a redundancy fault is declared.</p>	
Remedies	<p>Check wiring between Hall Door Bypass switch and Machine Room SRU.</p> <p>Verify that both Hall Door Bypass witch input LEDs transition at the same time when toggling the switch.</p>	

<b>F119</b>	<b>Rdn Car Byp</b>	Primary and Redundant Car Bypass Switch Inputs don't match
Causes	The Car Door Bypass Switch signals have a primary and a redundant input terminal on the controller. Under normal conditions, the two inputs should change together. If the controller detects a difference on the inputs, a redundancy fault is declared.	
Remedies	Check wiring between Car Door Bypass switch and Machine Room SRU. Verify that both Car Door Bypass switch input LEDs transition at the same time when toggling the switch.	
<b>F120</b>	<b>Hall Bypass</b>	Hall Bypass Switch error
Causes	Attempting to bypass locks when car is not on correct mode of Inspection.	
Remedies	If the controller is equipped with Hall Lock Bypass switch, it must be in the off position when not on Cartop or In-Car Inspection.	
<b>F121</b>	<b>Car Bypass</b>	Car Door Bypass Switch error
Causes	Attempting to bypass gate switch when car is not on correct mode of Inspection.	
Remedies	If the controller is equipped with Car Door Bypass switch, it must be in the off position when not on Cartop or In-Car Inspection.	
<b>F122</b>	<b>Low Pressure</b>	Low pressure input is active
Causes	This applies only to hydraulic controllers. The car is not allowed to move if low pressure is detected.	
Remedies	Verify that Low Pressure switch is wired and operating correctly. If Low Pressure switch is not needed, connect a permanent jumper from M24 to Low Pressure input terminal on Machine Room SRU	
<b>F123</b>	<b>Emergency Power</b>	Controller is on emergency power and not selected to run
Causes	The Emergency Power input on the car or group SRU board is active but this car is not selected to run.	
Remedies	Check generator Up to Speed input. If this input is not active no car will be allowed to run. If no Generator Up to Speed contact is present on the generator, jump the Generator Up to Speed input to the Emergency Power input on the controller board. Check that the Emergency Power Selector Switch is set to AUTO or set to this car. Wait for group control board to select this car to run. In a multi-car group, normally only one car is allowed to run at a time under emergency power.	

<b>F124</b>	<b>Slack Gov Rope</b>	Slack Rope input is active
Causes	The controller detected a loss of power on the slack rope input. This would indicate the contact has determine the ropes are slacking	
Remedies	Verify if the ropes are slacking. Verify the input is on.	
<b>F127</b>	<b>Term Limits</b>	The “Bypass Terminal Limits” parameter was left on
Causes	The controller will not allow the car to run on automatic operation if the <i>Bypass Terminal Limits</i> parameter is turned on.	
Remedies	Turn the parameter off by setting MAIN MENU   SETUP   MISC   BYPASS TERM LIMITS = “NO” Check status of the following jumper located on SRU board and set per job specific provided drawings: Rev 5-7 SRU – Jumper J19 Rev 8 SRU – Jumper J24	
<b>F128</b>	<b>Overloaded</b>	Car overload input is active
Causes	The car is on automatic operation and the overload input is indicating that too much weight is in the car.	
Remedies	Remove weight from the car until below rated capacity. Verify that load weighing device is wired and configured correctly.	

<b>F129</b>	<b>RST #2 UN</b>	
Causes	Reset faults other than F130 and F131 may indicate a defective SRU board or mis-programmed software.	
Remedies	For F129, or F132 – F136, contact Smartrise as this may indicate a bad board or software.	

F130	Power-on
Causes	<p>Loss of power to an SRU board will generate an F130 on the J21 and J22 processors.</p> <p>A short circuit on the M24 or C24 bus will cause the power supply to shut off while the short is present. This will result in an F130 fault when the short is corrected.</p> <p>AC power present on the M24 or C24 DC power busses may cause an F130 or F131 fault.</p> <p>Reset faults other than F130 and F131 may indicate a defective SRU board or mis-programmed software.</p>
Remedies	<p>For F130 faults, check power to SRU boards. Verify M24 and C24 busses read 24vdc and that the wires are not loose.</p> <p>For F130 faults reported by CPU A or B, check for a short on the M24 bus. This includes power to the hoistway and hall call stations.</p> <p>For F130 faults reported by CPU C or D, check for a short on the C24 bus. This includes wiring on the cartop and COP stations.</p>



<b>F131</b>	<b>Reset</b>	
Causes	<p>Pressing the reset button on one of the SRU boards will generate an F131 on the J21 and J22 processors.</p> <p>Emergency stop where excessive electrical noise was generated due to arcing when the contactors opened. This will sometimes result in an F131 fault.</p> <p>AC power present on the M24 or C24 DC power busses may cause and F130 or F131 fault.</p> <p>Missing connection from REF in machine room to REF on cartop may cause intermittent F131 faults.</p>	
Remedies	<p>For F131 faults, see if another fault caused an emergency stop that might have caused the contactors to open in flight. This can sometimes cause enough electrical noise to make the board reset.</p> <p>Verify the REF terminal in the machine room is connected to the REF terminal on the cartop.</p> <p>Check for AC voltage on M24 or C24 busses.</p>	

<b>F132</b>	<b>RST #3 SW</b>	
Causes	Reset faults other than F130 and F131 may indicate a defective SRU board or mis-programmed software.	
Remedies	For F129, or F132 – F136, contact Smartrise as this may indicate a bad board or software.	

<b>F133</b>	<b>RST #4 MC</b>	
Causes	Reset faults other than F130 and F131 may indicate a defective SRU board or mis-programmed software.	
Remedies	For F129, or F132 – F136, contact Smartrise as this may indicate a bad board or software.	

<b>F134</b>	<b>RST #5 CO</b>	
Causes	Reset faults other than F130 and F131 may indicate a defective SRU board or mis-programmed software. For F129, or F132 – F136, contact Smartrise as this may indicate a bad board or software.	
Remedies		

<b>F135</b>	<b>RST #6 CP</b>	
Causes	Reset faults other than F130 and F131 may indicate a defective SRU board or mis-programmed software.	
Remedies	For F129, or F132 – F136, contact Smartrise as this may indicate a bad board or software.	

<b>F136</b>	<b>RST #7 W</b>	
Causes	Reset faults other than F130 and F131 may indicate a defective SRU board or mis-programmed software.	
Remedies	For F129, or F132 – F136, contact Smartrise as this may indicate a bad board or software.	
<b>F137</b>	<b>Counterweight</b>	A derailment of the counterweight was detected
Causes	The controller detected a loss of power on the counterweight input.	
Remedies	<p>Do not attempt to run the car if you are uncertain about the status of the counterweight. Until this fault is reset, the car can only be run on Cartop Inspection.</p> <p>Once the counterweight has been confirmed as safe, you can reset this fault with the Earthquake Reset switch. If your controller is not configured for Earthquake Operation then resetting the machine room SRU board with DIP switch 1 on will clear this fault.</p> <p>If this fault occurred erroneously, check the counterweight derailment (“ring and string”) circuit. Verify the grounding ring does not touch the wire at any point as the car moves.</p>	
<b>F138</b>	<b>Construction</b>	Construction input powered without Machine Room Inspection
Causes	The Construction input (MR.523) is powered but the machine room inspection switch is in the “automatic” position.	
Remedies	<p>If you are trying to run the car on Construction mode, turn the machine room inspection switch to the “inspect” position.</p> <p>If you are trying to run the car on standard inspection or automatic, remove the jumper wire from input 523 on the Machine Room SRU board.</p>	
<b>F139</b>	<b>Governor</b>	Speed governor tripped
Causes	The controller detected a loss of power on the governor input. The controller monitors the electrical contact on the governor. This contact will normally open before the mechanical safeties engage.	
Remedies	<p>Check the fault log to see what speed the car was at when the fault was recorded. If the car was over speeding this could indicate a defective drive.</p> <p>Over speeding can also occur if the drive is not properly configured. Try running the car on inspection and verify that the FPM speed feedback tracks the CMD speed. If it does not, check the drive parameters starting with the RPM value of DRIVE A1   CONTRACT MTR SPD.</p> <p>If this fault occurred while the car was stopped or at low speed, it could be a problem with the governor switch or wiring.</p>	

<b>F140</b>	<b>E. Brake</b>	Emergency Brake or Gripper fault
Causes	The Emergency brake or the Gripper has dropped or the Car Top relays are not active.	
Remedies	<p>Manually reset the emergency brake. If the problem persists check the inputs on the Car Top board and Relays: RGM, DZM, RGC, DZC.</p> <p>Perform a Dip1+Reset on the Cartop bd. If that doesn't work then toggle the Cartop Inspection switch on then off.</p>	
<b>F146</b>	<b>Gate Coupling</b>	The gate switch is jumped out or inoperative
Causes	During a door cycle the controller expects the status of the gate switch to change. This fault indicates no change occurred and power was never removed from the GSW inputs during the door cycle.	
Remedies	Check the Cartop board inputs for a jumped or shorted wire.	
<b>F147</b>	<b>Hall Coupling</b>	The hall locks are jumped out
Causes	<p>During a door cycle the controller expects the status of the hall locks to change. The correct sequence is that the Gate Switch is made up first and then the Hall locks are made up.</p> <p>This fault indicates that the switching sequence is opposite or no change occurred and power was never removed from the inputs during the door cycle.</p>	
Remedies	<p>Check the Machine Room board inputs for a jumped or shorted wire.</p> <p>Adjust door cams to activate gate switch before hall interlocks are activated.</p> <p>For troubleshooting purposes, this function may disabled by the detect door jumpers option in door set up. Set this value to "no" if this is the case.</p>	
<b>F148</b>	<b>Brake Pick Switch</b>	Brake Pick Switch failed to close
Causes	The controller is programmed to monitor the mechanical status of the brake.	
Remedies	<p>Check the brake to see if mechanical lift occurs at the appropriate time. Next check to see if the brake inputs are registering appropriately. The most likely cause is the actual brake pick switch on top of the brake. Make sure it's opening and closing fully when the brake activates.</p> <p>Check to make sure that the 24v BPS line from the switch is <u>NOT</u> run in the same conduit with high power lines. It may pick up an induced voltage causing intermittent faults. Run a separate line to isolate from possible inductive voltages.</p> <p>Locate the fault in "MAIN MENU   FAULTS   LOGGED FAULTS" and see if there are any other faults that occurred at the same time and verify that they weren't the cause of the F148: Brake Pick Switch fault.</p>	

<b>F151</b>	<b>Passcode</b>	The passcode required for normal operation is not entered
Causes	The passcode required for normal operation is not entered.	
Remedies	Contact Smartrise for access to the passcode.	

<b>F160</b>	<b>Critical Params</b>	One or more of the “critical” parameters is not valid
Causes	One or more of the following parameters is not set to a valid value: <i>Number of floor</i> <i>Controller type</i> <i>Number of car doors</i> <i>Number of controller boards</i>	
Remedies	After a power-on or board reset, this fault may come on briefly. If the fault clears right away then no action is required.  If the fault persists, you may need to default the parameters by selecting MAIN MENU   SETUP   DEFAULT ALL.	

<b>F161</b>	<b>Invalid Params</b>	One or more of the “critical” parameters is not valid
Causes	<u>Extra Bytes 1-0:</u> No Run Speeds set. <u>Extra Bytes 2-0:</u> Non-ascending Run Speeds. <u>Extra Bytes 3-0:</u> One or more of the Run Speeds is set to a value greater than 900 fpm. <u>Extra Bytes 4-0:</u> Inspection Speed set greater than 150 fpm. To comply with A17.1 code, inspection speeds above 150 fpm are not allowed. <u>Extra Bytes 5-0:</u> Unused Run Speeds not set to zero.	
Remedies	<u>Extra Bytes 1-0:</u> There are eight available Run Speeds (S1-S8). You must set at least one with a non-zero value. <u>Extra Bytes 2-0:</u> The speed defined by S2 must be larger than S1. Likewise S3 must be larger than S2. This applies to all non-zero Run Speeds. All unused Run Speeds must be set to zero. Example: S1 = 50 fpm S2 = 175 fpm S3 = 300 fpm S4 ~ S8 = 0 <u>Extra Bytes 3-0:</u> Reduce the offending Run Speed to less than 900 fpm or contact Smartrise for software to support higher speeds. <u>Extra Bytes 4-0:</u> Reduce Inspection Speed to 150 fpm or less. <u>Extra Bytes 5-0:</u> Set all Run Speeds above highest one used to zero.	

<b>F200</b>	<b>*Internal Software Error</b>	Internal software error.
Causes	Software has encountered an unexpected problem.	
Remedies	<p>An F200 fault will sometimes occur immediately after saving a parameter. This is due to technical details of how the CPUs update their internal Flash memory. No corrective action is required in this case.</p> <p>If an F200 fault occurs during normal operation, contact Smartrise. Please note the information on the Fault Detail screen including the value of the Extra Bytes.</p>	
<b>F201</b>	<b>Control</b>	Fault detected by the control logic.
Causes	Commands to control the car movement are out of sequence or invalid for the current mode of operation.	
Remedies	Fault detected at start of run. This fault can sometimes be caused by a hall lock not properly making at the start of a run. Fault will automatically clear after 5 seconds. Contact Smartrise if fault occurs excessively.	
<b>F202</b>	<b>DPM</b>	DPM input indicates an open car door.
Causes	<p><u>Extra Bytes: 1-0</u> = Front Door</p> <p><u>Extra Bytes: 2-1</u> = Rear Door</p> <p>The Door Position Monitor (DPM) input for the front (or rear) door is not powered, the car is not in a door zone, and the current operating mode does not allow for running with the car doors open.</p>	
Remedies	<p>Verify that the affected car door is closed.</p> <p>Verify that the DPM signal is flagging correctly. Using the “Car Door” and “Hall Door” data screen (See “CAR DOOR DATA SCREEN” section) verify that the doors are closed and are getting proper signals.</p> <p>Doors Closed = GSW / DCL / DPM</p> <p>Doors Open = DOL</p> <p>Verify that the door zone sensor and magnets are working.</p>	
<b>F203</b>	<b>Test Condition1</b>	
Causes	The internal drive speed command holds an invalid value.	
Remedies	Contact Smartrise	

<b>F204</b>	<b>Fire Stop Sw</b>	The Fire Stop Switch is in the STOP position
Causes	The Fire Stop Switch is currently in the STOP position. The controller is configured with a Fire Stop Switch but the car does not have one.	
Remedies	Turn the Fire Stop Switch to the RUN position. If code does not require a Fire Stop Switch you can disable it. Find out which SRU board is configured to receive the Fire Stop Switch. On that board, navigate to MAIN MENU   SETUP   LOCAL INPUTS and set the input that is currently programmed for the Fire Stop Switch to “unused”.	

<b>F205</b>	<b>Need to Learn</b>	Controller needs to learn the hoistway
Causes	The positions of the door zone magnets and/or ETS switches that are stored in the controller’s memory are invalid. You can view the learned positions of the magnets under MAIN MENU   STATUS   MAGNETS. The ETS switches are viewable under MAIN MENU   STATUS   SWITCHES.	
Remedies	Put the controller in LEARN mode and relearn the hoistway.	

<b>F206</b>	<b>Brake w/o Drive</b>	Brake lifted without drive run flag set
Causes	The safety logic has detected that the brake pick or hold command is active without a run command being sent to the drive.	
Remedies	Contact Smartrise.	

<b>F207</b>	<b>Door Close Fail</b>	Car door failed to close
Causes	Controller attempted to close the car doors but did not achieve full closure within the timeout period. Controller detected 5 consecutive failures to nudge close the car doors.	
Remedies	Check doors for physical obstructions that might prevent doors from closing. Use fault log data to determine if door is failing to close at a specific floor or if it is happening at multiple floors. Verify that Gate Switch (GSW) and Door Position Monitor (DPM) inputs come on when doors close. Verify the Door Close Limit (DCL) input goes off when doors fully close. Verify that the time it takes for the doors to close normally is less than the timeout specified by MAIN MENU   SETUP   DOOR SETUP   DOOR TIMEOUT CLOSE. Verify that the time it takes for the doors to nudge closed is less than the timeout specified by MAIN MENU   SETUP   DOOR SETUP   DOOR TIMEOUT NUDGE.	

<b>F208</b>	<b>Door Open Fail</b>	Car door failed to open
Causes	Controller detected 5 consecutive failures to open the car doors.	
Remedies	Verify the Door Open Limit (DOL) input goes off when doors fully open. Verify that the time it takes for the doors to open is less than the timeout specified by MAIN MENU   SETUP   DOOR SETUP   DOOR TIMEOUT OPEN.	
<b>F209</b>	<b>Can't Run Up</b>	Pump motor not coming on in up direction
Causes	Caused by any fault that prevents a hydraulic controller from running the pump motor. This fault will be accompanied by an alarm code specifying one of the following problems: Low Oil Input Motor Thermostat Motor Limit Timeout Battery Lowering	
Remedies	Check the status of inputs for Low Oil, Thermostat, and Battery Lowering.	
<b>F213</b>	<b>Rnd Swing Close</b>	
Causes	Obsolete. No longer logged.	
Remedies	N/A	
<b>F214</b>	<b>Drv Enb Relay</b>	
Causes	The M contactor is energized and the Drive Ready relay is not or vice versa.	
Remedies	Check for drive faults. Check for safety string open.	
<b>F215</b>	<b>CPLD Comm</b>	
Causes	CPLD communication error.	
Remedies	Check PN1, PN2, PN3 wiring from Machine Room to Car Top. Replace SRU Board.	
<b>F216</b>	<b>Ebrake Feedbk</b>	
Causes	Extra Bytes: X-X-{fault code}-0 Feedback from RGM and DZM relays indicate one or both is in the wrong state. 1 = RGM (off) and DZM (off) 2 = RGM (on) and DZM (off) 3 = RGM (off) and DZM (on)	

Remedies	Check the machine room relays flagged in the extra bytes for proper operation. Replace as needed.	
<b>F217</b>	<b>Rnd Governor</b>	
Causes	Obsolete. No longer logged.	
Remedies	N/A	
<b>F218</b>	<b>Safety String</b>	Safety String is open
Causes	Relay SS is de-energized because the safety string has lost power.	
Remedies	Verify that all stop switches, final limits, and other contacts in the safety string (see job specific drawings) are in the closed position.	
<b>F219</b>	<b>Flood Sensor</b>	
Causes	The elevator has been taken out of service at an upper floor due to flooding.	
Remedies	Verify that flood sensor is operating and wired correctly. If Flood Sensor is not required, place a permanent jumper from M24 to Flood Sensor input terminal on Machine Room SRU.	
<b>F220</b>	<b>UET and DET</b>	Both UET and DET are active
Causes	Both ETS switches are in the active state.	
Remedies	Check the switches and controller input terminals. Check the CAT5 cable connections between the IP8300 selector and the breakout board.	
<b>F221</b>	<b>Redundancy</b>	
Causes	This error is normally caused by the jumpers (J24) or Dip Switch settings being set wrong.	
Remedies	Check the Jumpers and Switches on each board and verify correct settings with the drawings specific to that board.	
<b>F222</b>	<b>Relay Feedback</b>	
Causes	The software and the safety hardware circuit are not seeing the same feedback from one of the safety	
Remedies	The first of the two extra bytes shows the SRU input terminal (1=501, 2=502, etc.) monitoring.	



<b>F223</b>	<b>Rnd CT</b>	
Causes	One of the safety input pairs on the Cartop SRU board is showing power on one input and no power on the other. Safety inputs should always go on and off together. The Extra Bytes indicate which terminals are mismatched. For example, if the Extra Bytes are 1-2 then check inputs 501 and 502 on the Cartop SRU board.	
Remedies	Measure the voltage on the terminals to verify the mismatch. If both terminals show the same voltage, the problem may be internal to the board in which case it should be replaced.  Verify wiring is secure in both terminals.	
<b>F224</b>	<b>Lock w/o Closed</b>	
Causes	The controller is configured with separate hall door signals for "doors closed" and "doors locked" (e.g. swing doors). The controller has detected that the doors are showing as locked but not closed. Check for wiring errors or jumpers on the lock inputs.	
Remedies	Add the value 501 to the Extra Bytes to determine the MR SRU inputs that detected the problem. For example if the Extra Bytes are 2 and 27 the check terminals 503 and 528.	
<b>F225</b>	<b>SFH</b>	
Causes	The safety hardware circuitry has detected a fault. Normally, another fault will be logged at the same time.  There is too much noise on the PN1/PN2/PN3 wires from the machine room SRU to the Cartop SRU.	
Remedies	If this fault occurs by itself, check setting of DIP switch bank B on both the Machine Room and Cartop SRU boards.  Also verify traveler wires PN1, PN2, and PN3 are properly connected at both the car and machine room.  Note the Extra Bytes and contact Smartrise if fault persists.	
<b>F226</b>	<b>Overspeed I/L</b>	
Causes	Car exceeded allowed speed for Inspection or leveling with doors open.	
Remedies	Maximum speed for inspection is 150 FPM or 110% of programmed leveling speed (whichever is lower).  Maximum speed for leveling with doors open is 20 FPM or 150% of programmed leveling speed (whichever is lower).	

<b>F227</b>	<b>Preflight Check</b>	
Causes	The system runs a preflight check of all safety connections/relays prior to car leaving a landing	
Remedies	Look at fault log and see if there are any other faults with this one. Follow that fault's remedy. If no other faults exist contact Smartrise technical support.	

<b>F228</b>	<b>E24 Input High</b>	
Causes	During a preflight / post flight check an E24 input did not change state to low. Example: B-M-1-5 is Input 505 on MR board (#1) / B-M-2-14 = Input 514 on CT board (#2)	
Remedies	Verify faulty input looking at fault log and recording the extra bytes. Troubleshoot by swapping responsible relay with known good one or check wiring to/from terminal on board.  Check MAIN MENU   STATUS   I/O   INPUT GROUPS   [GROUP] for viewing the proper changing of state when power is applied or removed from input. When LED is ON the input will have an [X] and when the LED is OFF the input will be inactive [ ].	

<b>F229</b>	<b>NTS Overspeed</b>	
Causes	Car failed to slow normally as it approached a terminal and performed an NTS stop.	
Remedies	If physical NTS switches are being used, they may be too far away from the terminal. Otherwise, try increasing the Normal slowdown parameter in the direction the car was traveling when the fault occurred.	

<b>F230</b>	<b>Rdn MR Input</b>	
Causes	One of the safety input pairs on the Machine Room SRU board is showing power on one input and no power on the other. Safety inputs should always go on and off together. The Extra Bytes indicate which terminals are mismatched. For example, if the Extra Bytes are 1-2 then check inputs 501 and 502 on the Machine Room SRU board. NOTE: Extra Byte 254 = Hall Door Bypass IOs; Extra Byte 255 = Car Door Bypass IOs	
Remedies	Measure the voltage on the terminals to verify the mismatch. If both terminals show the same voltage, the problem may be internal to the board in which case it should be replaced. Verify wiring is secure in both terminals.	

<b>F231</b>	<b>UNTS and DNTS</b>	
Causes	This can happen if the NTS switch inputs are not wired or the incorrect number of switches is specified in parameter 13-176.	
Remedies	Make sure that the NTS switches are wired in and going to correct terminals. Verify that the number of switches in parameter 13-176 is set correctly for your specific job (x01 = UT1/DT1, x02 = UT2/DT2, etc).	
<b>F232</b>	<b>Missed Door Zone</b>	The fault records two extra bytes of information. The first extra byte is the floor the car was trying to go to (0 = bottom landing, 1 = 2 <sup>nd</sup> landing, etc.) and the second extra byte is the floor the car was at when this fault occurred.
Causes	The fault occurs when the car has been leveling for more than 15 seconds and has not seen the destination door zone magnet. After the fault is asserted, the controller will attempt to send the car on a correction run to an available floor.	
Remedies	This fault can indicate a bad or missing door zone magnet or it can indicate a bad door zone sensor. If this fault occurs often and the first extra byte is always the same, it probably means there is a bad or missing door zone magnet at that floor. If the first extra byte changes from one F232 to another, it probably means the door zone sensor is bad.	

<b>F233</b>	<b>Position Sys</b>	The CEDES APS landing system is in a fault condition
<b>Causes</b>	<p>Extra Byte 1:</p> <p>1: <u>Comm loss</u> – CT SRU is not receiving data from Cedes Interface Board (CIB).</p> <p>Extra Byte 2: CEDES fault number:</p> <p>0: <u>No fault</u></p> <p>1: <u>Invalid NTS Data</u></p> <p>2: <u>No Comm</u> – The CIB is receiving bad or no data from the CT SRU.</p> <p>3: <u>No Comm B to A</u> – The A processor on the CIB isn't communicating with the B processor on the CIB.</p> <p>4: <u>No Comm A to B</u> – The B processor on the Cedes Interface Board isn't communicating with the A processor on the CIB.</p> <p>5: <u>No Comm APS A</u> – The A processor on the CIB is not receiving data from the Cedes landing system.</p> <p>6: <u>No Comm APS B</u> – The B processor on the Cedes Interface Board is not receiving data from the Cedes landing system.</p> <p>7: <u>Position mismatch A with B</u> – The two cameras in the Cedes landing system are reporting substantially different positions.</p> <p>8: <u>APS Error A</u> – Tape alignment error being reported by Camera A of the Cedes landing system.</p> <p>9: <u>APS Error B</u> – Tape alignment error being reported by Camera B of the Cedes landing system.</p>	
<b>Remedies</b>	<p>Extra Byte 1:</p> <p>1: <u>Comm loss</u> - Replace Cedes Interface Board (CIB). Replace CT SRU.</p> <p>Extra Byte 2: CEDES fault number:</p> <p>0: <u>No fault</u></p> <p>1: <u>Invalid NTS Data</u> – Need to do NTS learn run(s).</p> <p>2: <u>No Comm</u> – Check CAT5. Replace Cedes Interface Board (CIB). Replace CT SRU.</p> <p>3: <u>No Comm B to A</u> – Replace CIB.</p> <p>4: <u>No Comm A to B</u> – Replace CIB.</p> <p>5: <u>No Comm APS A</u> – Check CAT5. Replace APS. Replace CIB.</p> <p>6: <u>No Comm APS B</u> – Check CAT5. Replace APS. Replace CIB.</p> <p>7: <u>Position mismatch A with B</u> – Check tape for bad alignment or damage. Replace the Cedes APS.</p> <p>8: <u>APS Error A</u> – Check tape for bad alignment or damage. Replace the Cedes APS.</p> <p>9: <u>APS Error B</u> – Check tape for bad alignment or damage. Replace the Cedes APS.</p>	
<b>F234</b>	<b>Set NTS</b>	Set up virtual Normal Terminal Slowdown (150 FPM speed or slower)
<b>Causes</b>	The NTS Values in the setup menu as not been inputted	
<b>Remedies</b>	<p>This is required to be inputted after the learning the hoistway.</p> <p>Set the position of the virtual NTS switches under SETUP   NTS SETUP. NTS positions must be above the bottom door zone and below the top door zone. UNTS must be a larger value than DNTS.</p> <p>This fault only applies to cars that are 150 FPM or slower.</p> <p>This fault only applies to jobs using APS.</p>	

<b>F235</b>	<b>Set ETS</b>	Set up virtual Emergency Terminal Slowdown (Traction only)
<b>Causes</b>	The ETS Values in the setup menu as not been inputted	
<b>Remedies</b>	<p>This is required to be inputted after the learning the hoistway.</p> <p>Set the position of the virtual ETS switches under SETUP   ETS SETUP. ETS positions must be above the bottom door zone and below the top door zone. UETS must be a larger value than DETS.</p> <p>This fault only applies to tractions.</p> <p>This fault only applies to jobs using APS.</p>	

<b>F236</b>	<b>Set TSRD</b>	Set up virtual Terminal Slowdown Reducing Device (Hydro only)
<b>Causes</b>	The TSRD Values in the setup menu as not been inputted	
<b>Remedies</b>	<p>This is required to be inputted after the learning the hoistway.</p> <p>Set the position of the virtual TSRD switch under SETUP   TSRD SETUP. The TSRD position must be below the top door zone.</p> <p>This fault only applies to hydros.</p> <p>This fault only applies to jobs using APS.</p>	

<b>F240</b>	<b>CHK TSRD VALS</b>	Check TSRD Values
<b>Causes</b>	The TSRD Values in the setup menu as not been inputted correctly.	
<b>Remedies</b>	<p>Set the position of the virtual TSRD switch under SETUP   TSRD SETUP. The TSRD position must be below the top door zone.</p> <p>To verify, please check the position of the door zone magnet for the top floor and verify that the TSRD is below it. You can do this by going to MAIN MENU   STATUS   MAGNETS</p> <p>This fault only applies to hydros.</p> <p>This fault only applies to jobs using APS.</p>	

<b>F241</b>	<b>TSRD Overspeed</b>	Overspeed of Car at the TSRD switch (Hydro Only)
<b>Causes</b>	Elevator has passed the TSRD position going up and is at 80% or more of contract speed.	
<b>Remedies</b>	<p>Either move the TSRD position closer to the top landing under the TSRD setup menu or increase the S1 slowdown distance to make the car drop out of high speed earlier.</p> <p>This fault only applies to jobs using APS.</p>	

<b>F250</b>	<b>Brake Board Flt</b>	Main Brake Board / Emergency Brake Board is faulted
<b>Causes</b>	<p>Extra bytes - 8-8: Main brake board fault output is active.</p> <p>Extra bytes - 9-9: Emergency brake board fault output is active.</p> <p>Brake board is asserting a fault. One such fault is that too much current is being drawn by the brake coil. Other fault is if the brake board is detecting a short.</p>	
<b>Remedies</b>	<p>Measure the current of the brake coil to see the amount of current to see if it is going over the rated 5 Amp brake board or 10 Amp Brake Board</p>	

# ALARM DESCRIPTION INDEX

Note: Alarms provide information to the user but do not cause an emergency stop.

<b>A9</b>	<b>At Bottom Term</b>	
Causes	At Bottom Terminal	
Remedies	A command to move the car to the bottom of the hoistway was given but the car is already there.	
<b>A10</b>	<b>At Top Term</b>	
Causes	At Top Terminal	
Remedies	A command to move the car to the top of the hoistway was given but the car is already there.	
<b>A17</b>	<b>Door F Stalled</b>	
Causes	Front Doors are Stalled	
Remedies	The controller was unable to open or close the doors after repeated attempts. Doors are now in a partially opened state.	
<b>A18</b>	<b>Nudging F Door</b>	
Causes	Nudging front doors	
Remedies	The front doors are currently being nudged closed.	
<b>A22</b>	<b>Releveling</b>	
Causes	The Car was in a relevel condition	
Remedies	The floor level may be set improperly. Check the re-level threshold - a count of 001 may be too small and may induce re-levels	
<b>A37</b>	<b>IC Key Required</b>	
Causes	Cartop inspection requires in car inspection active or access	
Remedies	Check in car inspection or access is activated before running the car from cartop	
<b>A38</b>	<b>Battery Lowering</b>	
Causes	Car is being lowered via battery power	
Remedies	Check the battery lowering input. If the input is low when it should be the problem is in the dry contact contained in the device	
<b>A39</b>	<b>Safety String</b>	
Causes	Safety String open	
Remedies	The controller detected an open condition in the Safety String via the SF1 and SF2 relays. Check these relays to ensure they close only when the car is commanded	
<b>A40</b>	<b>Chk Car Door</b>	
Causes	Awaiting Car Doors to Close	
Remedies	Check the gate switch and associated wiring	

<b>A41</b>	<b>Chk Hall Door</b>	
Causes	Awaiting Hall Doors to Close	
Remedies	Check the interlock wiring at the associated landing	
<b>A42</b>	<b>HN/GN Restart</b>	
Causes	Reset in the Hall or Group Network	
Remedies	This may occur during power up or after a manual reset. If it occurs any other time contact Smartrise for assistance	
<b>A43</b>	<b>Overheat</b>	
Causes	Motor Overheat condition	
Remedies	The motor temperature sensor tripped. Check the motor to ensure this condition is not persistent	
<b>A44</b>	<b>Jack Resynch</b>	
Causes	Resynching Jacks	
Remedies	The controller initiated a jack resynchronization.	
<b>A50</b>	<b>MLT</b>	
Causes	Motor ran longer than Max Run Time	
Remedies	<p><u>Traction</u>s: This can be ignored. Reset the controller by cycling to Inspection MR and back to Normal.</p> <p><u>Hydro</u>s: Check to make sure system has proper pressure and oil levels and reset the controller. Make sure that the Contract Car Speed allows the car to travel from terminal-to-terminal in the amount of time set in MAIN MENU   SETUP   TIMERS   MAX RUN TIME.</p> <p>Verify that the viscosity input is not stuck on causing the pump motor to run continuously.</p>	
<b>A51</b>	<b>Low Oil Input</b>	
Causes	Low Oil Input	
Remedies	Check oil level.	
<b>A52</b>	<b>Cold Oil Input</b>	
Causes	Viscosity Input	
Remedies	Check oil level and temperature.	
<b>A53</b>	<b>Seismic</b>	
Causes	Seismic Input	
Remedies	Reset the seismic unit.	
<b>A54</b>	<b>OOS Input</b>	
Causes	Out of Service Input. This is used for a variety of functions.	
Remedies	The OOS input is active. Check the item wired to the OOS input to find out what is the cause.	



<b>A55</b>	<b>Auto Dispatch</b>	
Causes	Group or Hall Network Comm Down	
Remedies	Check to see if group is communicating with car on (GN+/-). Check to see if Simplex SRU is communicating with the Hall Network on (HN=/-). Check for loose wiring or missing shield.	
<b>A56</b>	<b>Limited Speed</b>	
Causes	Limit Speed input active	
Remedies	Reset any installed features that are limiting car speed.	
<b>A57</b>	<b>Smoke/Heat Sensor</b>	
Causes	Smoke Active	
Remedies	Reset tripped smoke sensor; check for loose wiring on MR board.	
<b>A58</b>	<b>Lobby Fire Key</b>	
Causes	Lobby Fire Key Active	
Remedies	Alert indicating the Lobby Fire Key is on.	
<b>A59</b>	<b>Remote Fire Key</b>	
Causes	Remote Fire Key Active	
Remedies	Alert indicating Remote Fire Key is on.	
<b>A60</b>	<b>Position Error</b>	
Causes	Car corrected position on DZ magnet	
Remedies	Monitor travel of car at DZ magnet. Check for overspeed at DZ. If you received this error after a software upgrade then go to Main Menu   Debug   Adjust Parameters and change 13-097 from x00 to x04.	
<b>A61</b>	<b>Checking Parameters</b>	
Causes	Normal on startup	
Remedies	No action needed.	
<b>A62</b>	<b>Check DOL</b>	
Causes	Door open signal not made up when expected	
Remedies	Check for loose wire or intermittent switch contacts on DOL sensor.	
<b>A63</b>	<b>Anti Nuisance</b>	
Causes	Max calls for light load, max stops without PHE	
Remedies		
<b>A64</b>	<b>Stop No DZ</b>	
Causes	Stopped outside of door zone	
Remedies	Car has stopped outside of door zone. Check safety string.	

<b>A66</b>	<b>Ind. Service</b>	
Causes	On Independent Service	
Remedies	Alert that car is on Independent Service. Turn off Ind. Srvc.	
<b>A67</b>	<b>CPLD Speed</b>	
Causes	N/A	
Remedies	Contact Smartrise	
<b>A68</b>	<b>Dip Switches B MR</b>	
Causes	MR SRU: There are DIP B dip switches "On" that is conflicting with the software.	
Remedies	Verify that the software version on all SRU boards are identical. Verify that the dip switch settings match sheet 02 of the drawings.	
<b>A69</b>	<b>Dip Switches B CT</b>	
Causes	CT SRU: There are DIP B dip switches "On" that is conflicting with the software.	
Remedies	Verify that the software version on all SRU boards are identical. Verify that the dip switch settings match sheet 08 of the drawings.	
<b>A70</b>	<b>UET and DET</b>	
Causes	Inputs 509/510 (UET) & 511/512 (DET) are both high on the MR SRU.	
Remedies	Check for proper switch orientation (North above South) and placement on tape. UET: 1.5" North above 3" South DET: 3" North above 1.5" South Check for loose wiring on MR inputs	
<b>A71</b>	<b>Flood Sensor</b>	
Causes	The input for the flood sensor is high.	
Remedies	Verify the input is high and correct the flood sensor switch. If the input is low but it's still alarming then the input may be bad and will need to be moved (see Appendix D).	
<b>A72</b>	<b>NTS Overspeed</b>	
Causes	The NTS slowdown was used at a terminal landing	
Remedies	This happens when the NTS slowdown was initiated instead of the Normal slowdown. The Normal slowdown value is smaller than the NTS slowdown. This is normal during NTS testing at terminal landings.	
<b>A73</b>	<b>M/B monitor</b>	
Causes	M/B Contactor is in the wrong state	
Remedies	This happens when the B contactor or M contactor has picked, but the contacts on those contactors failed to changed states along with it.	
<b>A78</b>	<b>Pre Transfer</b>	
Causes	Power has transferred from back up power to normal power.	
Remedies	Emergency Power operation has switched over to normal power.	

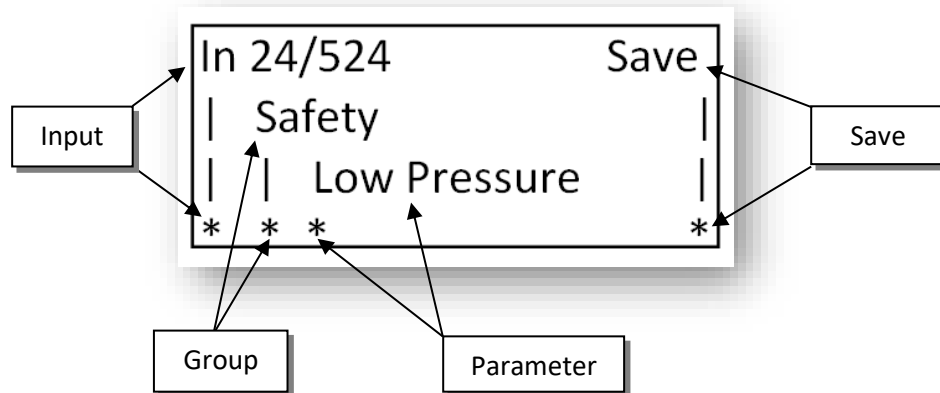
<b>A79</b>	<b>DBR Overheat</b>	
Causes	DBR input is active	
Remedies	The thermal sensors on the DBR has tripped due to heat going over the rating of the DBR. Check the temperature of the DBR.	
<b>A80</b>	<b>NTS Bypassed</b>	
Causes	Learning NTS position on CEDES landing system	
Remedies	This alarm will come up when turning on dip switch 3 along with dip switch 4 or 5, these come up regularly when doing the learn NTS process.	
<b>A99</b>	<b>Long Level</b>	
Causes	Car has been leveling for an excessive amount of time.	
Remedies	The car has been leveling for longer than the threshold, please check slowdown distances.	
<b>A148</b>	<b>Brake Pick Switch</b>	
Causes	The brake pick switch is at a different state than expected	
Remedies	Check for loose wiring, sticking contact or relay for BPS.	

# SRU INPUT / OUTPUT PROGRAMMING TUTORIAL

The Smartrise SRU controller allows the user to program an Input or Output on any unused terminal.

The following example is how an Input is programmed for the addition of a Low Pressure switch on the machine room SRU board:

Example: Programming Instructions for adding an Input for Low Pressure Switch on Input 524



- 1) Go to Main Menu | Setup | Local Inputs
  - a. With asterix on first line "Input" use up/down arrows to scroll to "In 24/524"
  - b. Move asterix over with right arrow to second line (Group) & change to "Safety" using the up/down arrows
  - c. Move asterix over with right arrow to "Parameter" section and change to "Low Pressure" using the up/down arrows
  - d. Move asterix over with right arrow to "Save" line and press "Enter" button to save
- 2) You will need to supply the switch with M24vdc on one side and wire the other to this input port.
- 3) You can perform this for many different types of inputs and outputs. Take some time to scroll through the different categories to see which inputs / outputs are available.

To program an Input you will need to go to Main Menu | Setup | Local Inputs.

To program an Output you will need to go to Main Menu | Setup | Local Outputs.

*Note: Not all controllers will have ALL of these options as they are based on software revisions. This is just a generic reference for determining which category has which input/outputs.*

1. Auto Operation
  - a. (Inputs) Enable All CCBs, Independent Service, Light Load, Enable All HCBs, Door Hold, EMS IC Key, Chime Enable, Sabbath Enable, Attendant Enable, Attendant Up Button, Attendant Down Button, Attendant Bypass Button, Car To Lobby, Swing Operation
  - b. (Outputs) PI 1~8, Hall Lantern Up A~D, Hall Lantern Down A~D, Travelling Up, Travelling Down, Emergency Power, PI 9, In-Car Buzzer, Passing Chime, EMS IC Lamp, Sabbath Lamp, Disable PHE, Attendant Hall Call Above, Attendant Hall Call Below, In Service
2. Doors (Front)
  - a. (Inputs) GSW (1,2), DCL, DOL, PHE, Mechanical SE, DZ, DCB, DOB
  - b. (Outputs) Closer, Open, Nudge, Run/DCP, Hall Lock Cam, Restrictor, Heavy Door, Door Hold Lamp, Car Lantern Up, Car Lantern Down
3. Doors (Rear)
  - a. Same as Doors (Front)
4. Fire/Earthquake
  - a. (Inputs) Smoke 1~4, Phase2 Hold, Phase2 Off, Phase2 On, Call Cancel, Remote Key, Seismic, Counterweight, EQ Reset, Fire Stop Switch, On Emergency Power, EP (Emer Pwr) Up to Speed
  - b. (Outputs) Fire Lamp IC, Fire Lamp Lobby, Earthquake Lamp, Fire Phase I, Fire Phase II, Fire Main, Fire Alt, Shunt Trip, Doors Open @ Lobby
5. Inspect/Access
  - a. (Inputs) Inspection MR Enable (1,2), Inspection MR Up, Inspection MR Down, Inspection CT Enable (1,2), Inspection CT Safe, Inspection CT Up, Inspection CT Down, Access Enable (1,2), Access Bottom Up (1,2), Access Bottom Down (1,2), Access Top Up (1,2), Access Top Down (1,2), Inspection IC Enable (1,2), Inspection IC Safe, Inspection IC Up, Inspection IC Down
  - b. (Outputs) On Inspection
6. Controller
  - a. (Inputs) Brake Pick, Viscosity, Battery Power, B Cont NO (Normally Open), B Cont NO (Normally Open), M Contactor NC, SF1 Relay NC, SF2 Relay NC, DP1, DP2, Pos Ref Switch, Drive Ready, Drive Fault, E-Brake RGM, E-Brake RGP, E-Brake DZM, E-Brake DZP, Limit Speed, Go OOS, Shift Data, Shift Reset, Shift Clock,, SPLD Relay NC, ECO Relay, B2 Cont NO (Normally Open), Drive Enable
  - b. (Outputs) SF1 Relay, SF2 Relay, SM Relay, Relay UPH, Relay UPL, Relay DNH, Relay DNL, Brake Pick, Brake Hold, Drive Fault Reset, Drive Field Enable, Drive Run Up, Drive Run Down, Drive S0~S3, Relay RGM, Relay RGP, Relay DZM, Relay DZP, Fan/Light, Brake Relevel, Drive Run, ECO/NCO Relay, SPLD Relay, S-Curve, Shift Reset, Shift Clock, Shift Data, On Main Line, On Battery, R Relay, S Relay

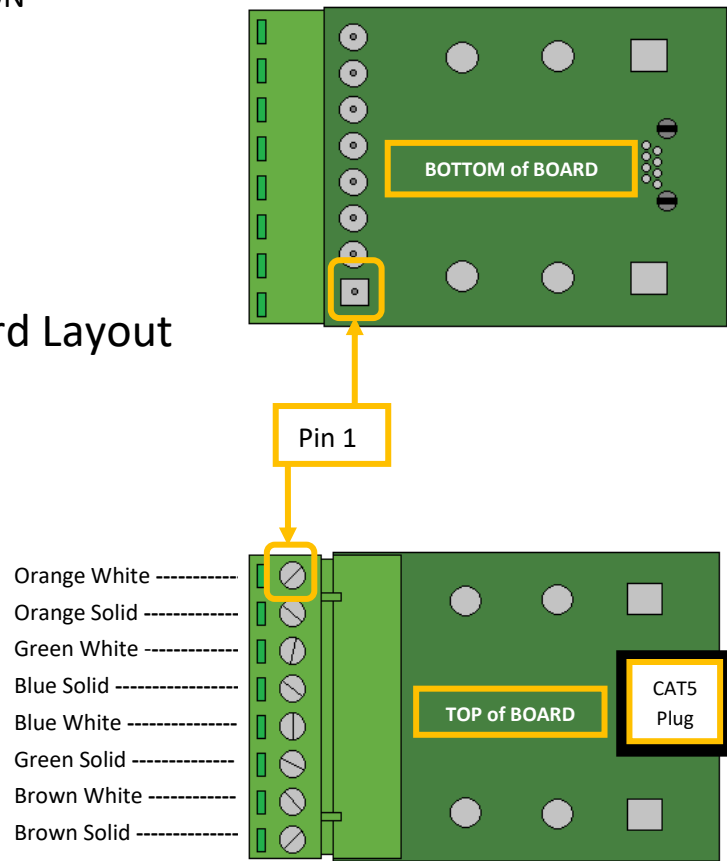
7. Safety
  - a. (Inputs) Locks Top (1,2), Locks Middle (1,2), Locks Bottom (1,2), Hall Closed Top, Hall Closed Middle, Hall Closed Bottom, DET, UET, Construction, Stop Switch IC (1,2), Low Oil, Low Pressure, Overloaded, Fully Loaded, Governor, Overheat, Normal Limit Top, Normal Limit Bottom, Safety String, Flood Sensor, Governor (2)
  - b. (Outputs) Overloaded Lamp, UPH Cutoff, UPL Cutoff, DNH Cutoff, DNL Cutoff
8. Car Call (Front)
  - a. (Inputs) Button 01~64
  - b. (Outputs) Lamp 01~64
9. Car Call Enable (Front)
  - a. (Inputs) Key 01~64
  - b. (Outputs) N/A
10. Car Call (Rear)
  - a. (Inputs) Button 01~64
  - b. (Outputs) Lamp 01~64
11. Car Call Enable (Rear)
  - a. (Inputs) Key 01~64
  - b. (Outputs) N/A
12. Hall Call Up (Front)
  - a. (Inputs) Button 01~32
  - b. (Outputs) Lamp 01~32
13. Hall Call Down (Front)
  - a. (Inputs) Button 01~32
  - b. (Outputs) Lamp 01~32
14. Hall Call Up (Rear)
  - a. (Inputs) Button 01~32
  - b. (Outputs) Lamp 01~32
15. Hall Call Down (Rear)
  - a. (Inputs) Button 01~32
  - b. (Outputs) Lamp 01~32

*NOTE: Certain menu items are “Fixed” and cannot be changed. Contact Smartrise if you suspect a defective input or output terminal that is located on a fixed terminal.*

# APPENDIX A – SMARTRISE BOARDS

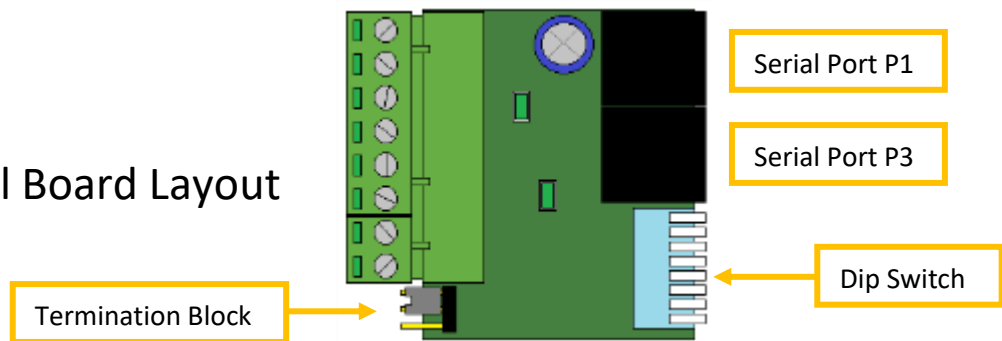
## BREAKOUT BOARD CONFIGURATION

Breakout Board Layout

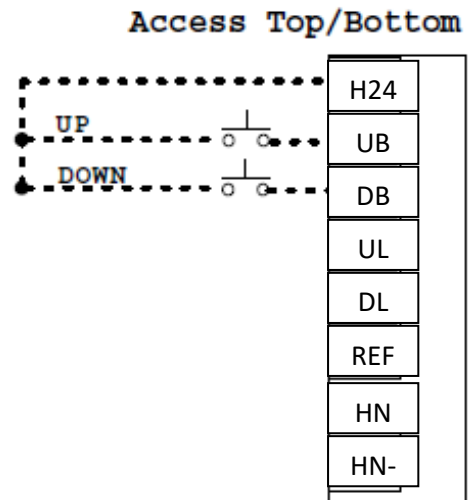
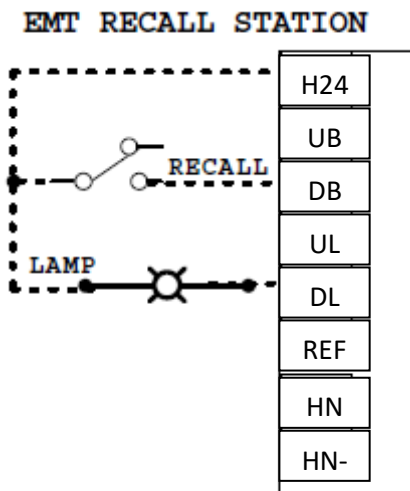
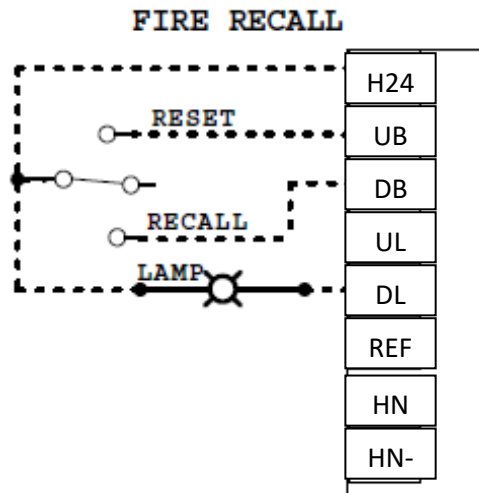
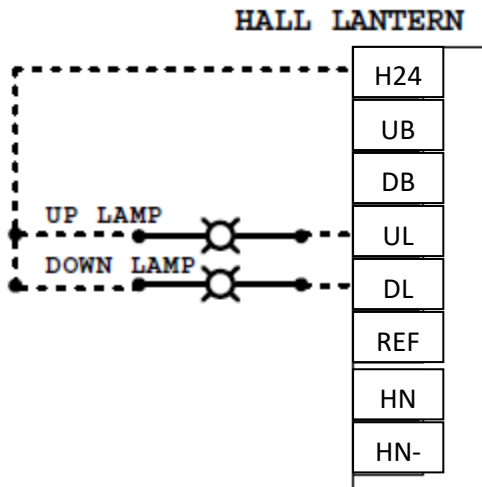
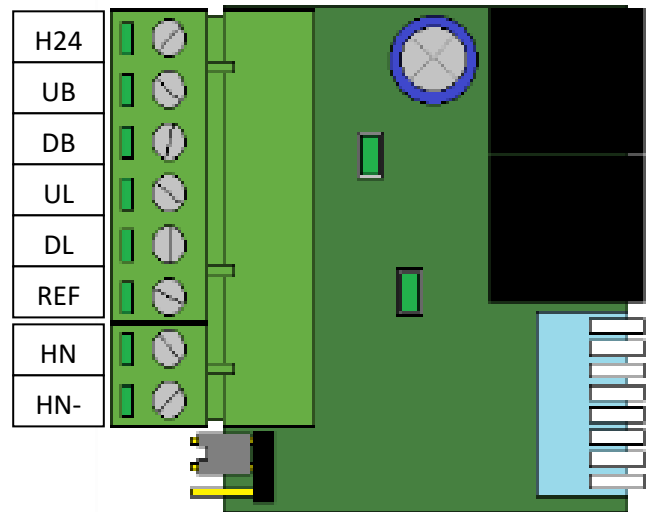
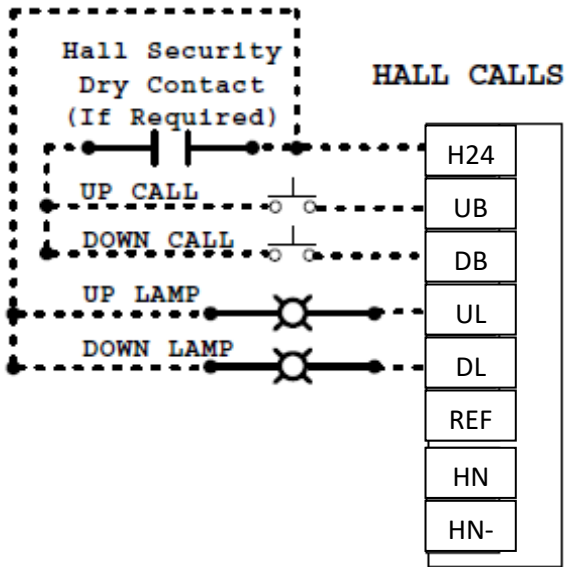


## HALL BOARDS AND CABLING

Hall Board Layout



# HALL NETWORK BOARD CONFIGURATIONS

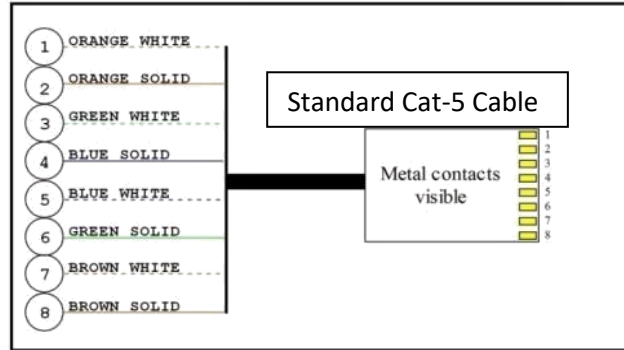




# APPENDIX B – MAKING CAT5 CABLES

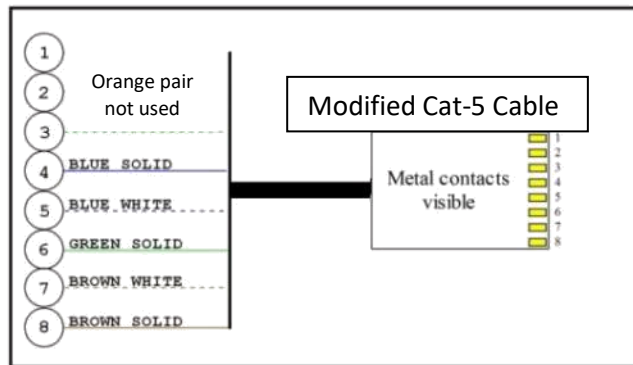
## Standard

The standard CAT5 cables are used for most of the connections. It is used to connect the Hall and Lantern networks toe the MR or Group SRU, the Selector to the IP8300 breakout board and the Inspection station to the inspection breakout board at the Cartop or COP station. You can make your own using this diagram.



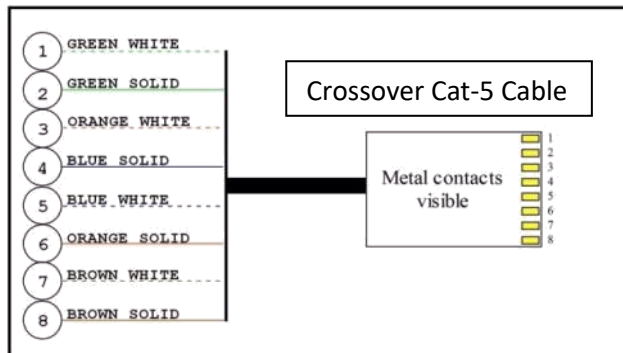
## Modified (CT board to COP board only)

The modified CAT5 cable connects the CT SRU board to the COP SRU in a three board system. This cable has been modified by SM but cutting the Orange pair. You can make your own using this diagram.



## Crossover (COP board to Expansion board only)

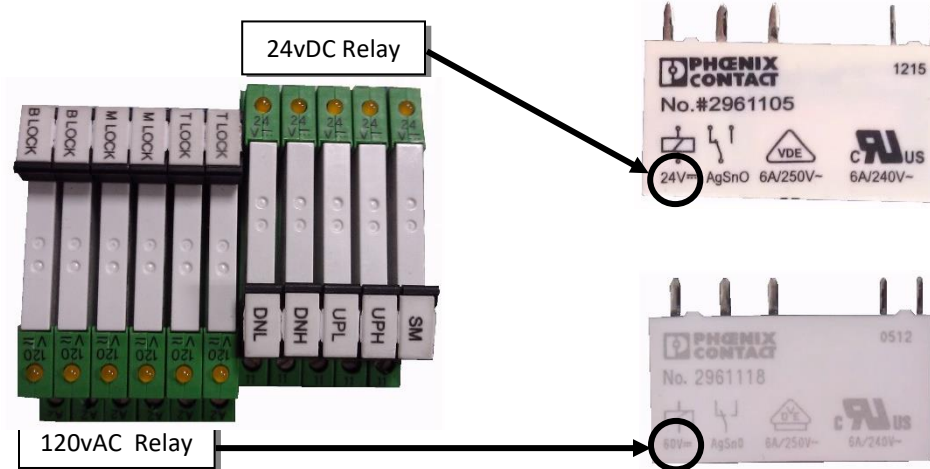
The crossover CAT5 cable is only used when connecting one COP SRU board to a 2<sup>nd</sup> “Expansion” COP SRU board. You can make your own using this diagram. This cable has two pairs cross over from one plug to the other. One side will have the standard T-568B wiring and the other will have the Orange/Green pairs swapped like the following drawing shows.



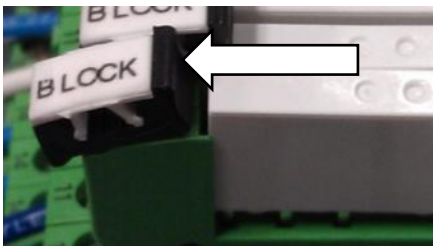
# APPENDIX C – REPLACING RELAYS

## REPLACING SLIMLINE RELAYS

If replacing relays make sure that the new relay you're installing is the same voltage as the old one. Smartrise uses 120vac and 24vdc relays that look similar. See the photos below to determine the different relays.



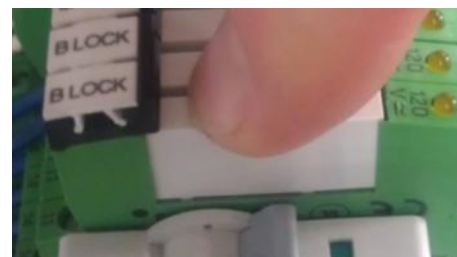
1. To inspect a slimline relay push out on the black tab that contains the label.



2. Pull up on the white relay.



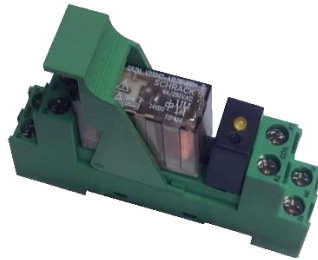
3. Re-install the relay the same way making sure you don't bend any pins when inserting it into the base. Pushing down on the relay will snap the black tab back into the locking position.



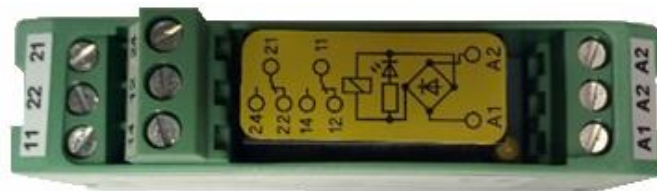
**\*\* NOTE:** If the relay you're replacing is burnt out, has been arcing or is missing a pin, you should replace the whole relay/base assembly. This will eliminate any damage done to the base from the relay terminals.

# REPLACING FORCE GUIDED RELAYS

Smarterise no longer uses the older style force feedback relays with the removable contacts.



The new force guided relay eliminates the possibility of bent pins on the removable relay. Since the contact part of the relay is permanently installed in the base to prevent bent pins from removal, no maintenance is required.

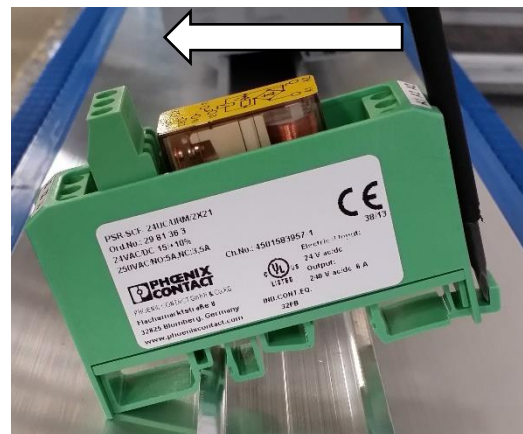


1. If the relay is found to be defective then replace the complete assembly.
  - a. Turn off main power.
  - b. Label the wires and then remove them from old relay.
  - c. To remove the relay from the rail, insert a large flat-blade screwdriver into the tab (figure 1) and pull screwdriver handle back towards the relay (figure 2).
  - d. Install the new relay by attaching the side opposite the tab onto the rail first and then rotating it down onto the rail, snapping it into place.
2. Re-install the wiring to the correct terminals.
3. Restore power.

Figure 1

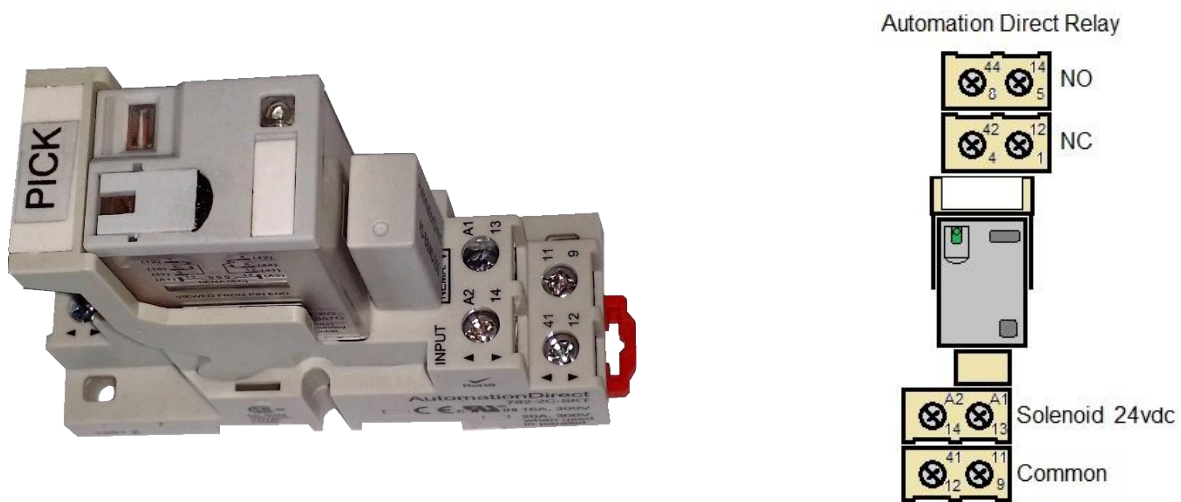


Figure 2



# REPLACING PICK RELAY

Smartrise now uses the Auto-D Pick relay. Use the following diagram for reference when replacing the older style force feedback relay with the new Auto-D relay.



1. If the relay is found to be defective then replace the complete assembly.
  - a. Turn off main power.
  - b. Label the wires and then remove them from old relay.
  - c. To remove the relay from the rail, insert a large flat-blade screwdriver into the red tab (figure 1) and pull screwdriver handle back towards the relay (figure 2).
  - d. Install the new relay by attaching the side opposite the tab onto the rail first and then rotating it down onto the rail, snapping it into place.
2. Re-install the wiring to the correct terminals.
3. Restore power.

Figure 1

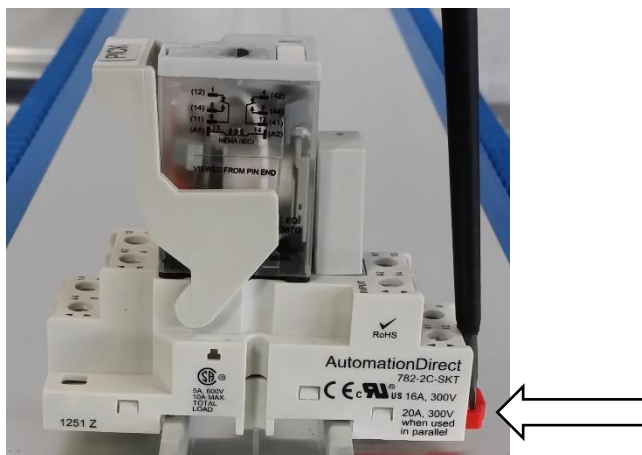
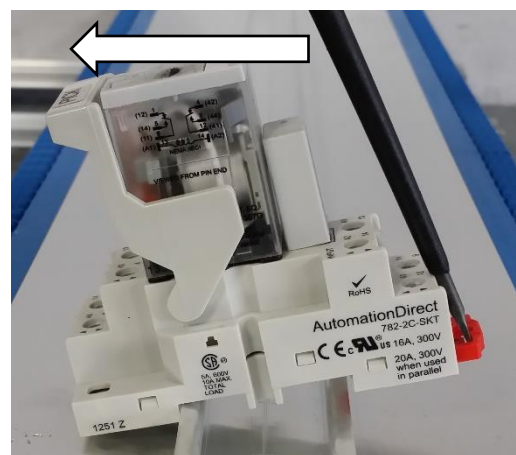


Figure 2



# ADDENDUM I – REPLACING AND PROGRAMMING A DEFECTIVE SRU BOARD

---

Smartrise SRU boards are backwards compatible with prior revisions. Any Rev 8 boards can replace all prior revision boards.

## Tips to Preserve Your Settings during Board Replacement

The Machine Room (MR) board sends all settings and parameters to the Cartop (CT) and Car Operating Panel (COP) boards. These settings are stored in each board. If the Machine Room SRU goes out then the only way to save your jobs settings (Slowdowns, Floor Levels, Parameters, etc.) is to replace it and reprogram it with either the COP board or the CT board. Follow these steps:

1. Replace the MR board with either the CT or COP board
2. Reprogram it as the MR board.

**\*\* DO NOT USE “DIP SWITCH 1” + “DEFAULT ALL” AFTER PROGRAMMING \*\***

3. Install the new board as the CT or COP board and program it as such.

The previous settings in the reprogrammed MR board will then transfer to the new board and the car should operate as before with all the original settings.

You can replace either the CT or COP board at any time as it will retrieve the settings from the MR board when powered up.

## Tools Needed for Programming

To program an SRU board you will need:

- Smartrise Programming Pod
- A fully charged laptop with either of the following operating systems: Windows XP, Vista, 7 or 8.
- The software for your specific job is provided by Smartrise in two ways: a Smartrise CD included in the job binder OR by online download. Contact Smartrise if you don't have the software for your particular jobsite.



# Step 1 - Software Extraction to Laptop

Software provided by online download link

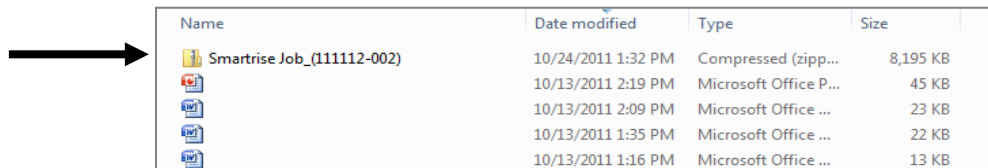
If an update was made to the job OR the CDs are missing, Smartrise can send an e-mail with a link to a downloadable zip file for the software. For example:






[http://smartrise.info/Software\\_packages/Smartrise\\_Job\\_\(111112-001\).zip](http://smartrise.info/Software_packages/Smartrise_Job_(111112-001).zip)

1. Click on the link and choose “Save As” to save the zip file to your laptop, preferably to your desktop.

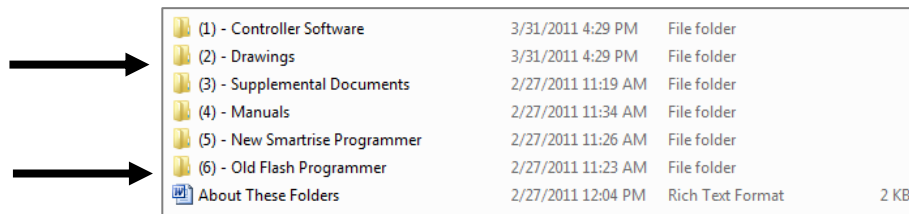
There are several ways to open a zip file. Your laptop should have the capability to extract the file to a location of your choosing. If not you will need to download a free program from the internet to process this file.








2. Navigate to the location you saved the file and double click on it to show the contents.



Name	Date modified	Type	Size
 Smartrise Job_(111112-002)	10/24/2011 1:32 PM	Compressed (zipp...	8,195 KB
 Microsoft Office P...	10/13/2011 2:19 PM	Microsoft Office P...	45 KB
 Microsoft Office ...	10/13/2011 2:09 PM	Microsoft Office ...	23 KB
 Microsoft Office ...	10/13/2011 1:35 PM	Microsoft Office ...	22 KB
 Microsoft Office ...	10/13/2011 1:16 PM	Microsoft Office ...	13 KB

3. Some laptops won't allow the Smartrise programmer to run directly from a zip file. To resolve this you need to copy all the contents of the zip file to a folder on your laptop. This will allow you to access all the folders necessary for installation (i.e. software, Smartrise Programmer, etc).



 (1) - Controller Software	3/31/2011 4:29 PM	File folder	
 (2) - Drawings	3/31/2011 4:29 PM	File folder	
 (3) - Supplemental Documents	2/27/2011 11:19 AM	File folder	
 (4) - Manuals	2/27/2011 11:34 AM	File folder	
 (5) - New Smartrise Programmer	2/27/2011 11:26 AM	File folder	
 (6) - Old Flash Programmer	2/27/2011 11:23 AM	File folder	
 About These Folders	2/27/2011 12:04 PM	Rich Text Format	2 KB

4. Now that the files are extracted to your laptop's hard drive you can proceed with the installation of the programmer (if not installed already) and the software.



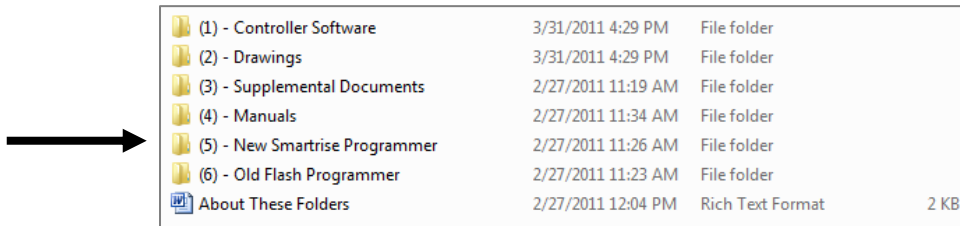
## Step 2 - Installing the Smartrise Programmer

Special considerations need to be made when installing the software:

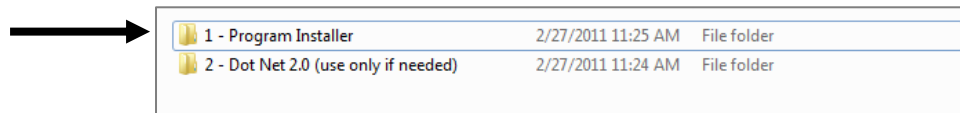
Do you have the Smartrise Programmer Application to install the software?

- If not, install the application by doing the following:

1. Open the (5) New Smartrise Programmer Folder in your software package



2. Open the 1 – Programmer Installer Folder

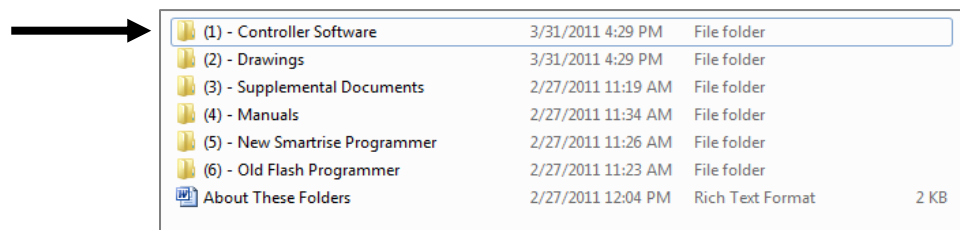


3. Install the Smartrise Programmer

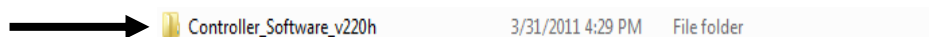


4. Once the Smartrise Programmer is installed go back to the index of folders (shown below) and open the:


(1) Controller Software folder with the JCF Software file inside shown below:



5. Open the Software Folder, in this example the version is 2.20h, the version will vary on how recent the job is.

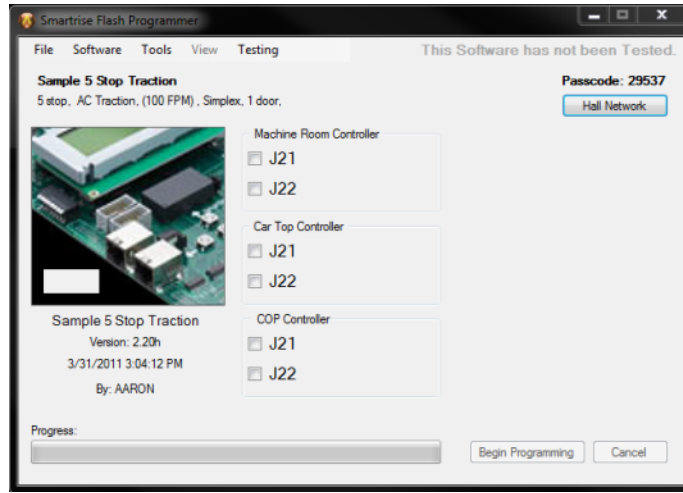


6. Open the JCF file by double clicking on it. If it doesn't open then the Smartrise Programmer might not be correctly installed. Please see previous page for installation instructions.



Sample 5 Stop Traction [ver 2.20h]	3/31/2011 3:04 PM	JCF File	921 KB
postbuild	3/31/2011 3:04 PM	Text Document	1 KB
mrb_j22.hex	3/31/2011 3:03 PM	HEX File	166 KB
mra_j21.hex	3/31/2011 3:02 PM	HEX File	175 KB
IO (Machine Room)	3/31/2011 3:04 PM	Chrome HTML Do...	8 KB
IO (Car-Top)	3/31/2011 3:04 PM	Chrome HTML Do...	8 KB
IO (Car Operating Panel)	3/31/2011 3:04 PM	Chrome HTML Do...	8 KB
ctb_j22.hex	3/31/2011 3:03 PM	HEX File	162 KB
cta_j21.hex	3/31/2011 3:03 PM	HEX File	131 KB
copb_j22.hex	3/31/2011 3:04 PM	HEX File	169 KB
copa_j21.hex	3/31/2011 3:03 PM	HEX File	77 KB
config_1	3/31/2011 3:02 PM	H File	22 KB

### The Smartrise Programmer interface



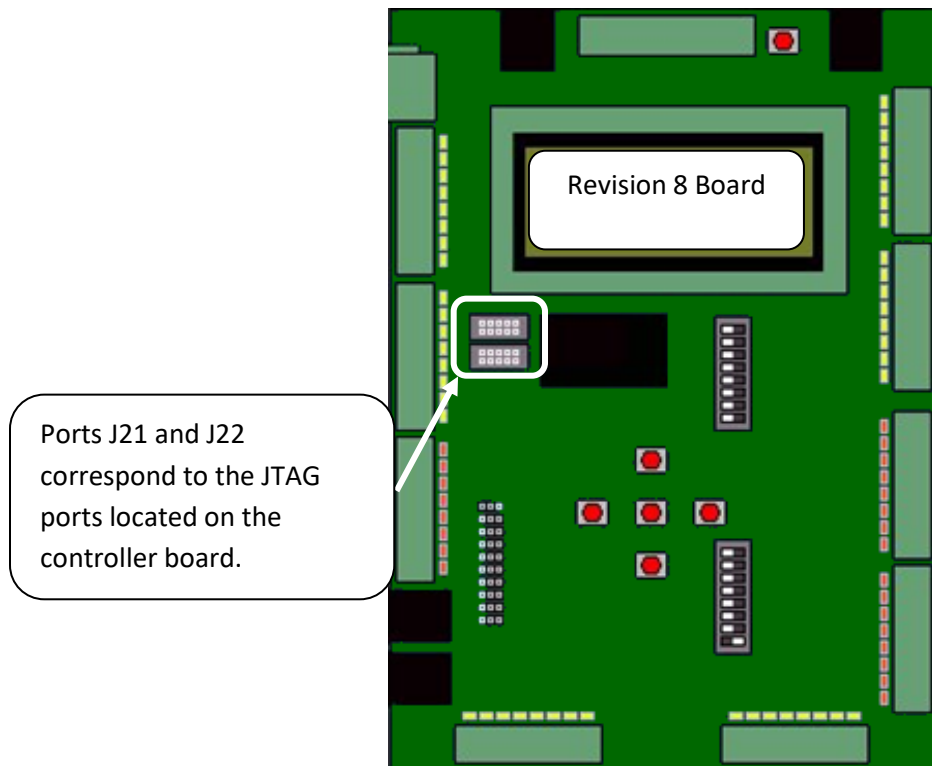
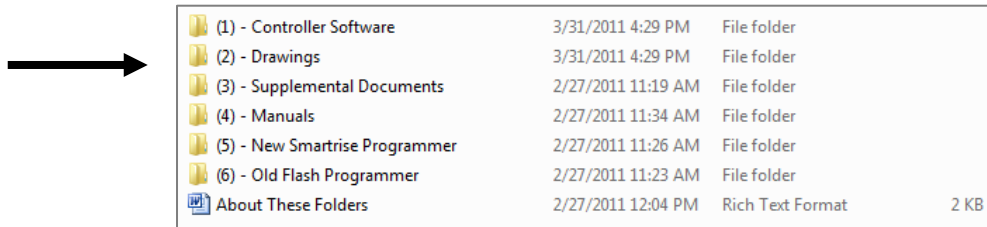
Note: All the controller software is located on this interface except the group software.



## Software provided by USB Flash Drive

Every Smartrise job is provided with a binder that consists of a USB Flash Drive containing software for the specific job. Smartrise controllers are shipped with the software already installed on the controller; this flash drive is provided as a back-up.

1. Insert the supplied USB Flash Drive into the laptop. Usually a menu similar to the one shown below will appear. If no menu appears then open “My Computer” and click on the Removable Disk drive.
2. Click on the “Open folder to view files” option to explore the Smartrise folders. A list of folders with the software will appear. The software is located in the “(1) – Controller Software” folder.



It is imperative that you install the correct software onto the correct JTAG port.

To do this, first connect your Smartrise programmer to your laptop via USB, and then connect the other end to the JTAG port on the controller.

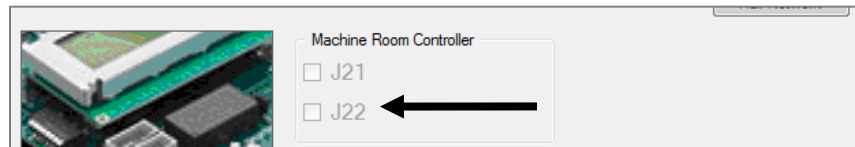
## Step 3 - Installing the SRU Software

Warning: Your laptop needs to be fully charged for this process, plugging in your laptop to an AC source while installing software could result in damage to the SRU Board. Also, do not disconnect the programmer pod from the SRU board while the controller is being programmed.

Identify which controller you are installing, Machine room, Car-Top, COP.

### Instructions for Programming a Machine Room Controller

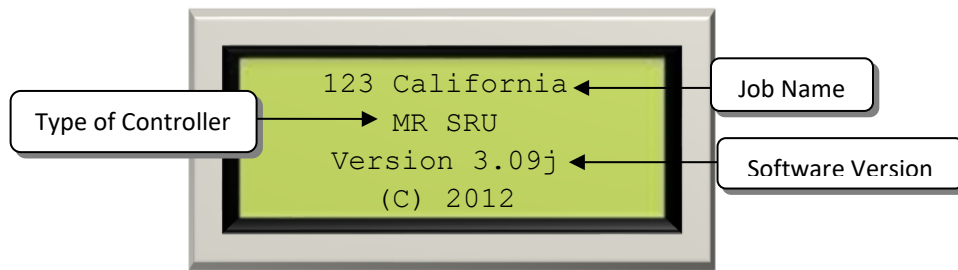
1. A controller cannot be programmed if unpowered, ensure that you have 24V supplied to the controller.
2. When you activate Dip Switch 1 you should see a “F77: CPU Stop Switch” fault on the controller. Do not be alarmed – this is normal.
3. Plug in the programming pod into the J21 port first. Select the J21 checkbox on the Smartrise programming application show below.



4. Next, click the “Begin Programming” button on the bottom of the programming interface to begin programming your board.
5. Notice the progress report bar, when programming is finished, you will see a
  - a. "Progress: Done" when programming is finished.
  - b. NOTE: You will also want to verify that the POWER and RUN LED's on the programming pod itself are off before disconnecting from a controller.
6. Next move your programming pod from port J21 to J22, then click on the J22 check box and begin programming.
7. When programming is finished:

CYCLE POWER – **\*\* DO NOT PRESS THE RESET BUTTON \*\***

8. Next, go to the MAIN MENU | SET UP | DEFAULT ALL | select “Yes” and press the center button. The controller will begin defaulting all the factory parameters to original programming (This could take several minutes). Once this is finished, cycle power again.
9. When the controller is fully powered and finished loading, turn off Dip Switch 1.
10. Verify that the controller is programmed correctly. This is done by going to the MAIN MENU | ABOUT screen. If all the information is correct, the Machine Room Controller has been successfully programmed.



## Instructions for Programming a Car Top/Car Operating Panel Controller

Programming these boards is very similar to programming a machine room controller. When programming these boards it is not necessary to activate dip switch 1 and default all.

- A controller cannot be programmed if unpowered, ensure that there is 24V supplied to the controller.
- Plug in the programming pod into the J21 port first. Select the correct J21 checkbox on the Smartrise programming application for the corresponding controller.
- Next, click the “Begin Programming” button on the bottom of the programming interface to begin programming the board.
- Notice the progress report bar, when programming is finished, the display will show "Progress: Done". NOTE: Verify that the POWER and RUN LED’s on the programming pod itself are off before disconnecting from the controller.
- Next move the programming pod from port J21 to J22, click on the J22 check box and then “Begin Programming”.
- When programming is finished:
 

CYCLE POWER – **\*\* DO NOT PRESS THE RESET BUTTON \*\***
- When the controller is fully powered and finished loading, verify if the controller is programmed correctly by going to the MAIN MENU | ABOUT
- If all the information is correct, the controller software has been successfully installed.

## ADDENDUM II – ENCODER WIRING TABLES

**This is just a partial list of common encoder cable codes for reference only. This may not represent the actual cable you have received with your encoder. Please follow the actual pinout instructions that came with your existing encoder.**

ENCODER	IMPERIAL / PG-X3	MAGIL	ACCUCODER	WACHENDORFF	INDUSTRIAL ENCODER (CANADA)
PWR	RED	RED	BROWN	BROWN	BROWN
COM	BLACK	BLACK	BLUE	WHITE (SHIELD)	WHITE
A	WHITE	WHITE	WHITE	GREEN	GREEN
/A	BLACK/WHITE	BROWN	GREEN	RED	PINK
B	BLUE	GREEN	YELLOW	YELLOW	YELLOW
/B	RED/BLACK	BLUE	GRAY	BLACK	BLUE
Z	ORANGE	YELLOW	PINK	GRAY	GRAY
/Z	GREEN	ORANGE	RED	VIOLET	RED
DATA	-	-	-	-	-
/DATA	-	-	-	-	-
CLOCK	-	-	-	-	-
/CLOCK	-	-	-	-	-
SHIELD	SHIELD	SHIELD	SHIELD	SHIELD	

ENCODER	HEIDENHAIN	ZEIHL	TORIN ECN413	IH740 / IH950
PWR	GREEN/BLUE + BROWN	GRAY/GREEN	RED/PINK	BROWN (2)
COM	GREEN/WHITE + WHITE	PINK/YELLOW	BLACK + RED/WHITE	WHITE (1)
A	GREEN/BLACK	GRAY/PINK	GREEN + BLACK	GREEN (3)
/A	YELLOW/BLACK	RED/BLUE	YELLOW + BLACK	PINK (6)
B	BLUE/BLACK	BLUE	BLUE + BLACK	YELLOW (4)
/B	RED/BLACK	RED	RED + BLACK	BLUE (7)
Z	-	-	-	GRAY (5)
/Z	-	-	-	RED (8)
DATA	GRAY	WHITE	GRAY	-
/DATA	PINK	BROWN	SILVER	-
CLOCK	VIOLET	VIOLET	PURPLE	-
/CLOCK	YELLOW	BLACK	WHITE	-
SHIELD				

## ADDENDUM III – TRACTION BRAKE PICK OPERATION

---

NOTE: In order for the brakes to work when the main line disconnect is turned off the auxiliary switch mounted on the disconnect box must be wired to ML1 / ML2.

1. Switch the main line disconnect to the off position.
2. Turn on Dip switch #6 on Dip A and set the Machine Room inspection switch to inspection.  
*This keeps the controller from trying to run the car and prevents faults from popping up.*
3. Turn the Battery Rescue Switch to the ON position.
4. This should power up the SRU board and provide power for the brake coil(s) to pick.
  - a. The following faults can be ignored during this procedure:
    - i. Stopped no DZ
    - ii. Drive Fault
5. On the SRU LCD screen, record the location (feet/inches) of the car in the hoistway. Check to see if there is a “DZ” in the upper right hand corner of the LCD screen. If “DZ” is present the car is already in a door zone. If the car is in a door zone skip to Step 9.
6. Navigate to Main Menu | Status | Magnets and scroll to the nearest floor above and below the car to see which floors the car is between. This will tell you where you need to move the car to for a door zone.
7. Press the button on the box labeled Brake Pick while simultaneously pressing in the Contactors B1 (and B2 if installed). This should lift the brake(s) and allow the car to drift.
8. Allow the car to drift until a Door Zone is reached.
  - a. The SRU board has an indicator in the top right of the controller labeled DZ.
  - b. This indicator activates if the car is +/-3 inches away from floor level at any landing.
  - c. At this point a B+\_\_ (car moving up) or T-\_\_ (car moving down) number will appear on the line below DZ.
  - d. Depending on the magnet placement, if the B+ or T- number reads 14 the car should be close to floor center.
  - e. Release the B1 & B2 contactors.
9. At this point from the SRU board.
  - a. Using the Right Arrow key navigate to Main Menu | Setup | Door Setup | Manually Open and Close.
  - b. Use the Right and Left Arrow buttons to put the asterisk under Open.
  - c. Press and hold the Enter button to open the doors. Once the Indicator indicates the doors are fully open. Release the Enter button.
  - d. Once Passengers have disembarked. Move the Asterisk under Nudge. Press and hold the Enter button until the doors show fully closed.
10. Turn off the switch in the remote box labeled Brake Pick.
11. When safe to do so power on the Main Line Disconnect.

# ADDENDUM IV – PARAMETER ADJUSTMENTS

## Binary Parameters

To turn on the options below, go to the MAIN MENU | DEBUG | BINARY PARAMETERS menu and set any of the following parameters.

Parameter:	OFF	ON
<b>Fire Options:</b>		
00-081.4	Smoke 1 to open front door.	Smoke 1 to open rear door.
00-081.5	Smoke 2 to open front door.	Smoke 2 to open rear door.
00-081.6	Smoke 3 to open front door.	Smoke 3 to open rear door.
00-081.7	Smoke 4 to open front door.	Smoke 4 to open rear door.
00-088.5	Fault on Locks Jumped on Fire Phase 2	Bypass Locks Jumped Fault on Fire Phase 2
00-088.6	Main or Remote fire key to override smokes.	Main <u>and</u> Remote Fire key to Override Smokes
00-088.7	Disable Remote Fire Key	Enable Remote Fire Key
00-106.0	Constant pressure Door Close button	Phase 2 Door Close Button Momentary
00-106.2	Don't Auto-Open at Recall Level	Phase 2 Auto-Open at Recall Level
00-106.7	Lobby Fire Lamp does not flash.	Flash Fire Lobby Lamp when car lamp flashes (Simplex only)
<b>Fire Code:</b>		
00-018.0	New York Fire Code	ANSI Fire Code
00-018.1	New York Fire Code	ANSI Fire Code
00-018.2	N/A	ANSI Fire Code / New York Fire Code
00-018.3	N/A	ANSI Fire Code / New York Fire Code
00-018.4	New York Fire Code	ANSI Fire Code
00-018.5	New York Fire Code	ANSI Fire Code
00-018.6	New York Fire Code	ANSI Fire Code
00-018.7	New York Fire Code	ANSI Fire Code
00-088.5	ANSI Fire Code	New York Fire Code
00-106.3	ANSI Fire Code	New York Fire Code
00-106.6	ANSI Fire Code	New York Fire Code
<b>EMS:</b>		
13-014.0	Disable EMS/Code Blue	Enable EMS/Code Blue medical Service
13-014.1	EMT Medical Service	Code Blue medical Service
13-014.2	Phase 1 before Phase 2 Medical	Phase 2 Medical without Phase 1

Parameter:	OFF	ON
<b>Doors:</b>		
00-109.7	Separate Front and rear arrival lanterns	Combine arrival lanterns on front lanterns
00-109.5	Single chime output on down arrival	Double chime output on down arrival
13-120.2	Open front door on Battery lowering walk through	Open rear door on Battery lowering walk through
<b>Invert Signals:</b>		
13-099.0	Low Oil Normally Closed	Low Oil Normally Open
13-099.1	Low Pressure Normally Closed	Low Pressure Normally Open
13-099.2	Door Close Limit Normally Closed	Door Close Limit Normally Open
13-099.3	Door open Limit Normally Closed	Door open Limit Normally Open
13-099.4	Overheat Normally Closed	Overheat Normally Open
13-099.5	Viscosity Normally Open	Viscosity Normally Closed
13-099.6	Floor Normally Closed	Floor Normally Open
<b>Flood:</b>		
13-149.0	Car cannot run in normal on Flood	Car can run in normal operation in flood
13-149.1	Fire Overrides Flood	Flood overrides Fire
<b>Sabbath:</b>		
13-093.0	Sabbath Key Not Enabled	Sabbath Key Enabled
13-093.1	Sabbath Timer Not Enable	Sabbath Timer Not Enable
13-093.2	Buzzer Disabled on Close	Buzzer Enabled on Close
13-093.3	Photoeye Enabled on Open	Photoeye Disabled on Open
13-093.4	Car Calls Accepted on Sabbath	Car Calls Rejected on Sabbath
13-093.5	Hall Calls from Group Accepted on Sabbath	Hall Calls from Group Rejected on Sabbath
13-093.6	Photoeye (PHE) Enabled on Close	Photoeye (PHE) Disabled on Close
13-093.7	Car goes from bottom to top floor stopping at all landings in both directions of travel	Car goes from bottom to top floor skipping intermediate floors and then stops at all landings going down
<b>Other:</b>		
00-111.2	Normal Operation	Terminal to Terminal Test runs.
00-111.3	Up and Down Hall Call Button per floor	Single hall call button and in use lamp on every floor
13.149.2	No external key needed of car-top inspection	Requires In car or Access inspection to be turned on to run in car-top inspection.
13-152.3	Pre-flight Check is ON	Pre-Flight Check is OFF (used for troubleshooting only)

## Adjust Parameters

To turn on the options below, go to the MAIN MENU | DEBUG | ADJUST PARAMETERS menu and set any of the following parameters.

*Pressing the enter key once will show a converted hex to decimal number above the hex value, as well as other display options to make it easier to adjust.*

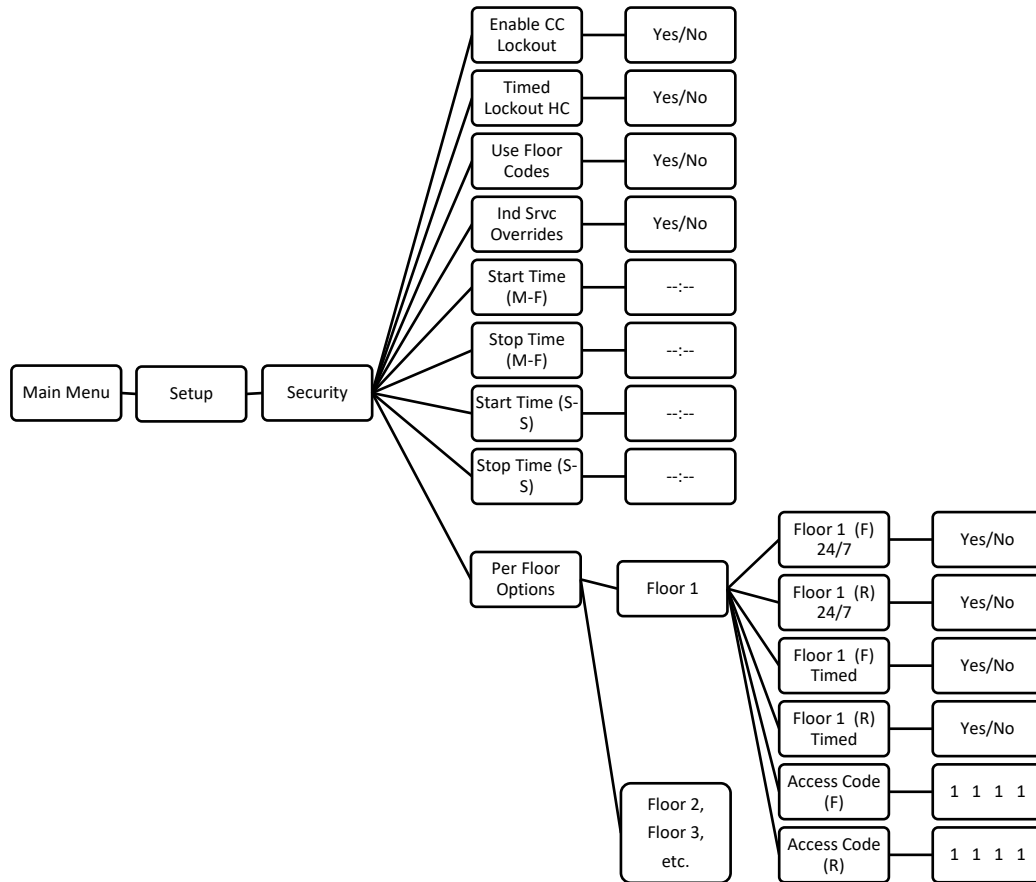
Parameter	Unit (shown in Hex)	Description:
00-025	1 Minute	Screen Saver Lockout timer.
00-041	Faults	Faults allowed Per hour before car going Out of Service
00-042	Starts	Starts per minute allowed before car going Out of Service.
00-046	100ms	Attendant Service Hall Call Buzzer Duration
00-053	1 Second	Door Hold button time
00-083	Base 0 floor	Simplex Parking floor (0 is first landing)
13-127	1 Second	Exit Swing operation timer
13-156	100ms	Wye Delta delay until swapping from S (start) to R (run) contacts.
13-140	0 == closest 1+ == landing	Out of service input, value of 0 will stop at the next available floor, any other value will drive car to that specific landing.
13-160	Voltage at switch	UT1 Trip Threshold
13-161	Voltage at switch	DT1 Trip Threshold
13-177	Voltage at switch	UT2 Trip Threshold
13-178	Voltage at switch	DT2 Trip Threshold
13-179	Voltage at switch	UT3 Trip Threshold
13-180	Voltage at switch	DT3 Trip Threshold
13-181	Voltage at switch	UNTS4 Trip Threshold
13-182	Voltage at switch	DNTS4 Trip Threshold
15-002	Hex Code	Screen saver Lockout code.
13-091	15 min block	Sabbath Start Time
13-092	15 min block	Sabbath Stop Time
13-094	1 second	Sabbath Door Dwell Time – Non-Lobby
13-095	1 second	Sabbath Door Dwell Time – Lobby



# ADDENDUM V – SECURITY

## SECURITY SETUP

- Go to MAIN MENU | SETUP | SECURITY to access the menu items for setting up security. Below is the hierarchy for the Security menu:



- Enable CC Lockout (Yes/No)
  - This item enables / disables the car call security inputs (CCE) on the SRU board and any programmed Access Codes.
- Timed Lockout HC (Yes/No)
  - This enables the hall call buttons to be locked out similar to Enable CC Lockout based on the time set in Start/Stop settings
- Use Floor Codes (Yes/No)
  - This enables the use of an access code (see section 7) to unlock specific floors.
- Independent Service Overrides (Yes/No)
  - Allows putting the car on Independent Service to bypass any active security.
- Start/Stop Time (M-F); Start/Stop Time (S-S)
  - This is where the timed security start and stop time for Monday through Friday (M-F) and Saturday and Sunday (S-S) is inputted. This time is adjustable in 15 minute increments. To lock out a timed 24 hour period set both the Start and Stop times to the same time (i.e. 12:00AM). This is useful for customers with buildings that don't want to allow weekend access but desire timed access during the weekdays.

7. Per Floor Options – Floor # is the floor selected for security options
  - a. Floor # (F)/(R) 24/7 (Yes/No)
    - i. This will activate the specific floor’s security 24hours/day – 7 days/week.
  - b. Floor # (F)/(R) Timed (Yes/No)
    - i. This allows security for the specific floor to be active for a set period of time (see section 6).
  - c. Access Code
    - i. This is a 4 digit code that is programmable based on the car call buttons. For example, a 2-stop car will only be able to use CCB1 & CCB2 for the 4 digit code where a 5-stop can use any combination of the 5 CCB’s for the code.
    - ii. Examples;
      1. 2-stop, Floors G & 1 – Code can be any combination of the 2 car call buttons (for example: “G 1 G 1”).
      2. 5-stop, floors B, L, 1-3 – Code can be any combination of the 5 car call buttons (for example: “L 2 1 B”).

**Programming Example 1: (4-stop, L, 1-3, front opening) – 24/7 lockout with card reader in car**

1. Start by wiring in the CCE inputs on the COP to the card reader – one side of the card reader to 24vdc and the other side to the CCE input.
2. Go to MAIN MENU | SETUP | SECURITY | PER FLOOR OPTIONS | FLOOR # and choose the 2<sup>nd</sup> floor for security (in this case floor 1) “Floor 1 (F) 24/7”, change to “Yes”. Scroll to the right to “Save” and press enter.
3. Go to MAIN MENU | SETUP | SECURITY | ENABLE CC LOCKOUT and change to “Yes”. Scroll to the right to “Save” and press enter.
4. Floor 1 will be locked out until the CCE for floor 1 is activated with card reader.

**Programming Example 2: (4-stop, L, 1-3, front opening) – 24/7 lockout with Access Codes**

1. Go to MAIN MENU | SETUP | SECURITY | PER FLOOR OPTIONS | FLOOR # and choose the 2<sup>nd</sup> floor for security (in this case floor 1) “Floor 1 (F) 24/7” and change it to “Yes”. Scroll to the right to “Save” and press enter.
2. In the Floor # menu choose “Access Code (F)” and change to whatever 4-digit code you want assigned for this floor using the car call buttons. For this example we’ll use “L 2 2 1”. Scroll to the right to “Save” and press enter.

Note: The default code is the bottom landing PI as all 4 digits (In this case: “L L L L”).

\*\* You cannot leave it at the default as this will disable the code. \*\*

3. Select “Enable CC Lockout” change to “Yes”, scroll to “Save” and press enter.

To operate the Access Code feature, press the button for the secured floor. When the button starts flashing, type in the 4-digit code for that floor. The car will latch the car call when the correct code is entered.

*NOTE FOR 2-BOARD SYSTEMS ONLY: If Access Code isn’t working, go to MAIN MENU | DEBUG | ADJUST PARAMETERS and change 00-111 to “x01”. Cycle the main disconnect and retry the security feature.*

## ADDENDUM VI – SCREEN LOCKOUT FEATURE

---

To prevent access to the controller functions there is a screen lockout option available. Parameters 00-025 and 15-002 control this function. The option is disabled at the factory.

Parameter 15-002 = the code you want to program for screen access

Parameter 00-025 = how long to wait (in minutes) after any menu navigation key is pressed before locking the screen.

-----

Example:

You want the screen to lock if no button is pressed for 5 min. Once locked, the user has to enter 1234 to gain access to the controller screens. Set the following parameters:

1. MAIN MENU | DEBUG | ADJUST PARAMETERS | 00-025 = x05
2. MAIN MENU | DEBUG | ADJUST PARAMETERS | 15-002 = x1234

If no key is pressed for 5 minutes (or if the board is reset), the screen will prompt you to "Enter access code". Use the arrow keys to enter the code then press the center (ENTER) button and access will be granted.

-----

If you forget your password, do the following:

1. Put the car on Inspection MR.
2. Turn on DIP switch 1 on Dip A to the right (ON) on the machine room SRU board.
3. Press the reset button. (The screen will unlock for 30 seconds).
4. Set MAIN MENU | DEBUG | ADJUST PARAMETERS | 15-002 = x0000
5. The screen lock option is now off. You can now set it to a new value if you wish or leave it disabled.

## ADDENDUM VII – PI CONVERSION TABLE

The following tables show the PI conversion for the Smartrise SRU board display, the CE Driver board display and the Fixture display.

SRU	CE	Fixture		SRU	CE	Fixture
!				>	>	/
“				?	?	-1
#				@	@	*
\$				A	A	A
%				B	B	B
&				C	C	C
‘				D	D	D
(				E	E	E
)				F	F	F
*				G	G	G
+				H	H	H
,				I	I	I
-				J	J	J
.				K	K	K
/				L	L	L
0	0	0		M	M	M
1	1	1		N	N	N
2	2	2		O	O	O
3	3	3		P	P	P
4	4	4		Q	Q	Q
5	5	5		R	R	R
6	6	6		S	S	S
7	7	7		T	T	T
8	8	8		U	U	U
9	9	9		V	V	V
:	:	*		W	W	W
;				X	X	X
<	<	<		Y	Y	Y
=	=	-		Z	Z	Z

## ADDENDUM VII – PI CONVERSION TABLE – CONT.

The following tables show the PI conversion for the Smartrise SRU board display, the Emotive Driver board display and the Fixture display.

SRU	Emotive	Fixture		SRU	Emotive	Fixture
!				>	⊠	⊠
“				?	▽	▽
#				@		
\$				A	A	A
%				B	B	B
&				C	C	C
‘				D	D	D
(				E	E	E
)				F	F	F
*	*	*		G	G	G
+				H	H	H
,				I	I	I
-	-	-		J	J	J
.				K	K	K
/				L	L	L
0	0	0		M	M	M
1	1	1		N	N	N
2	2	2		O	O	O
3	3	3		P	P	P
4	4	4		Q	Q	Q
5	5	5		R	R	R
6	6	6		S	S	S
7	7	7		T	T	T
8	8	8		U	U	U
9	9	9		V	V	V
:	*	*		W	W	W
;				X	X	X
<	-1	-1		Y	Y	Y
=	-	-		Z	Z	Z